

# Drivers manual

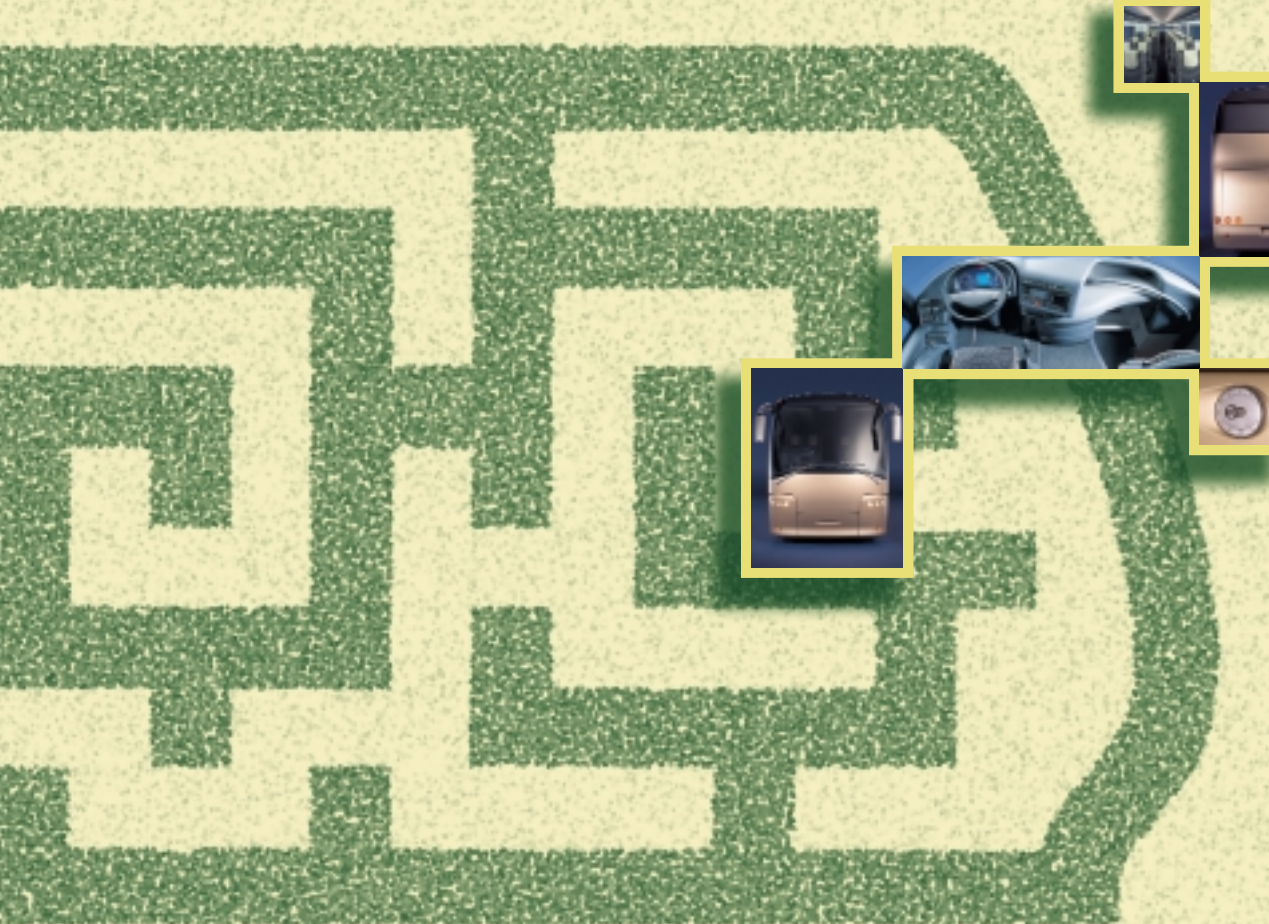

*magiq*



**BOVA**

While this manual has been written with the greatest of care, Autobusfabriek BOVA b.v. can not be held responsible for any deficiencies or the consequences thereof.

The specifications, designs and illustrations in this manual have no binding effect.

We reserve the right to make changes without prior notice.

Nothing in this publication may be copied or made public without prior written permission from BOVA.

**Autobusfabriek BOVA b.v.**  
**Afdeling Service**  
**Postbus 5**  
**5550 AA Valkenswaard (NL)**

Version 2, August 2002  
Order number: B267501GB

*magis*

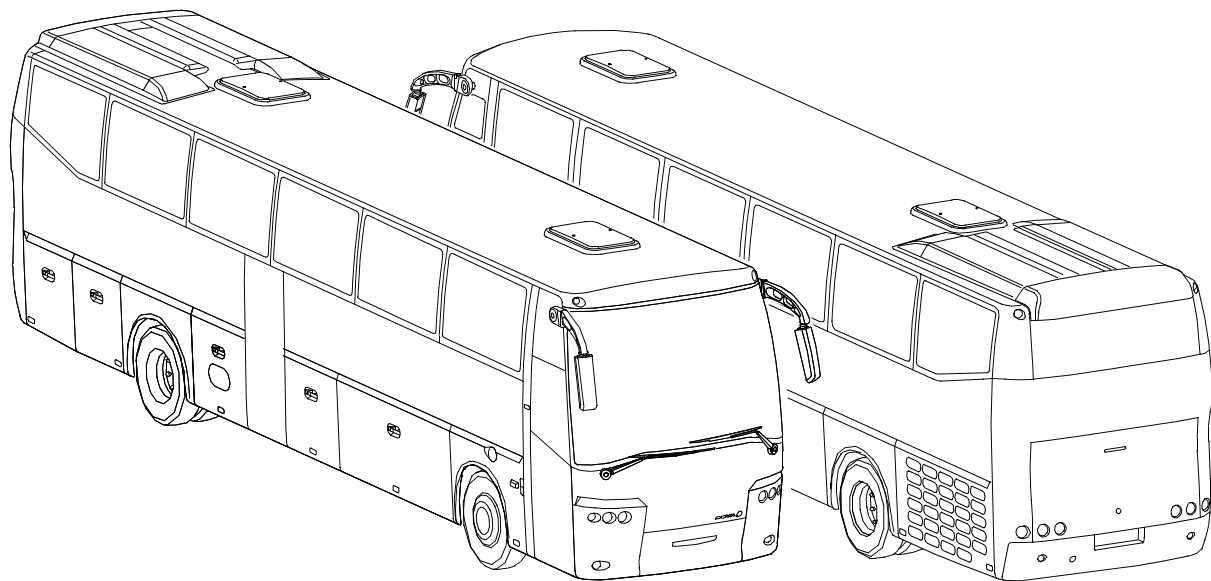

Ch 10320220 ++





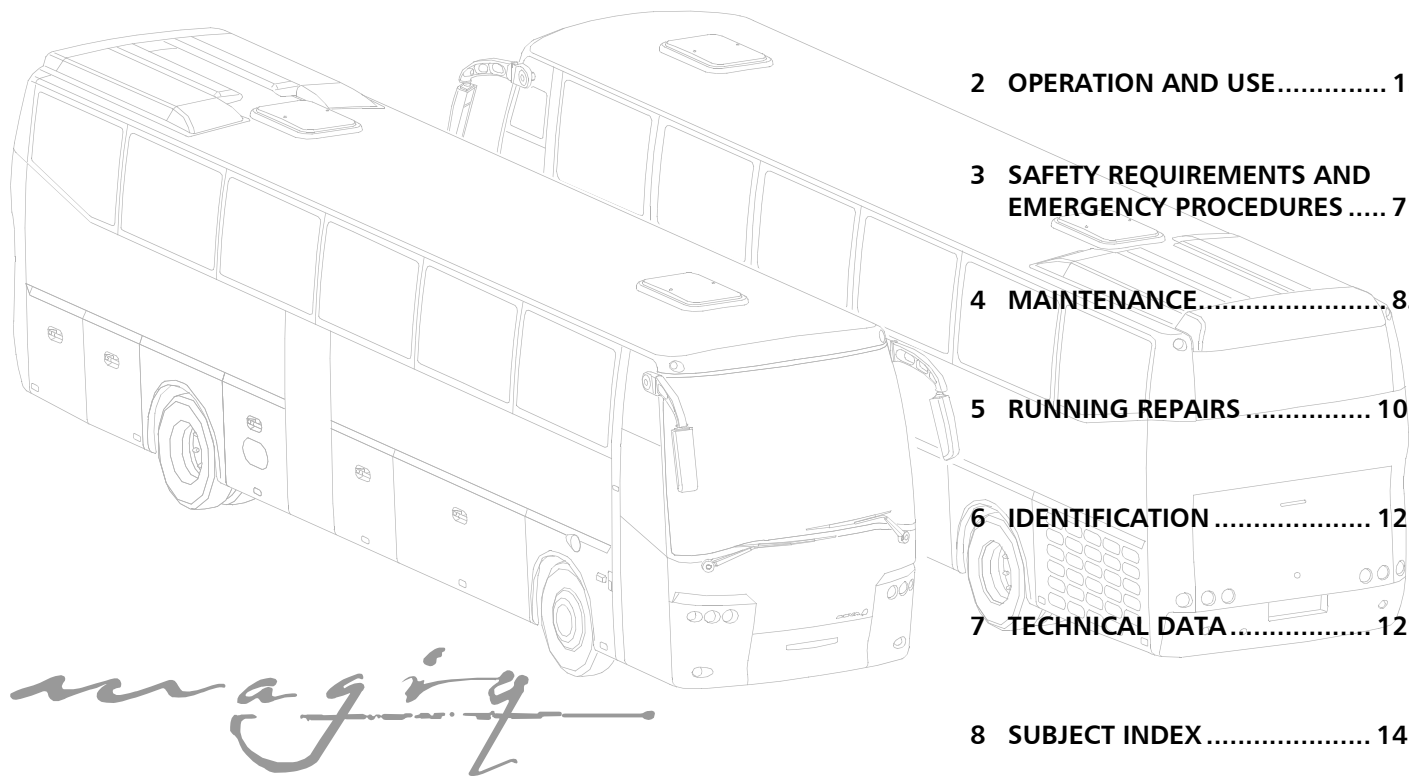

## CONTENTS

1 INTRODUCTION .....	1
2 OPERATION AND USE .....	13
3 SAFETY REQUIREMENTS AND EMERGENCY PROCEDURES .....	75
4 MAINTENANCE .....	83
5 RUNNING REPAIRS .....	101
6 IDENTIFICATION .....	121
7 TECHNICAL DATA .....	129
8 SUBJECT INDEX .....	141



*magiq*



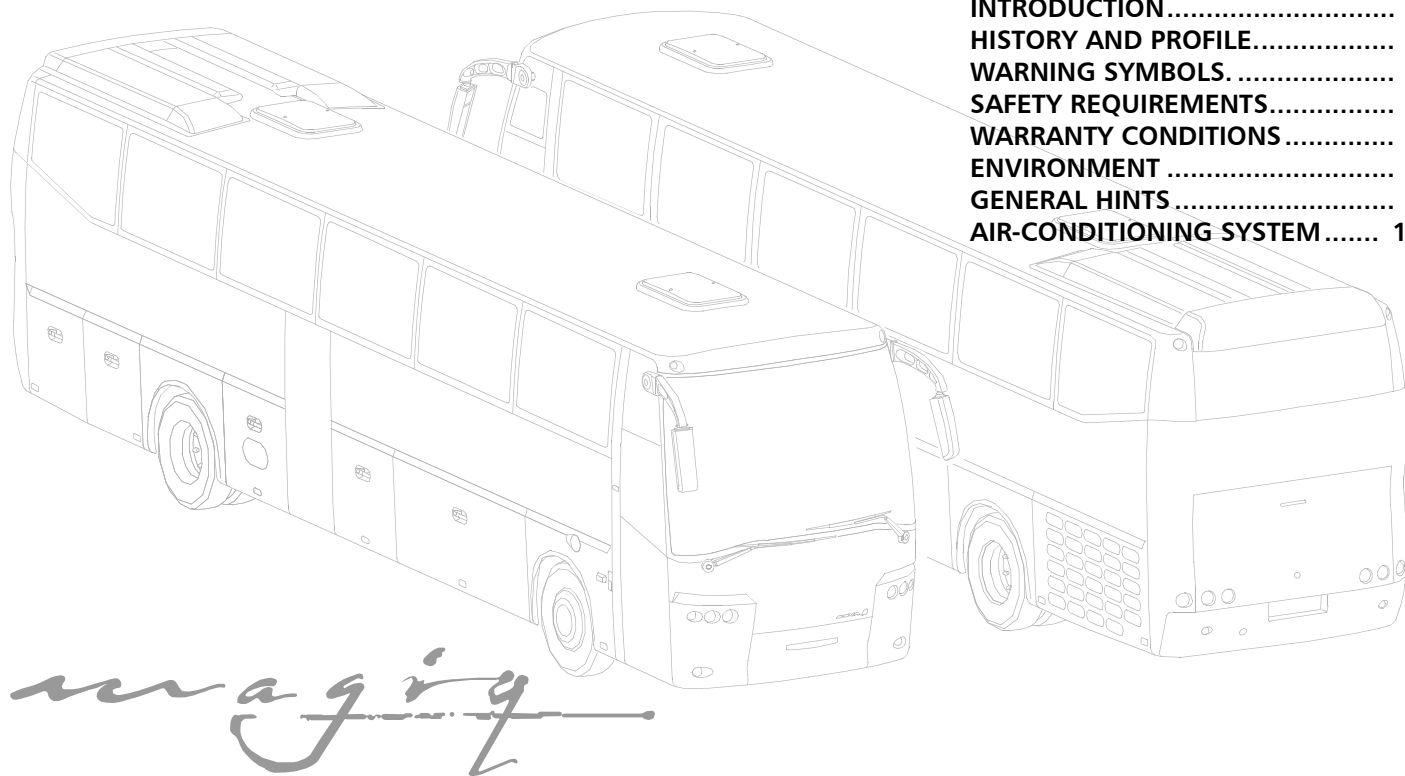

# 1 INTRODUCTION

INTRODUCTION.....	3
HISTORY AND PROFILE.....	4
WARNING SYMBOLS.....	5
SAFETY REQUIREMENTS.....	5
WARRANTY CONDITIONS.....	7
ENVIRONMENT .....	8
GENERAL HINTS.....	8
AIR-CONDITIONING SYSTEM.....	12





## INTRODUCTION

Congratulations on purchasing your BOVA Magiq. You've made a good choice. The BOVA Magiq has outstanding ride quality, performance and reliability, low fuel consumption and an emphasis on safety and comfort.

Reliability, durability, safety and a comfortable ride are the hallmark of **BOVA** products.

A careful reading of this manual before driving the vehicle for the first time will help make the most of these characteristics and fulfill your expectations.

A thorough knowledge of the maintenance instructions will increase driver satisfaction and will above all have a favourable influence on the durability of the vehicle. The capabilities of the vehicle can be fully exploited

### Aim

The aim of this manual is to familiarise the driver or user with the vehicle, so BOVA need to pass on as much information as possible about the use, operation, safety and maintenance of the vehicle.

The manual includes information about standard and optional features.

Alternative equipment, for example manual or automatic transmission, is discussed.

This means that you may skip certain sections in the manual which deal with equipment not fitted to your vehicle.

### Layout

The layout of the manual is designed to be practical and to provide an overview.

There are 8 chapters in the manual. Each chapter is numbered and is easy to locate using dark markings in the margins.

Each chapter begins with a detailed contents section which will help you find your way around the relevant chapter.



**An index at the end of the manual will enable speedy location of topics.**



**Make sure this manual is always in the vehicle and read through it carefully before first driving it.**



## HISTORY AND PROFILE.

Jacob Bots started out as a timber merchant in Valkenswaard in 1878. His son Simon introduced the name **BOVA** in 1910: it comes from **BO**ts **V**alkenswaard.



Our logo refers to this history, with the B from Bots and the falcon (valk) as symbol of Valkenswaard, which was renowned from ancient times as a centre of falconry.

Since 1931 BOVA's core activity has been the development, production, sale and service of luxury coaches. BOVA have been building integral coaches for more than 30 years and have built up extensive experience in this advanced construction method for coaches.

BOVA try always to develop lasting relationships with our business partners, on a basis of trust: clients are central to this.

We put a lot of effort into helping them optimise the return on their investment.

This calls for: minimal costs per mile, the highest possible quality standards, maximum comfort and optimal safety for passengers and drivers.

BOVA can rely on a well-trained and highly motivated workforce, both at our Valkenswaard headquarters and abroad.

Our organisation is flexible, but continues to search for ways to broaden this flexibility. Our sales division have premises in the Benelux countries, Germany, France, Switzerland, Italy, Spain, Poland and Denmark. We have a branch in Sweden and importers in Great Britain, Czechoslovakia and elsewhere.

BOVA ensures the continuity of the business by using all means at our disposal to produce the finest products. Production processes, development, logistics, quality assurance, marketing and service are continually monitored and optimised, to ensure that everyone concerned has the most up to date methods and tools at their disposal. This serves to further the interests of the customer, as well as our workforce, suppliers and shareholders.

## WARNING SYMBOLS.

You will find the following symbols in your manual.

Take note of the tip or warning accompanying the symbol!



**This symbol gives useful tips to simplify operations.**



**This symbol indicates that extra care is required.**



**This symbol indicates a situation which might result in damage to the vehicle.**



**This symbol indicates a situation which might result in personal injury.**

## SAFETY REQUIREMENTS

Strict adherence to the following safety requirements is necessary to prevent risk to your own or others health and safety.

### Warnings and safety instructions.

Always read the instructions and warnings on labels and stickers. Don't ignore them, they are there to ensure your safety and health!

### Engine

Do not allow the engine to run in a closed or unventilated space.

### Engine compartment

Keep away from moving parts.

### Warning triangle

Always have a warning triangle available (it is a legal requirement in some countries) supplemented as necessary with other means of marking.

## Winter conditions

Whenever severe winter conditions are expected make sure to fit winter tyres and carry snow-chains. See also: Wheels and tyres page 131.

### Luggage

All luggage must be stowed so that it cannot shift or fly loose, even in an emergency stop. Bear in mind that the ride characteristics of a fully loaded vehicle differ from those of an empty vehicle.

### Fluids and greases.

Various fluids and greases may damage the health through skin contact, ingestion or inhalation, so avoid physical contact wherever possible.

Spilled fluids may react aggressively with other materials, so clear them up as quickly as possible.

To prevent risk of fire the engine and its surroundings must be kept free of (highly) flammable materials.



## Welding

When welding on the vehicle first the negative and then the positive cable should be disconnected from the batteries.

Disconnect the alternators.

Place the earth clamp of the welding apparatus as close as possible to the welding location and ensure a good contact with the item being welded. Do not connect the earth clamp to the axles.

Take care that welding spatter does not land on plastic fuel pipes or on air lines or similar.

## Batteries



**Never disconnect battery cables while the engine is running!**

Always disconnect the battery earth cable when working on the electrical system.

Never place tools on a battery, they can cause short circuits and in the worst case the battery may explode.

## Battery charging

During battery charging, provide good ventilation and avoid sparks and open flames.



**Allow frozen batteries to thaw, and remove all filler caps before charging.**

Connect the positive (+) lead from the battery charger to the positive (+) battery terminal first, and then connect the negative (-) lead to the negative (-) terminal.

When charging is complete switch off the charging apparatus and then disconnect first the negative (-) and then the positive (+) lead.

For "normal charging" the battery cables may remain connected.

Use a high speed charger only in case of extreme urgency.



**Both battery cables must be disconnected when carrying out high speed charging to avoid damage to vehicle electronics.**



**Do not use a speed starter set to start the vehicle as this may damage the vehicle electronics.**

## System voltage

The vehicle is provided with a 24 volt electrical system.

When replacing or upgrading electrical or electronic components, ensure that these are suitable for this voltage.

## Mobile telephones and Transmitters

The following precautions relate to the use of mobile phones and transmitters.

- Mobile phones and transmitters must not be used in the vehicle except via a separate external aerial.



**The use of mobile phones or transmitters without a separate external aerial may cause excessive electromagnetic fields (the resonance effect) within the vehicle. It is possible that this may lead to**

disturbances to the vehicle electronics.

- In addition, the optimum range of this equipment can only be achieved with the use of an external aerial.



**Always follow the operating instructions for mobile telephones and transmitters.**

### **Original BOVA parts.**

Do not modify your vehicle with non-original BOVA parts.

Bear in mind that any modification to your BOVA vehicle with non-original parts may adversely affect its performance, safety, durability and the guarantee.

Modifications may also conflict with legal requirements.

## **WARRANTY CONDITIONS**

The BOVA warranty covers faults in materials, construction and fitting, for new coaches, with normal use and maintenance, for a period of 12<sup>1</sup> months from the date of delivery of the vehicle, or from first registration.

For further details see BOVA's general warranty conditions.

---

1. An optional extended warranty is available.



## ENVIRONMENT

To prevent unnecessary damage to the environment, you should observe the following guidelines:

- Waste fluids should be carefully collected and segregated, and should then be delivered to an authorised site for recycling or disposal.
- Improper disposal of fluids may be a criminal offence.
- Ensure that the vehicle is regularly maintained. A properly maintained vehicle uses fuel more efficiently and emits less harmful exhaust gases.
- Don't allow the engine to run unnecessarily when stationary, and always drive using the appropriate engine speed.

## GENERAL HINTS

Take note of the following recommendations before using the vehicle in traffic.



**The roof hatches should be unlocked before the journey commences.**

### Filling fuel tanks

Use only diesel fuel of satisfactory quality.

Make sure that the filler cap and the area around it are free from dust, and avoid mixing water with the fuel during filling.



**To prevent water condensation, avoid allowing the level of fuel in the tank to fall unnecessarily low.**

### Running in

It is advisable to avoid high performance of the vehicle during the running-in period.

This also applies when a reconditioned engine, gearbox or differential has been fitted.

For the first 1500 km you should therefore:

- Avoid driving under full load.
- Change down in good time: a relatively high engine speed is less harmful than overloading the engine with excussively low engine speeds.
- Do not drive with a trailer attached.



**Following a cold start, use a moderate engine speed and avoid heavy acceleration until the coolant temperature reaches 50 °C.**

Keep a regular eye on the instrument panel while driving and respond alertly when irregularities are observed.

## Wheel nuts.

The wheel nuts must be retightened (615 Nm) when 100 km have been travelled following delivery of the vehicle.

The wheel nut torque must be checked again after a further 500 km.

## Fuel economy

Driving economically isn't simply driving slowly, it requires anticipation and a fluid style, and adapting the driving style to the existing conditions.

Keep in mind:

- Warm up the engine as quickly as possible by driving off as soon as possible under moderate load.
- Drive smoothly, avoiding unnecessary acceleration and harsh braking.
- Change gear in good time and keep the engine speed in the optimal (green) range.

The most significant factor in fuel consumption is the driver himself and how he uses the accelerator pedal, the brake pedal and the gear lever.

## Starting procedure



**The engine can not be started with the bonnet open.**

Turn on via the masterswitch. Depress the clutch pedal (not applicable to vehicles with automatic gearbox) and select neutral gear. The automatic preglow system operates if the temperature is low. The electronic unit determines the necessary preglow and afterglow periods. The necessary glow time depends on the temperature measured by the engine management system.

## Switch on the ignition.



**When the engine starts, the engine speed should not be increased until the oil pressure lamp is extinguished.**

## Clutch

Wear on the clutch depends to a great extent on the driver.

To reduce clutch wear to a minimum, follow these guidelines:

- On moving off, always select first gear and where possible a low engine speed.
- On accelerating after a gear change, give gas only after the clutch is fully engaged.
- Avoid riding the clutch.
- Avoid unnecessary acceleration in traffic queues.
- Use the brakes to stop.



## Braking

The vehicle is equipped with an ABS braking system.

The ABS braking system prevents the wheels locking during braking on slippery road surfaces or in an emergency stop.

The ABS system only switches in at maximum braking, at the moment when one or more wheels lock and the vehicle threatens to skid.

At that instant the ABS system allows the brake pressure to fall until the wheel begins to rotate and grip on the road surface is restored. The braking force is then immediately increased until maximum braking is achieved, or until the wheel in question locks up and the cycle is repeated.

The vehicle thereby remains fully steerable in such conditions and a stable course is maintained.



**Don't adapt your driving and braking to the ABS system.**

In particular, don't brake later and harder, as this wears the tyres and may cause difficulties for other road users.



**Braking distances with ABS are sometimes, but not always shorter.**

On starting, the ABS signal lamp will be illuminated while the system checks are performed. The lamp should go out after a few seconds. If the lamp remains on, or comes on during a journey, there is a fault in the ABS system.

Normal braking function will be maintained but there is a possibility of the wheels locking during heavy braking.

The ABS system must now be tested in a workshop.

## Stopping

Bring the vehicle to a halt.

Select neutral gear.

Allow the clutch pedal to rise (not applicable to vehicles with automatic gearbox).

## Parking

Stop the vehicle.

Operate the parking brake by means of the brake lever.

When parking on an incline the following should be considered:

- Place chocks in front of or behind the wheels.
- Turn the front wheels so that the vehicle will not head out into the thoroughfare if it should move for any reason.

Switch off the ignition and master switches.

## Switching off engine



**After a long journey or when it has been put under heavy load, allow the engine to idle while stationary for a while before switching off.**

Park the vehicle.

Stop the engine by first switching off the ignition.

Then turn off the master switch.

## Air leaks.

A rapidly falling air pressure reading with a stationary engine indicates a leak.

The leak must be repaired without delay as the safety of the braking system is impaired.

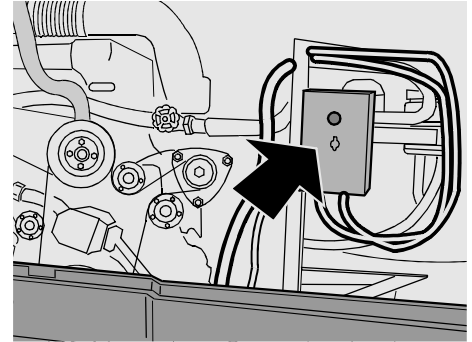

50031A

## Engine stop button in the engine compartment.

The engine can if necessary be stopped using the button in the engine compartment.



**Remember to reset the stop button before closing the engine compartment.**

## Speed limiting device

The speed limiting device on your vehicle is set at 100km/h.

## AIR-CONDITIONING SYSTEM

On 1 January 1993 the Substances affecting the ozone layer law came into force in the Netherlands. The purpose of this law is, among other things, to drastically reduce coolant emissions from cooling installations. The following measures accordingly apply:

- The use of CFC's in new installations is forbidden
- Technical requirements are made of technical cooling installations
- Work on cooling installations may only be done by qualified personnel.
- The responsibilities of the owner/operator of the installation are being increased. Implementation is by means of a logbook and maintenance obligation.

The intended reduction in emissions can only be effective with the registration of the use of coolants and their control.

## STEK (only the Netherlands)

For cooling installations in Dutch coaches registration must take place with the use of a logbook. Also, periodic maintenance for such installations is compulsory. Registration of this must also take place in the logbook.

Both obligations apply for existing and new installations. Control is carried out by inspectors from STEK by order of the Ministry of Housing and the Environment.

A CFC logbook has been introduced to simplify the control of technical cooling installations. This logbook complies with the instructions issued by the STEK and is supplied with each BOVA coach. The logbook must also be presented each time there are repairs and/or a change to the system.

# 2 CONTROLS AND OPERATION

- DOORS ..... 15
- INSTRUMENTS AND CONTROLS . 19
- MESSAGES ON THE DISPLAY..... 47
- DISPLAY..... 51
- PASSENGERS' AREA ..... 66
- DRIVER'S SLEEPING COMPARTMENT..... 68
- TOILET..... 70
- KITCHEN..... 71
- NAVIGATION SYSTEM..... 71
- AIR SUSPENSION (ECAS)..... 71
- STEERING GEAR..... 72
- MIRRORS ..... 73



*magiq*



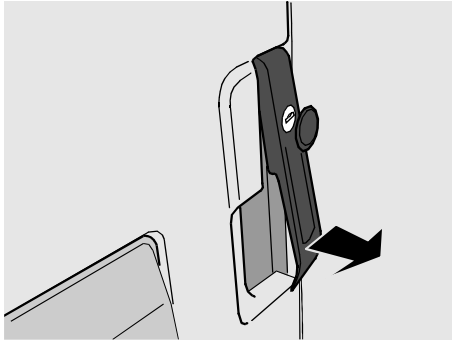

20010A

## DOORS

### Passenger door/Central door

The passenger door may be unlocked with a key, after which the handle must be pulled out a little, which causes an air valve to be operated electrically, opening the door. A contact strip on the edge of the door prevents trapping when the door closes. The central door is opened in the same way.

The central door can only be opened if the hatch to the driver's sleeping compartment is closed.

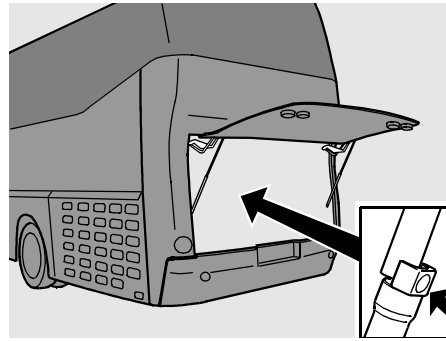

10002A

## Bonnet



**When the bonnet is open, avoid contact with hot or moving parts.**

The bonnet is opened by undoing the lock with the key and pulling at the same time on the bonnet. The bonnet hinges upwards with the aid of 2 gas springs.

When the bonnet is raised the left hand gas spring is mechanically locked.



**Release the lock before closing the bonnet.**

The lock is released by pushing the spacer cover against the spring, allowing the bonnet to be closed.



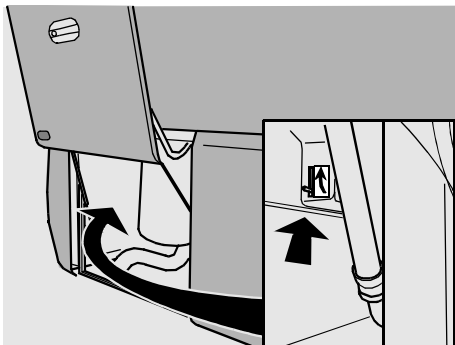

10024A

If the key breaks off in the lock the bonnet can also be opened by pushing up the red lever.



**The bonnet can only be opened with this lever when the broken key is still in the lock.**

### Luggage doors

The luggage compartments can be unlocked using the switches on the dashboard. Where there is no electrical power available, the compartments can only be opened from inside, by giving the knob a quarter turn to the right. See: Luggage flaps. page 79.

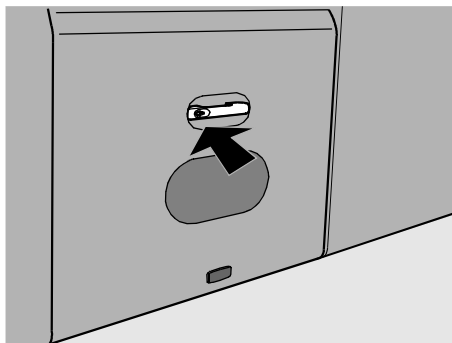

20014A

### Driver's sleeping compartment hatch

The driver's sleeping compartment hatch can be unlocked with a key and the flap can then be opened. Engine compartment side flap. The engine compartment side flap may be unlocked with a key and the flap can then be opened.

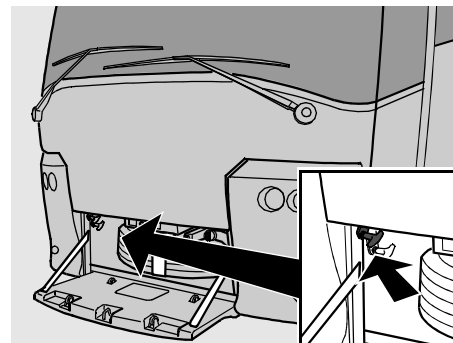

10023A

### Battery compartment

The battery compartment can be unlocked by pulling the handle behind the spoiler flap, whereupon the flap can be opened

### Engine compartment side flap.

The engine compartment side flap may be unlocked with a key and the flap can then be opened.



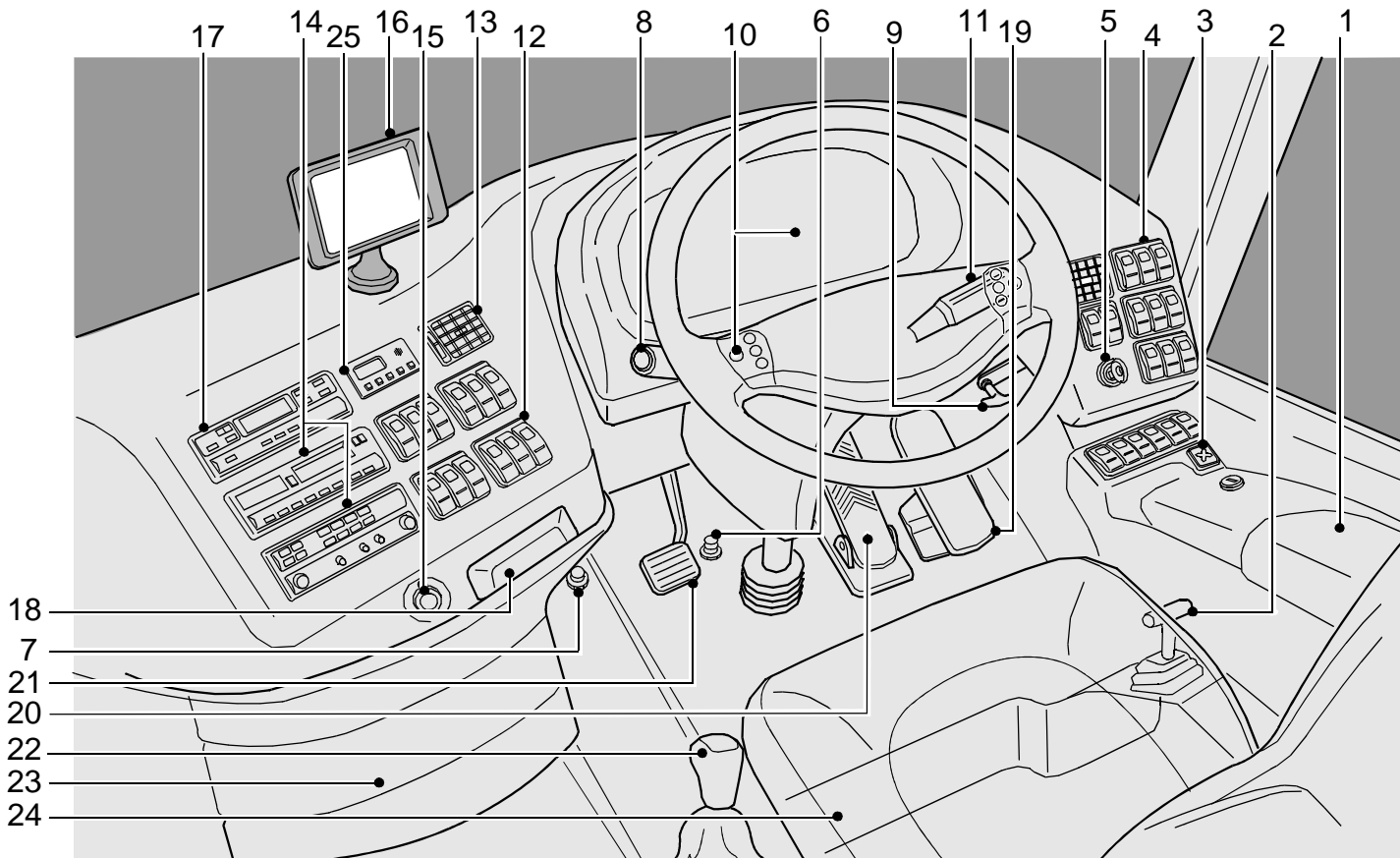

## INSTRUMENTS AND CONTROLS

1	Driver's locker	19
2	Parking brake.	19
3	Mirror adjustments	19
4	Right hand dashboard switches	20
5	Ignition switch	23
6	Steering adjustments	23
7	Engine brake	24
8	Left combi-switch	25
9	Spoiler flap handle	26
10	Instrument panel	26
11	Right hand combi-switch	29
12	Central dashboard switches	31
13	Ventilation grills	32
14	Audio	32
15	Cigar lighter	32
16	Navigation system	33
17	Tachograph	33
18	Ashtray	39
19	Accelerator pedal	39
20	Brake pedal	39
21	Clutch pedal	39
22	Gear shifting	39
23	Refrigerator	41
24	Driver's seat.	42
25	Standby heater timer	43

### 1 DRIVER'S LOCKER

The storage space on the driver's right is lockable and the upper section can be folded away.

The storage space has dimensions 50 x 40 x 10 cm, to fit an attache case.

The upper section includes a flap for the storage of pens and the like.

The microphone for communication with the driver's sleeping compartment is located behind the driver's seat.

For operation of the communication handset see: Intercom Installation page 69.

### 2 PARKING BRAKE.

The parking brake operates only on the rear axle and is operated by moving the lever to the rear.

When the parking brake is applied a lamp is illuminated on the instrument panel.



The parking brake is released by moving the lever forwards.

Where air pressure is insufficient the ECAS symbol on the display will be illuminated and the parking brake will not release.

It is necessary to wait for the compressor to charge up the air supply

before driving away see: Vehicle information page 57.

If the foot brake is inoperable due to a fault the parking brake may also function as an emergency brake. The vehicle may be brought to a controlled stop by gradually raising the parking brake lever until it reaches its stop.

### 3 MIRROR ADJUSTMENTS

The mirrors are adjustable electrically, provided the main switch and ignition are switched on, by moving the knob up, down, left or right.



Turning the knob to the right = adjust right mirror.

Turning the knob to the left = adjust left mirror.

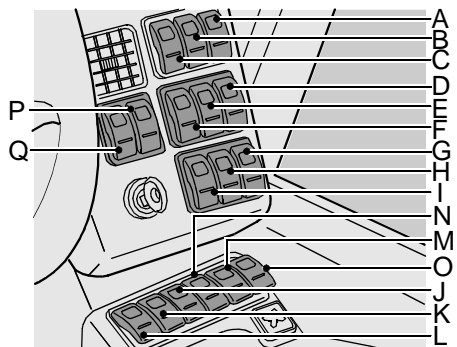

30002A

#### 4 RIGHT HAND DASHBOARD SWITCHES

A	Parking/dipped lights	20
B	Front fog lamp	20
C	Rear fog lamp	20
D	Passenger's reading lamps	20
E	Nightlights	20
F	Interior lights	21
G	Emergency switch (depending on local regulations)	21
H	Option	21
I	Master switch	21
J	Right hand roller shutter	21
K	Left hand roller shutter	21
L	Electrically operated driver's screen	21
M	Raising/kneeling, front	22
N	Raising and kneeling, rear	22
O	Option	22

P	Open/close passenger door	22
Q	Open/ close central door	22

#### A Parking/dipped lights

The switch has three positions.

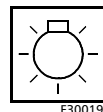

F30019

- 0: All lights off.
- 1: Parking lights on.
- 2: Parking lights and dipped/main beam on (depending on the position of the steering column switch).

The full length of the aisle floor will also be illuminated with LEDs.

This illumination can be switched off using the display, see: Vehicle functions page 58. Dipped or main beam operates only with the main switch and ignition on.

#### B Front fog lamp

Front fog lamps can be switched on if parking, dipped or main beam are on.

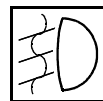

30009A

#### C Rear fog lamp

The rear fog lamp may only be switched on along with the dipped beam or front foglamp or a combination of the two. Switching off the parking lights switches off the rear fog lamp, and the switch must be reset before the rear foglamp can be switched on again.

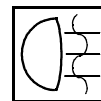

30010A

#### D Passenger's reading lamps

The reading lamps above the passenger's head can only be used when the driver makes it possible using the above switch. The driver can also use this switch to extinguish all reading lamps simultaneously.



30011A

#### E Nightlights

Switches on the blue nightlights above the aisles.

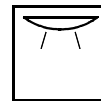

30012A

## F Interior lights

The switch has three positions.

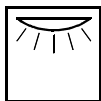

30013A

- 0: Interior lighting off
- 1: Strip lights on
- 2: Strip lights and all reading lamps on



**It is advisable not to leave the interior lighting on for more than 10 minutes with the engine stopped, because of high current consumption.**

## G Emergency switch (depending on local regulations)

In case of emergency all electrical consumers will go off, with the exception of warning lights, standby heating and the tachograph (if applicable in the location).

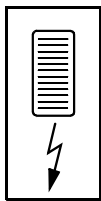

30014A

## H Option

This position is not in use and can therefore be used to operate an optional instrument or accessory.

## I Master switch

When it is switched on the master switch connects the battery with:

- the switches to operate the doors.
- the ignition switch
- audio installation and other accessories, such as video, lighting in the toilet etc.

When the masterswitch is off the tachograph clock continues to run, the warning system may be used and the pre-heater can be activated if previously set.



**The master switch can not be turned off when the engine is running.**

## J Right hand roller shutter

To open or close the right hand roller shutter, push the upper or lower part of this switch respectively.

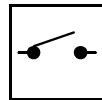

30016A

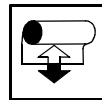

30017A

## K Left hand roller shutter

To open or close the left hand roller shutter, push respectively the upper or lower part of this switch respectively.

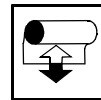

30017A

## L Electrically operated driver's screen

To open or close the driver's screen the switch must be pressed on the top or the bottom side.

If an electrical fault should affect the operating mechanism of the driver's screen, it may be raised or lowered by hand.

The method is as follows:

- Open the battery compartment on the right front of the vehicle.
- Place the window handle (stand-ard on-board equipment) on the mechanism.

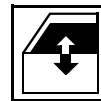

30018A

### M Raising and kneeling, rear

For operation see raising/kneeling, front.

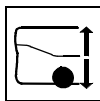

### N Raising/kneeling, front

There are two ways of temporarily changing the coach level by air suspension, making it either higher or lower than the neutral driving level. The temporary high adjustment is usually used to obtain more ground clearance for, e.g. boarding ferries. Adjusting downwards makes it easier for passengers to board.

If the air suspension is not in the neutral position this is indicated in both cases by the illumination of the yellow ECAS symbol in the display. If the air suspension is not in the neutral position the warning light on the switch is illuminated.

- 0: Raising (front and rear)
- 1: Driving position (neutral)
- 2: kneel (front)



If the vehicle is not in the neutral position, the maxi-

mum vehicle speed may not exceed 10 km/h.



The ECAS system switches automatically to driving (neutral) position above 20 km/h, and switches in again if the speed falls below 10 km/h

### O Option

This position is not in use and can therefore be used to operate an optional instrument or accessory.

### P Open/close passenger door

Operation of this switch opens the passenger door and illuminates the red lamp in the switch. Operating the switch again closes the door.

The door is provided with a safety feature so that it immediately re-opens when the contact strip meets an obstruction during closing.

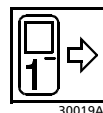

### Q Open/ close central door

Operation of this switch opens the central door and illuminates the red lamp in the switch. Operating the switch again closes the door. The door is provided with a safety feature so that it immediately re-opens when the contact strip meets an obstruction during closing.



The central door will not operate if the driver's sleeping compartment hatch to the side of the central door is not properly closed.

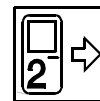

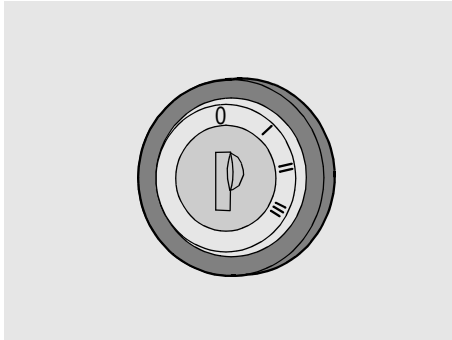

30006A

## 5 IGNITION SWITCH

The ignition switch has four positions which, once the masterswitch is engaged, can be used as follows:

### 0: Neutral position

The key can be removed. All electric consumers which may be needed during a journey are now switched off.

### I: Position 1

The key can not be removed. All electric consumers which may be needed during a journey are now switched on.

All instrument indicator lamps are illuminated for 3 seconds for control purposes, and then only those that are active remain illuminated. The fuel gauge and coolant temperature indicators go to maximum and then return to show the current reading.

Switching to position 1 while the main menu is displayed switches to the driving menu.

Preglow and automatic afterglow will be employed where appropriate. The glow signal lamp in the display will also illuminate. Starting may take place when the glow signal lamp extinguishes.

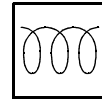

F3002B

### II: Not in use

### III: Starting

Operates the starter motor. The key must be turned further to the right against the spring pressure.



The engine cannot be started if the engine compartment door is open.

## 6 STEERING ADJUSTMENTS

The steering wheel and steering column may be placed in the desired position by operation of the knob. The complete instrument panel is also adjusted along with the steering column, allowing an optimal view of the various meters and indicator lamps. The steering column is locked when the pressure switch is released.



The steering wheel may only be adjusted when the vehicle is stationary.

## 7 ENGINE BRAKE

The engine brake may be used during prolonged braking, for example during descents or when braking from high speeds.

Depressing the engine brake operating knob provides extra braking via the engine. Fuel injection is reduced and the butterfly valve in the exhaust system is closed.

This reduces brake wear.

The additional power declines as the engine speed falls.



**The engine brake does not function at engine speeds below 700 rpm.**

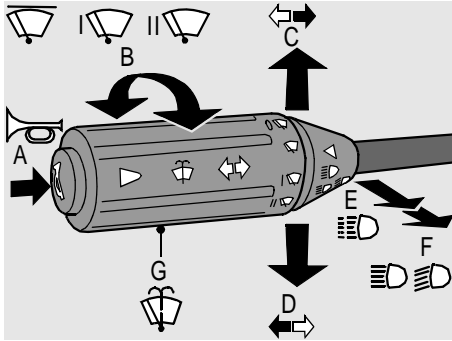

30003A

## 8 LEFT COMBI-SWITCH

### A Air horn

The air horn operates when knob A is pushed in.

### B Windscreen wipers

The windscreen wipers are operated by turning switch B. The switch has 4 positions.

**Position** Wipers off

0:

**Intermittent wipers** In this position the wipers operate every 8 seconds.

**Position** Low wiper speed

I:

**Position** Low wiper speed

II:

### C Direction indicator, right

Moving the switch upwards operates the right indicator. The green indicator lamp in the instrument also flashes.

### D Direction indicator, left

Moving the switch downwards operates the left indicator. The green indicator lamp in the instrument also flashes.

For a brief use of the indicators the switch should be pushed slightly against the spring pressure.

### E Flash main beam

To flash the main headlamp, the switch should be moved to the rear until it meets a resistance.

### F Main beam

Dim or main beam operates if the switch is pulled back past the resistance, but only if ignition is on and switch 4A is fully pushed in. The blue indicator lamp in the instrument illuminates when main beam is on.

### G Windscreen washers

If part G of the switch is pushed in, the windscreen washers operate and the windscreen wipers operate twice.

### Head lamp washers

The headlamp washers operate at the same time as the windscreen washers, when dipped beam is on.

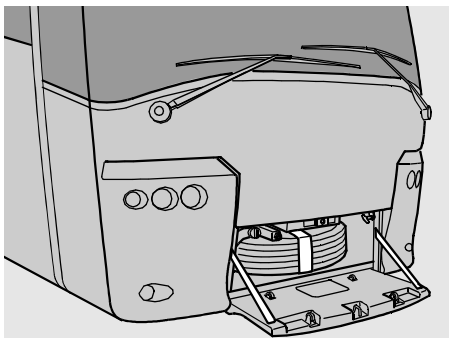

10001A

## 9 SPOILER FLAP HANDLE

The spoiler flap is unlocked by pulling on this handle.

The flap is retained by a catch.

Removing this catch allows the flap to be fully swung down.

The spare wheel, towing eye attachment and screenwash reservoir are located behind the spoiler flap.



**The spoiler flap handle may not be operated during a journey.**

## 10 INSTRUMENT PANEL

A	Speedometer	26
B	Odometer	26
C	Tachograph warning lamp.	26
D	ABS warning lamp	26
E	Main beam indicator lamp	26
F	Indicator warning lamp (green)	28
G	Priority warning 1	28
H	Priority warning 2	28
I	Trailer indicator warning lamps	28
J	Retarder warning lamp	28
K	Parking brake warning light	28
L	Revolution counter	28
M	Clock/tripmeter	28
N	Fuel gauge	28
O	Switching between clock and tripmeter	28
P	Display	29
Q	Brightness adjustment	29
R	Coolant temperature	29

### General

If the ignition is switched on while the master switch is on, all indicator lamps will light up for 3 seconds, with those that are active remaining on.

The fuel gauge and coolant temperature indicators go to maximum and then return to show the current reading.

### A Speedometer

The speedometer inner ring gives the speed in mph, the outer ring shows km/h.

### B Odometer

The odometer records the distance travelled.

### C Tachograph warning lamp.

This lamp is illuminated when there is a fault in the tachograph, or when other problems occur, such as the absence of a tachograph disk.

### D ABS warning lamp

This lamp lights up when the master switch and ignition are switched on. It is extinguished after a few seconds. If the lamp stays on, or comes on during a journey, there is a problem in the ABS system. See also: ABS system page 109.

Normal braking function is maintained, but there is now a possibility of the wheels locking during powerful braking.

The ABS must now be tested in a workshop.

### E Main beam indicator lamp

When the main beam is on, the blue

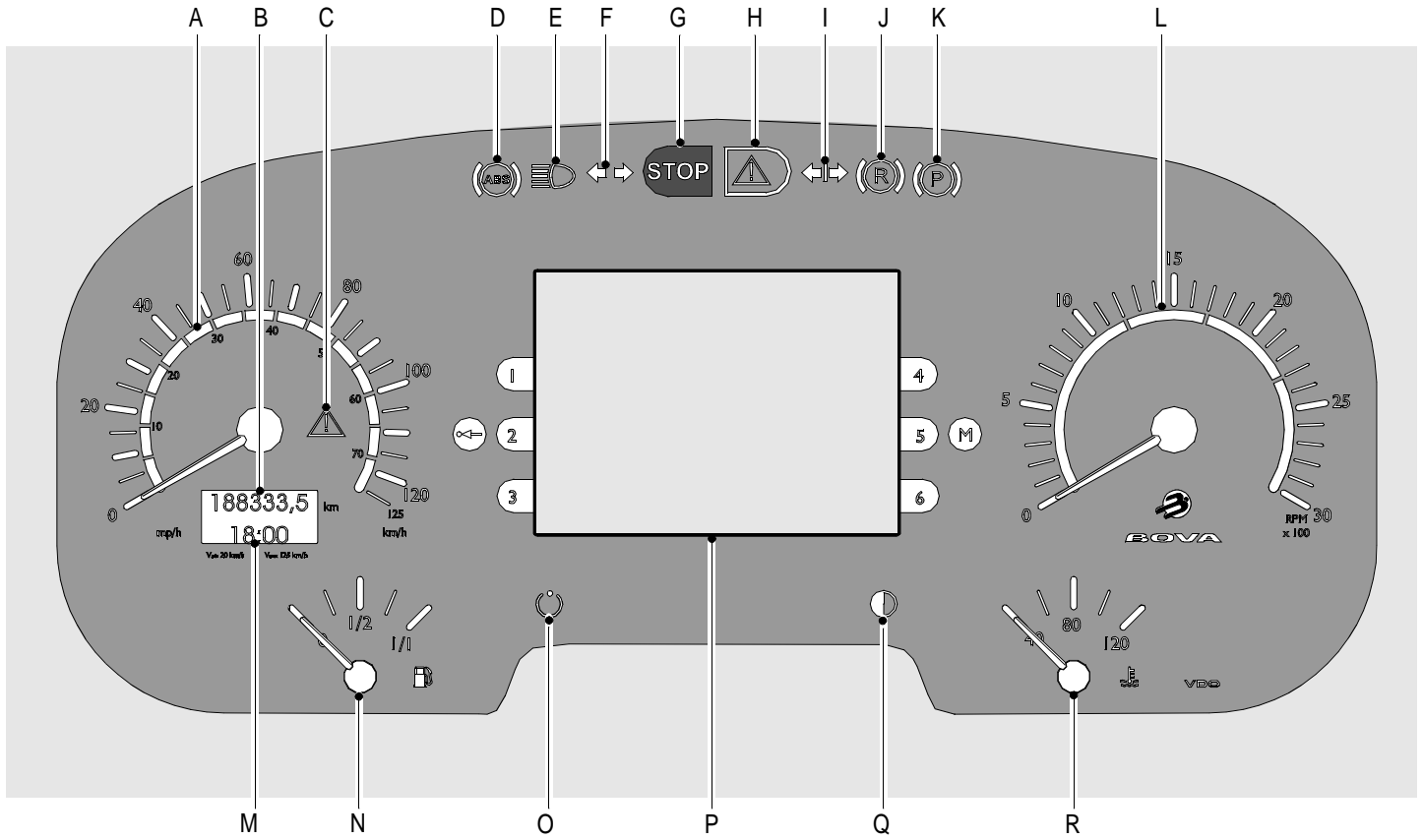

indicator lamp is illuminated. Selection between main and dipped beam is via the left hand combi-switch on the steering column.

#### **F Indicator warning lamp (green)**

When the left or right indicators or the hazard warning lights are switched on, the indicator warning lamps flash with the same frequency. If one of the external indicator lamps fails to flash, the warning lamp flashes at twice the speed.

#### **G Priority warning 1**

If this warning lamp comes on in combination with a fault symbol on the display, the vehicle must be brought to a halt as quickly as possible and the engine stopped, see: Messages on the display page 47.

#### **H Priority warning 2**

If this warning lamp comes on in combination with a fault symbol on the display, there is a problem that must be solved as soon as possible, but the vehicle may be driven to the next available stopping place, see: Messages on the display page 47.

#### **I Trailer indicator warning lamps**

These lamps operate when the indica-

tor lamps are switched on and a trailer is in use.

#### **J Retarder warning lamp**

This lamp lights up when the retarder operates. The brake lights also operate.

#### **K Parking brake warning light**

When the parking brake is operated the warning lamp will come on and the rear wheels will be locked.

#### **L Revolution counter**

The revolution counter has 4 regions:

left hand area:	Very economical
Green:	Economical
Middle area:	Less economical
Red:	Avoid

#### **M Clock/tripmeter**

The clock shows the time and can be set by setting the tachograph clock. Pushing knob (O) switches to tripmeter allowing distance travelled to be measured.

#### **N Fuel gauge**

The fuel gauge operates only when the ignition is on, and shows the fuel level in both tanks. A warning symbol is illuminated in the display when the fuel in the tanks falls below the reserve level.



**There are now around 40 litres of fuel remaining.**

#### **O Switching between clock and tripmeter**

Switching between clock and tripmeter. The trip meter can be reset to zero by pushing the knob in longer.

## P Display

The display normally shows the menu, the outside temperature and the channel selection for driver and passengers. For description see: Display page 51.

## Q Brightness adjustment

The brightness of the display can be adjusted to personal preference.

## R Coolant temperature

The operating temperature of the coolant must be between 87 °C and 99 °C.

Do not over exert the engine when the coolant temperature is below 50 °C.

The warning symbol in the display is illuminated when the temperature rises above 110 °C.

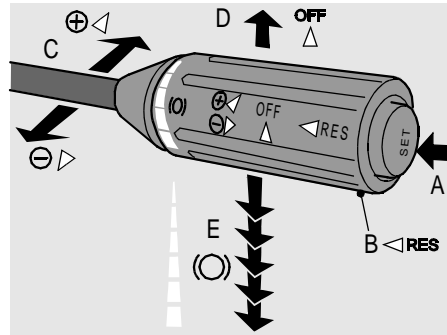

## 11 RIGHT HAND COMBI-SWITCH

### A Set cruise control

Pressing knob A (SET) or B (RESUME) switches off cruise control; or, where cruise control was already switched off, the latest speed is set as cruising speed.

The most recently set speed is held in memory until the ignition is switched off.



**Use the cruise control only when traffic conditions permit the adoption of a steady speed. Do not use cruise control in busy traffic, on**

**roads with many bends or on slippery surfaces.**

### B Resume cruise control

Knobs A and B both have the same function.

### C Acceleration/deceleration

The cruise control can be set to the current speed by moving the combi switch towards or away from the steering wheel.

If a different speed is required to that set, moving the switch briefly towards the steering wheel will raise the speed by 1 km/h.

The speed can be increased smoothly by holding the switch in the raised position.

Moving the switch away from the steering wheel allows deceleration in the same manner.

The vehicle speed may also be increased with the cruise control switched on by depressing the accelerator.

#### D Switching off cruise control

Cruise control is switched off by moving the switch forwards.

Cruise control is also switched off when:

- The footbrake is operated.
- The parking brake is operated.
- The retarder is operated.
- The clutch is operated.
- The engine brake is operated.
- The set/resume switch on the combi switch is operated.

#### E Bremsomat (downhill speed control)/Retarder

The switch has 5 positions to the rear.

##### Position 1: Bremsomat

When driving downhill at the desired speed, the vehicle speed can be held constant at this value by putting the switch in position 1. The retarder determines the necessary braking force. If the braking force needed is greater than the maximum capacity of the retarder it must be supplemented by use of the engine brake or footbrake.

##### Positions 2 to 5: Retarder

Selecting between positions 2 to 5 allows you to switch between 4 different retarder braking forces. This can also be done during a journey. The retarder lamp on the instrument panel constantly gives the driver information about the present situation. Operation of the retarder will be interrupted during ABS activity, but resumes afterwards.

The retarder also operates during the first part of the travel of the footbrake pedal.

The engine brake can be used to supplement the retarder.



**Ensure that, during hill descents, the engine speed does not fall below 1600 rpm, as this reduces cooling, which in turn reduces the effectiveness of the retarder.**

Where necessary, a lower gear should be selected, to raise the engine speed and thereby increase both cooling capacity and the effectiveness of the retarder.

##### Safety requirements

The retarder should be used very cautiously on wet or slippery road surfaces.

The retarder operates on the driven axle only.



**The vehicle may skid.**

Switch off the retarder on very slippery surfaces, to avoid faulty operation see: Vehicle functions page 58.



**During hill descents, operate the retarder with hand control only, not the foot control.**

If the effect of the retarder is insufficient, it may be supplemented with the foot brake or engine brake.

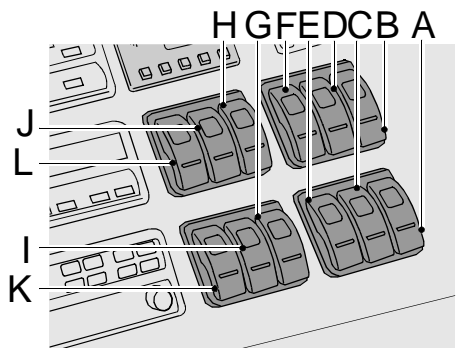

30102A

## 12 CENTRAL DASHBOARD SWITCHES

A	Anti-smog	31
B	Demister	31
C	Left hand side luggage flaps	31
D	Driver's compartment lighting	31
E	Right hand side luggage flaps	31
F	Option switch	31
G	Hazard warning lights	32
H	Option switch	32
I	Bell-push switch (option)	32
J	Option switch	32
K	Hostess call switch	32
L	Option switch	32

### A Anti-smog

When this switch is operated no fresh air is brought in from outside, instead the air inside is recirculated. The anti-smog switch may be found in a tunnel for example, to prevent exhaust fumes getting into the vehicle.

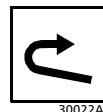

30022A



**The anti-smog switch is automatically switched off after 10 minutes, but the switch must be moved to the off position by hand before it can be operated again.**

### B Demister

Operation of this switch causes the ventilator to run at maximum speed and also opens the heater valve so that the windscreen is demisted as quickly as possible.

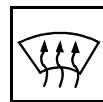

30023A

### C Left hand side luggage flaps

Operation of this switch unlocks all left hand side luggage flaps and switches on the luggage area lighting.



30024A

### D Driver's compartment lighting

Operation of this switch turns on the two adjustable lamps in the driver's compartment. These lamps are also illuminated when the door is opened.



30025A

### E Right hand side luggage flaps

Operation of this switch unlocks all right hand side luggage flaps and switches on the luggage area lighting.

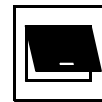

30026A

### F Option switch

This position is not in use and can therefore be used to operate an optional instrument or accessory.

### G Hazard warning lights

Operation of this switch makes the vehicle's indicators flash simultaneously.

The hazard warning system can be used even if the master switch and ignition switch are off. The flashing lamp in the switch is red and flashes.

If the main switch is on then the green direction indicator warning lamp on the instrument panel also flashes.



 **Legal requirements on the use of hazard warning lights vary from country to country.**

### H Option switch

Switch H is not in use and can therefore be used to operate an optional instrument or accessory.

### I Bell-push switch (option)

Bell-push switches are installed above the passengers' heads. They can be operated by the passengers if the switch is on.

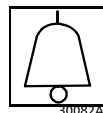

### J Option switch

Switch J is not in use and can therefore be used to operate an optional instrument or accessory.

### K Hostess call switch

Hostess call buttons are fitted above the passengers' heads. These may be operated by the passengers when the switch is on.

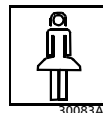

### L Option switch

Switch L is not in use and can therefore be used to operate an optional instrument or accessory.

### 13 VENTILATION GRILLS

The direction of the ventilation grills can be altered to suit personal preference.

Turning the knob on the ventilation grill to zero closes the grill.

### 14 AUDIO

The audio installation can be operated directly via the equipment itself, or via the knobs on the steering wheel in combination with the display.

See the manufacturer's documentation for further detail on the operation of the audio system.

### 15 CIGAR LIGHTER

Push the cigar lighter in. When it is heated it pops back out automatically.

Remove the lighter from its holder. The cigar lighter holder also serves as connection for the inspection light. The inspection lamp can only be used here if its adaptor plug is fitted, see: Plug page 105.

 **An electrical consumer of up to 150W may be connected to this holder.**

## 16 NAVIGATION SYSTEM

For a detailed description of the traffic navigation system, see the manufacturer's information supplied.

## 17 TACHOGRAPH

### General

The tachograph discs have a maximum recording time of 1 day (24 hours). It is therefore necessary to replace the disc(s) every 24 hours. Driver 1 (the current driver) and driver 2 (the current co-driver) each have their own tachograph disc. (If someone changes vehicle he should take his own disc to the new vehicle and register this change on the back of this disc).

When changing vehicles or at the end of a shift the tachograph disc must be removed.



**If the vehicle is not to be used for a time, eg during maintenance or repair, no tachograph disc should be left in place.**

The tachograph drawer can only be opened:

- When the vehicle is stationary.
- When the ignition is on.
- If there is no warning message on the display.



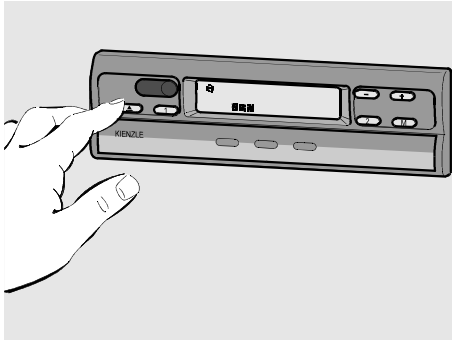



30050A

### Inserting tachograph discs:

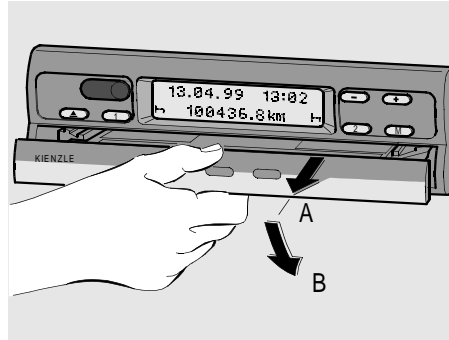
- Push the knob  in. The symbol "opening activated" now appears in the display. At the same time a symbol shows that this may take a few moments. Wait until the drawer is unlocked.



30051A

- **Fixed sliding drawer (A):** pull the sliding drawer out until the stop.
  - **Closeable drawer (B):** pull the drawer out to the stop and swing down.
-  **Do not attempt to swing the fixed drawer down.**
- If it is present, remove the tachograph disc for driver 1 (the driver).

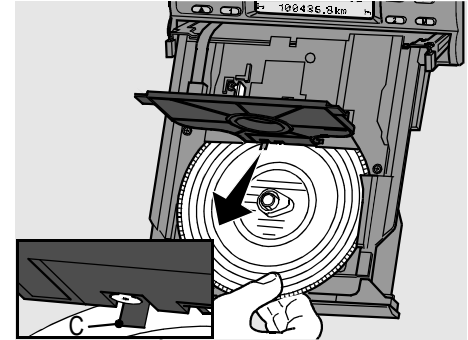

30052A

- Lift the centre plate, and, if it is present, remove the tachograph disc for driver 2 (the co-driver).

 **Before insertion, the tachograph disc must be completed correctly.**

- Place driver 2's tachograph disc in the oval holder with the front uppermost.
- Make sure that the disc is under the spring (C).
- Lower the centre plate.

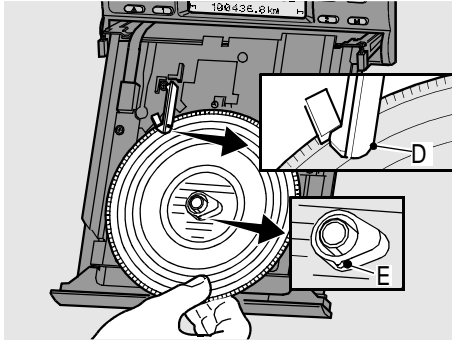

30053A

Insert driver 1's disc on the centre plate front upwards. Ensure that the tachograph disc is placed under holder (D) and cam (E).

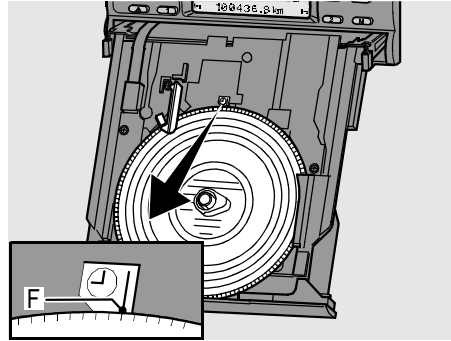

30059A

Check the position of the tachograph disc recorder. The time on the display must be the same as the time on the tachograph disc, by the (F) mark.

### Synchronising the tachograph disc recorder.

- Open the drawer and remove both tachograph discs.
- Close the drawer: the tachograph now synchronises with the time in the display.
- Open the drawer and insert the tachograph discs. the tachograph is now ready for use.

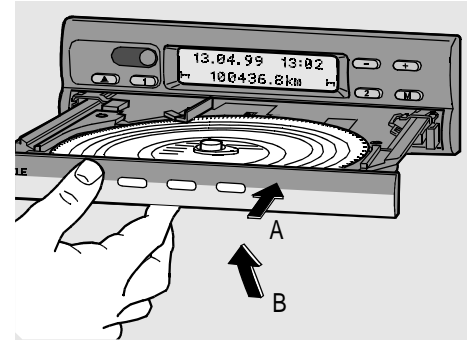

30056A

### Fixed drawer (A):

Slide the drawer in up to the stop.

### Closeable drawer (B):

Bring the drawer to its horizontal position and slide the drawer in up to the stop.



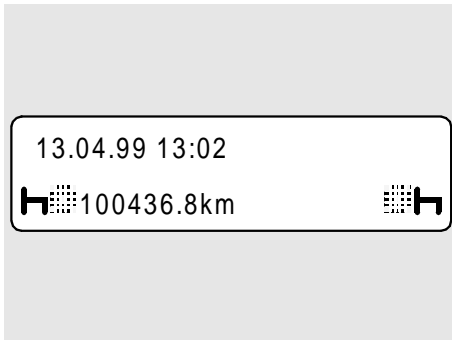

30054A

### Starting data

The starting data such as date, time and mileage are now shown. Symbols also appear, showing the discs inserted and the actual timegroup positions; left for driver 1 and right for driver 2.

### Remarks

The tachograph's time is set as the time in the country where the vehicle is registered. Summer time is adjusted automatically.

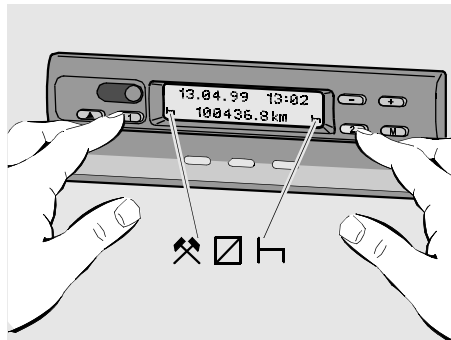

30055A

### Setting timegroups

#### Use by 2 drivers

Driver 1 (the current driver) operates the **1** switch. Push in the switch repeatedly until the required time group appears in the display. Driver 2 (current co-driver) operates the **2** switch. Push in the switch repeatedly until the required time group appears in the display.

When the vehicle is moved the following data appears in the display:

- for driver 1 "⊕" and
- for driver 2 "☐"

#### Use by one driver

For use by only one driver, only the

tachograph disc for driver 1 has to be placed on the centre plate.

- The time group for driver 2 must now be set on rest time "H", otherwise a warning message appears

### Time group divisions

The time groups are divided into:

- ⊕ Driving periods
- ⚡ All other working periods such as loading and unloading
- ☐ Waiting periods
- H Break and rest periods

### Driver changes

Example 1:

When driver 1 and driver 2 swap over the tachograph discs must also be swapped.

Driver 1 (now driver 2) places his disc **below** the centre plate and driver 2 (now driver1) places his disc **above** the centre plate.

The required time groups must now be set.

The new driver 1 now operates switch **1** and driver 2 switch **2**.

### Example 2:

If driver 1 or driver 2 leave the vehicle the driver concerned should take his tachograph disc with him.

The new driver 2 places his tachograph disc under the centre plate, or the new driver 1 places his tachograph disc above the centre plate.

If there is no new driver 2, the time group must be set on  (rest time), otherwise there will be an error message.

### Example 3:

If driver 1 and 2 leave the vehicle then both must remove their tachograph disc from the apparatus.

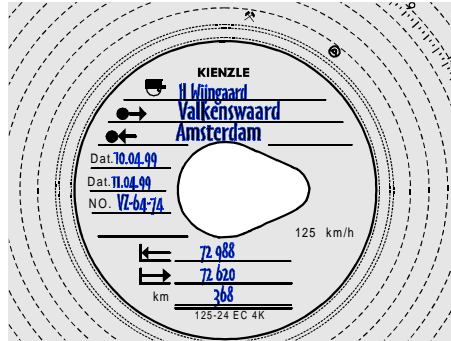

The new crew place their tachograph disc, according to their function (driver 1 or driver 2) in the apparatus.





30058A

### Completion of the middle part of the front of the disc.

Before insertion of the disc:

-  Name of the driver/co-driver
-  Place of departure
- Dat. Date of insertion (upper line)
- No. Vehicle registration number
-  Beginning odometer reading (lower line)

After removing the disc:

-  Place of arrival (bottom line)
- Dat. Date of chart retrieval (bottom line)
-  Ending odometer reading
- Km** Total distance travelled



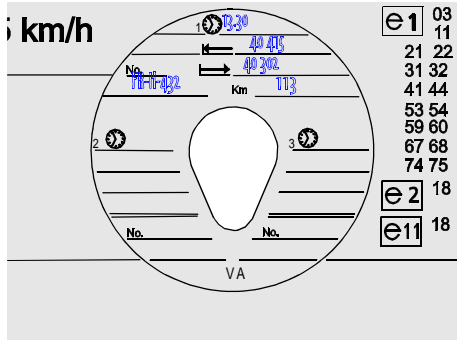

30057A

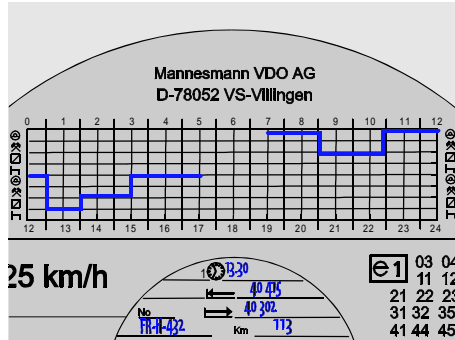

30049A

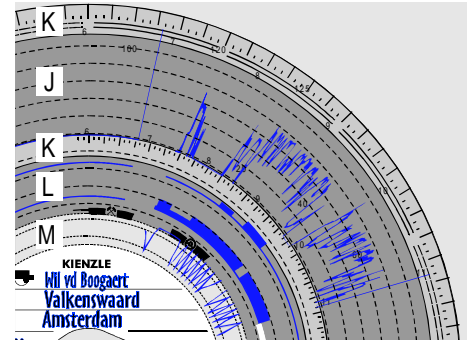

30048A

### Completion of the middle part of the rear of the disc

Up to three vehicles can be entered here:



Time of vehicle change

No. \_\_\_\_\_

Registration number of the new vehicle



Odometer reading at start of journey



Odometer reading at end of journey

Km

Total distance travelled

### Completion of the outer edge of the rear of the disc

This part of the disc can be used to fill in the time by hand if necessary. This may be necessary if the driver/co-driver is working away from the vehicle, so he cannot operate the time group switches, or if the time group breaks down registration. In these cases a line must always be drawn behind the relative symbol.

### Completion of the front of the tachograph disc.

The front of the tachograph disc has the following sectors:

K: Time scales

J: Speed registration

L: Time group registration

M: Distance registration

### Warning light

The warning light on the instrument panel will be illuminated if there is a fault such as:



- No tachograph discs inserted
- A system component fails to function correctly.

To order the correct tachograph discs and for a more detailed description of the tachograph see the manufacturer's information supplied.

### 18 ASHTRAY

The ashtray can be removed for emptying by pushing the clip down and removing the complete ashtray by pulling it forwards

### 19 ACCELERATOR PEDAL

### 20 BRAKE PEDAL

### 21 CLUTCH PEDAL

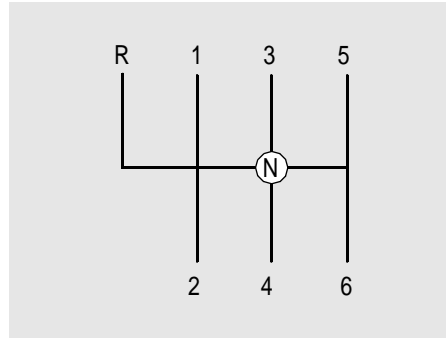

30030A

## 22 GEAR SHIFTING

### ZF 6 S 1600 gearbox

The 6S 1600 is fully synchronised for swift, sure and silent gear changing. There is no need for double-declutching techniques when changing up, or use of the accelerator pedal when changing down.

It is however important to push the gear lever in until the gear is selected. As illustrated, the neutral position is between 3<sup>rd</sup> and 4<sup>th</sup> gear.

The lever moves into the neutral position if it is released when it is in the middle position between gears 1-2 or 5-6.

When changing down, ensure that the speed is not too high for the gear selected.

Reverse gear is selected by moving the lever to the left, through a detente, and may only be selected if the vehicle is completely at rest. The 6S 1600 gearbox is operated through the HGS Hydraulic Gearshift System with servoshift.



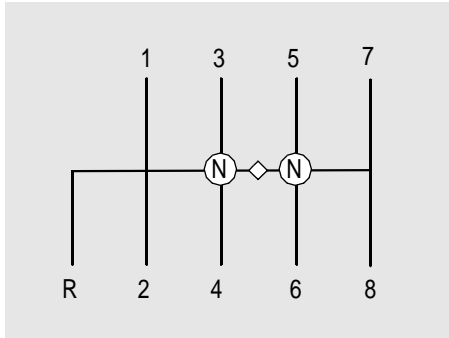

30031A

### ZF 8 S 180 gearbox

The ZF 8 S 180 gearbox is fully synchronised for swift, sure and silent gear changing

The double "H" shifting layout has neutral between 3<sup>rd</sup> and 4<sup>th</sup> (slow group) and 5<sup>th</sup> and 6<sup>th</sup> (fast group)

To select 1<sup>st</sup> or 2<sup>nd</sup>, 7<sup>th</sup> or 8<sup>th</sup> gear the lever must be pushed against spring pressure in the relevant direction.

The lever returns to the neutral position if released when in the middle position.

The slow and fast groups are separated by a stronger spring detente. Reverse gear is selected by moving the lever to the left, through a detente, and may only be selected if the vehicle is completely at rest.

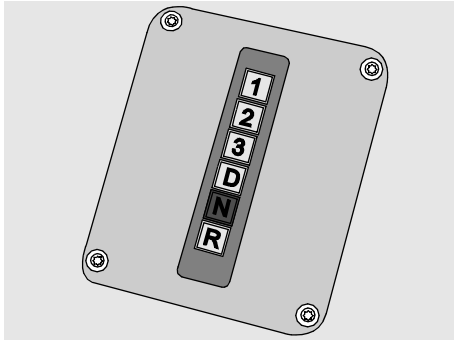

30103A

### ZF 5HP600 Automatic gearbox

The ZF 5HP600 is an automatic gearbox which can also be controlled via push buttons.

- 1-2-3 : Reduced shifting area
- D : Normal driving position
- N : Neutral position
- R : Reverse



The engine can only be started in the neutral position.



Switching from forward to reverse, or vice versa, can only be performed when the vehicle is stationary and the engine is idling.



Never give gas and operate the push buttons simultaneously.

### 23 REFRIGERATOR

The refrigerator has a capacity of 56 litres or 74 cans. It is also suitable for food. The temperature is controlled by thermostat, and is adjusted by turning a knob.



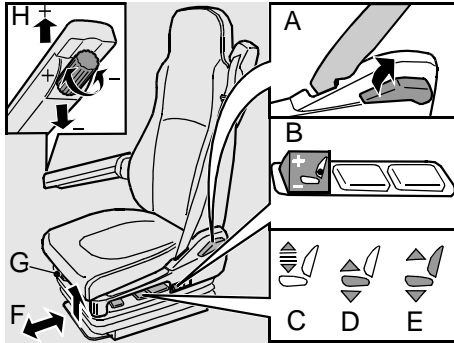

30046A

## 24 DRIVER'S SEAT.

 **Adjust the seat position before driving.**

### A: seat back adjustment

Pull the lever upwards and adjust the seat back to the desired position.

### B: Lumbar support adjustment

The air-cushion in the seat back can be filled (+) or emptied (-) by pushing on the top or bottom of the knob.

### C: quick lowering

Push the handle downward until the seat is lowered to its lowest position. (Useful when getting in or out).

When the handle is returned to its previous position, the seat returns to its former height.

### D: Adjusting seat inclination

Pull the hand lever upward to place the seat in the desired position. Releasing the hand lever locks the seat in position.

### E: Seat height adjustment

Push or pull the handle up or down to adjust the seat to the desired height. The seat is adjustable over a range of 100 mm.

### F: Fore and aft adjustment

Pull the handle up and adjust the seat to the required position. The seat can be adjusted over a range of 180 mm.

### G: Chair seat fore and aft adjustment

Pull the handle upwards and adjust the seat to the required position.

### H: Armrest adjustment (optional)

The armrest can be adjusted by turning the knob.

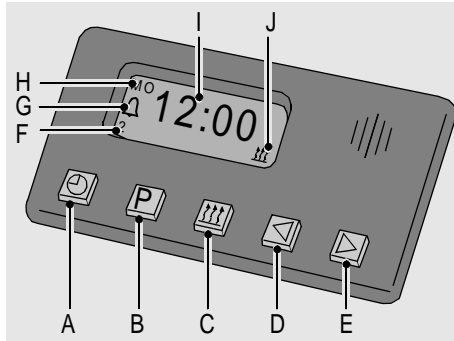

30099A

## 25 STANDBY HEATER TIMER

- A Clock time
- B Program selection
- C Immediate heat
- D Back
- E Forward
- F Memory location
- G Alarm indication
- H Day indication
- I Time indication
- J In service indication

### General

The timer can be used to set heating periods up to 7 days in advance. It is possible to program 3 switch-on times, of which only one may be active. The timer also has an alarm function. When the ignition is switched on the display shows the current time and date.

The operating keys and the display illuminate when the standby heating is in operation.

If the electrical supply is reconnected, for example after servicing, all symbols in the display will flash.

The time and the day of the week must be reset.

### Operation

Any flashing symbol can be adjusted with the ◀ or ▶ keys. If no key is depressed for five seconds the currently displayed time is stored in the memory. Holding the ◀ or ▶ keys down for longer than 2 seconds activates the fast scrolling function.

If the ignition is switched off while the heater is in operation a remaining time of 15 minutes will appear in the display and the heater will continue to operate for that time.

### Switching on

Manually: press (continual heating) key.

Automatically: by programming the start-up time.

### Switching off

Manually: press key

Automatically: by programming the operating time.

When the heating is already in operation: by setting the "remaining time".

### Setting time/day

Hold down key for longer than 2 seconds. The time display will flash.

Adjust the time with ◀ or ▶ keys.

The day display will flash. Adjust the day.

### Display time

When ignition is switched off, press key.

### Set heating start time

Press **[P]** key. The memory location display will flash. Set the heating start time with the **[◀]** or **[▶]** keys. The day display will flash: set the day. Pressing repeatedly on the **[P]** key allows memory locations 2 and 3 to be programmed or returns to the time display.

### Display/set pre-set times

Press **[P]** key repeatedly until the desired memory location is displayed. Pre-set times are cleared by pressing the **[P]** repeatedly until no more times or memory locations are displayed.

### Setting "on" period

The heating must be switched off. Hold down **[◀]** key for 3 seconds ("on" period display will flash). Use the **[◀]** and **[▶]** keys to set the desired "on" time (10 to 120 minutes).

### Setting remaining "on" time

Set the remaining "on" time using the **[◀]** and **[▶]** keys (1 to 120 minutes). The remaining "on" time is the time the heating will continue to operate. This time can only be set if the heater is in service and the ignition is off.

### Setting alarm time

The alarm time is not linked to a day of the week. Press **[P]** key several times until the bell symbol **[🔔]** appears in the display. Set the desired alarm time using the **[◀]** and **[▶]** keys. The alarm will switch itself off 5 minutes after one of the keys is pressed.

### Display/clear alarm times

Press **[P]** key repeatedly until the bell symbol **[🔔]** appears in the display (read off alarm time). Clear the alarm time by pressing the **[P]** key repeatedly until the bell symbol **[🔔]** is no longer displayed.

## 26 HANDGRIP

To the left of the entry step is the handgrip, which is textured to provide extra grip for passengers as they alight.

## 27 VENTILATION GRILL.

The direction of the ventilation grills can be altered to suit personal preference.

Turning the knob next to the grill to zero closes the grill.

## 28 STORAGE BOX.

Before the hostesses seat is a closeable box measuring 33 x 26 x 6 cm which closes itself automatically to avoid blocking the aisle. It can also be used as a writing surface.

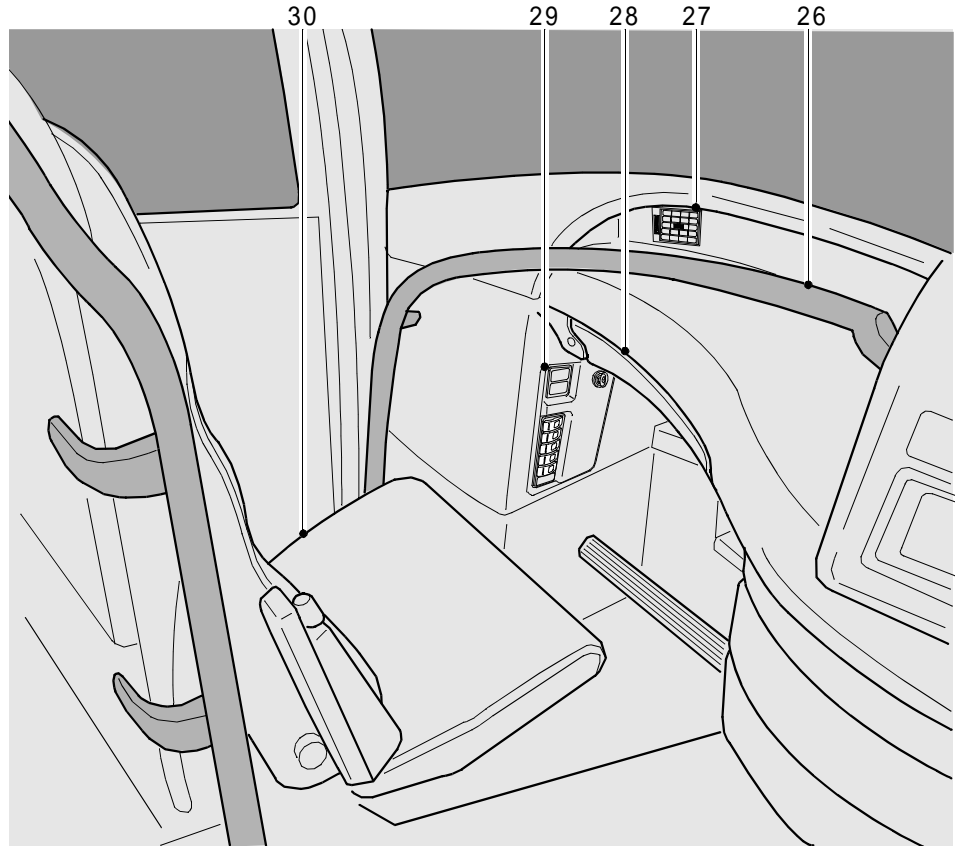

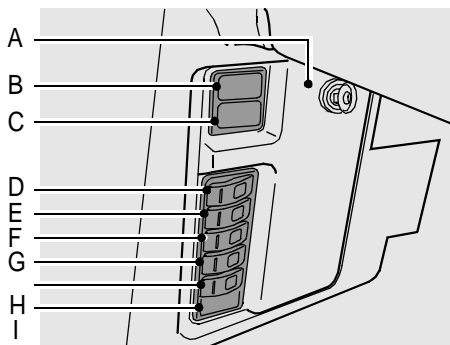

30033A

## 29 LEFTHAND DASHBOARD SWITCHES

A	Closeable switch panel	46
B	Option	46
C	Option	46
D	Opening/closing passengers' door	46
E	Opening and closing central door	46
F	Left hand luggage compartment unlocking	47
G	Right hand luggage compartment unlocking.	47
H	Reading lamp	47
I	Option	47

### A Closeable switch panel

There is space for 8 switches in this panel.

The communications plug for the multiplex system is located behind this panel.

### B Option

Position B is not in use and can therefore be used to operate an optional instrument or accessory

### C Option

Position C is not in use and can therefore be used to operate an optional instrument or accessory

### D Opening/closing passengers' door

Operation of the switch opens the passengers' door: a red light illuminates in the switch. Operating the switch again closes the door.

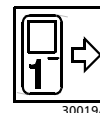

30019A

The door has a safety feature which opens it immediately when its contact strip meets resistance when closing.

This feature also functions when the masterswitch is off.

The door can not be operated at speeds above 3 km/h.

### E Opening and closing central door

Operating the switch opens the central door and illuminates the red light in the switch. Operating the switch again closes the door.

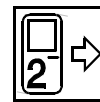

30020A

The door has a safety feature which opens it immediately when its contact strip meets resistance when closing.

This feature also functions when the masterswitch is off.

The door can not be operated at speeds above 3 km/h.

## F Left hand luggage compartment unlocking

Operating this switch unlocks all left hand luggage compartment doors.



## G Right hand luggage compartment unlocking.

Operating this switch unlocks all right hand luggage compartment doors.



## H Reading lamp

Operation of the switch illuminates the reading lamp next to the hostesses seat.



## I Option

Switch I is not in use and can therefore be used to operate an optional instrument or accessory.

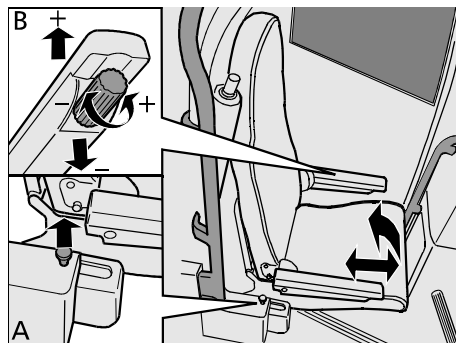

30042A

## 30 HOSTESSES SEAT

Pull the knob upwards and swing the hostesses seat open

By lifting the front, the seat can be placed in several positions for and aft and the angle of the back support changes accordingly.

Both armrests can be adjusted in height by turning the rotary knob (see illustration B).

## MESSAGES ON THE DISPLAY

### General

Various symbols appear on the display when the ignition switch is turned on.

If the engine is running, messages may appear on the display, which are divided into four priority levels.

If there are further messages, this is shown by the following symbol.



Priority 1 and 2 appear on the fault menu.

Priority 3 and 4 appear on the driving menu.

If there are several messages, priority 1 messages have priority over others.

If the fault menu is activated the priority 1 and 2 messages can be read one by one by holding the knob ⊖ on the steering wheel for around one second.

When all messages have been read, all their symbols (including priority 3 and 4) are displayed without text in the driving menu.

## Priority 1

There is an urgent problem which may give rise to risk of personal injury or damage to the vehicle.

This is signalled by a pulsing buzzing sound, and the illumination of the red stop symbol on the instrument panel.



A symbol and warning text also appears in the fault menu in the display.

Stop as soon as possible in a safe place and switch off the engine and ignition.

Trace the fault and correct it or have it corrected.

If the problem is corrected the buzzing and warning symbol will disappear automatically.



Warning  
Cooling water supply low in the pipes.



Warning  
Driver's sleeping compartment.



Safety warning  
Preheater compartment temperature high



Safety warning  
Luggage compartment temperature high



Safety warning  
Engine compartment temperature high



Safety warning  
Air pressure circuit 1 low



Safety warning  
Air pressure circuit 2 low



Warning  
Coolant temperature high



Warning  
Emergency door open



Warning  
Oil pressure low



Safety warning  
ECAS fault, see: Air suspension (ECAS) page 71



Warning  
Oil temperature of the automatic gearbox high



Warning  
Upec motor management problem

## Priority 2

There is a problem which may cause damage to the vehicle if not corrected early.

This is signalled by a 5 second buzzing tone and the illumination of the orange warning symbol on the instrument panel.



A symbol and warning text also appears in the fault menu in the display.

Stop at the first opportunity and switch off the engine and ignition. Trace the problem and correct it or have it corrected.

When the problem is corrected the warning symbol disappears automatically.



Warning  
ECAS fault, see: Air suspension (ECAS) page 71



Warning  
Alternator 1 charging current fault



Warning  
Alternator 2 charging current fault



Warning  
CXB problem (CAN extension box) or the motorstop in the engine compartment is activated

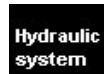

Warning  
Hydraulic oil temperature high



Faulty connection or defect in the multiplex wiring system.



Tachograph fault



Safety warning  
Air pressure circuit 1 low



Safety warning  
Airpressure circuit 2 low



Warning  
Retarder problem



Warning  
Emergency hammer not in place



### Priority 3

Status is indicated by the illumination of a symbol in the driving menu on the display.

If the driving menu is not open it is opened automatically.

You may continue to drive but check the origin of the warning message and correct it at the first opportunity.



Brake pad wear indicator  
Brake pads due for replacement



Fuel indicator  
Fuel level is low



ECAS message, See: Air suspension (ECAS) page 71

### Priority 4

Report of operation of system or function in the display driving menu. If the driving menu is not open it is automatically opened.



Hostess call operated by passenger



Stop button operated by passenger



Refrigerator door in upper part of toilet opened.



The symbol flashes slowly when the anti-skid system is operating



Toilet occupied



Preheater system activated



Coffee machine in use (optional)



Fuel pipe heating (Optional)



Central greasing (Optional)

## DISPLAY

### General

Operation of the master switch brings up the start-up screen.

If applicable a language may be selected.

If no new selection is made then the last used language will be selected automatically and main menu 1 will appear in the display.

All necessary adjustments to the various components such as air conditioning and audio/video can be performed via the knobs on the steering wheel.

The various adjustments possible via the display are described in this section.

Switching on the ignition brings up the driver menu on the display, with various symbols shown.

The top area is divided into three sections, that at the right giving the outside temperature.

If the outside temperature lowers below 4 °C the right section turns into red.



### **Warning! The road might be slippery**

In the central section, the channel selection for the driver's space is shown to the right and that for the passenger area is shown to the left.

### **Fault menu**

If the engine is running and there are one or more faults, that is reported in the fault menu by means of a symbol with accompanying text, see: Messages on the display page 47.

After the faults have been read, the fault symbol is shown, without text, in the driver menu, and the relevant symbol may remain lit or flash.

### **Code**

In this description the various displays are shown with a code which gives the sequence in which the operating buttons must be pushed in order to reach the relevant display.

The code works from the driver menu





30102A

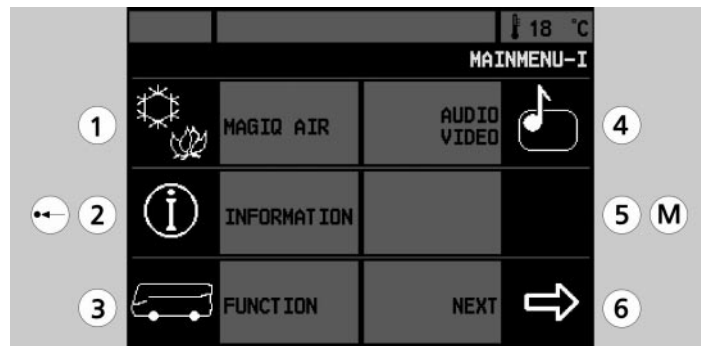

30099A

## Start-up screen

- ① - ④ Choose the appropriate language. If no choice is made, the last-used language will be selected and main menu 1 will appear automatically
- ② - ⑤ Not in use
- ③ - ⑥ Not in use
- ← To driver menu
- (M) To menu one level up

## Main menu I

code: M

- ① To Magiqair (air conditioning) menu
- ② To vehicle information menu
- ③ To vehicle function menu
- ④ To audio/video menu
- ⑤ Not in use
- ⑥ To main menu II
- ← To driver menu
- (M) To menu one level up

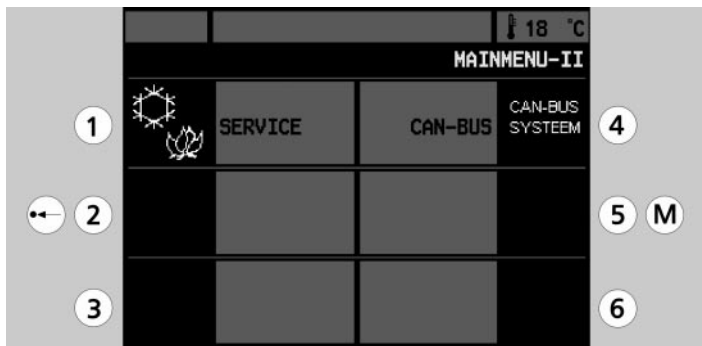

30063A



30060A

## Mainmenu II

code: M-6

- ① To service menu of the climate system
- ④ To the diagnose menu of the can-bus system
- ② - ⑤ Not in use
- ③ - ⑥ Not in use
- ← To driver menu
- (M) To menu one level up

## Driver menu

- ① up to ⑥ Not in use
- ← To driver menu
- (M) To menu one level up

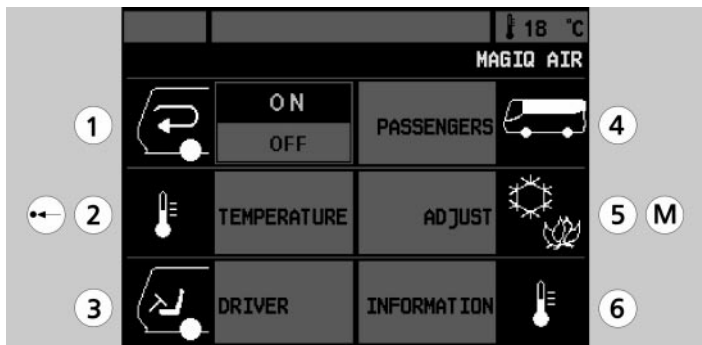

30064A

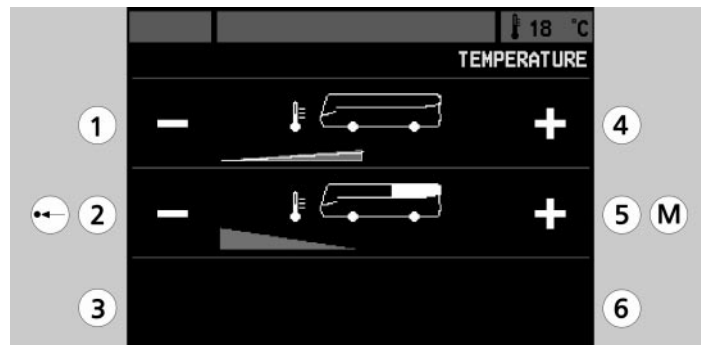

30065A

### MagiQair air conditioning system

code: M-1

- ① Recirculating air: operation closes off the outside air supply and interior air only is circulated
- ② To temperature setting menu
- ③ To driver's compartment air conditioning menu
- ④ To passengers' area air conditioning menu
- ⑤ To system adjustment menu
- ⑥ To temperature information menu
- ← To driver menu
- M To menu one level up

### Temperature setting

code: M-1-2

- ① - ④ General temperature setting (18 to 28 °C)  
1 = Lower temperature, 4 = higher temperature
- ② - ⑤ Temperature setting in the rear part of the coach, varying by +2 °C and -2 °C from the general temperature setting  
2 = temperature lower, 5 = temperature higher
- ③ - ⑥ Not in use
- ← To driver menu
- M To menu one level up



30066A

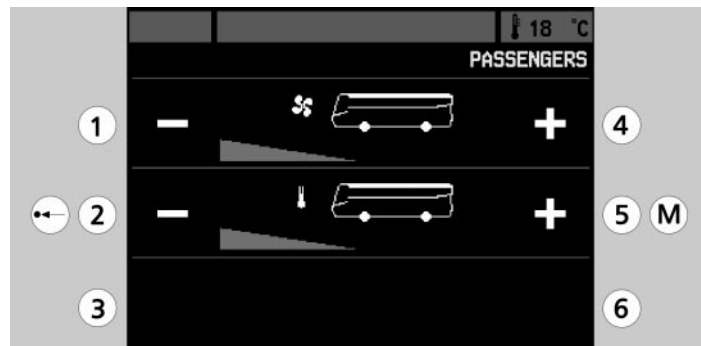

30067A

#### Air conditioning setting, drivers compartment code: M-1-3

- ① – ④ Driver's compartment ventilation  
1 = Lower rate, 4 = higher rate
- ② – ⑤ Air flow adjustment  
Stepless adjustment between upper and lower  
2 = lower, 5 = upper
- ③ – ⑥ Temperature setting in the front part of the coach, varying by +5 °C and -5 °C from the general temperature setting  
3 = temperature lower, 6 = temperature higher
- ← To driver menu
- (M) To menu one level up

#### Passenger area air conditioning adjust- code: M-1-4

- ① – ④ Passenger area roof unit ventilation rate (-15% and +15% variance from the general setting)  
1 = lower rate, 4 = higher rate
- ② – ⑤ Temperature adjustment in the central area of the vehicle (overhead vent), -2 °C and +2 °C variance from the general setting  
2 = lower temperature, 5 higher temperature
- ③ – ⑥ Not in use
- ← To driver menu
- (M) To menu one level up

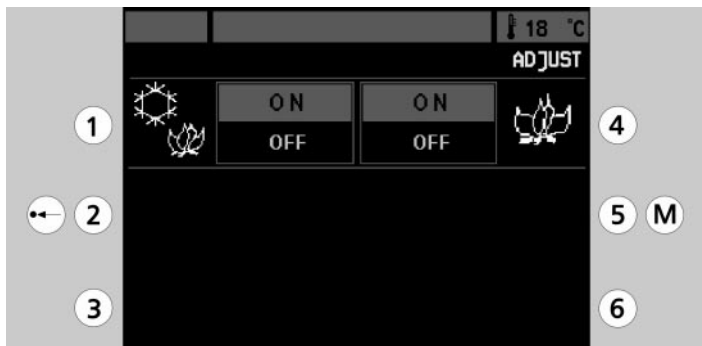

30068A

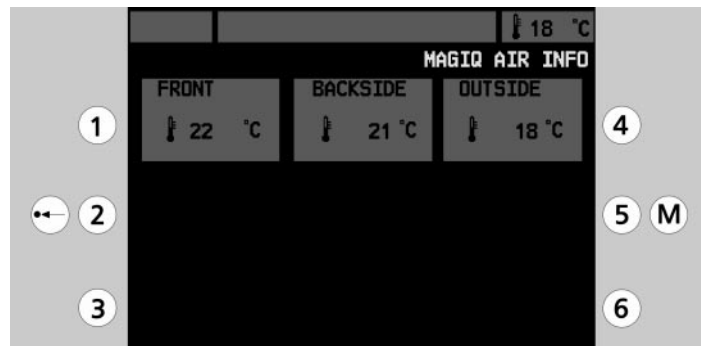

30070A

### System adjustments

code: M-1-5

- ① Magiqair climate system on/off
- ④ Pre-heating on/off
- ② – ⑤ Not in use
- ③ – ⑥ Not in use
- ← To driver menu
- M To menu one level up

### Magiqair information

code: M-1-6

This display shows the actual temperature outside, and at the front and rear of the vehicle.

- ① up to ⑥ Not in use
- ← To driver menu
- M To menu one level up

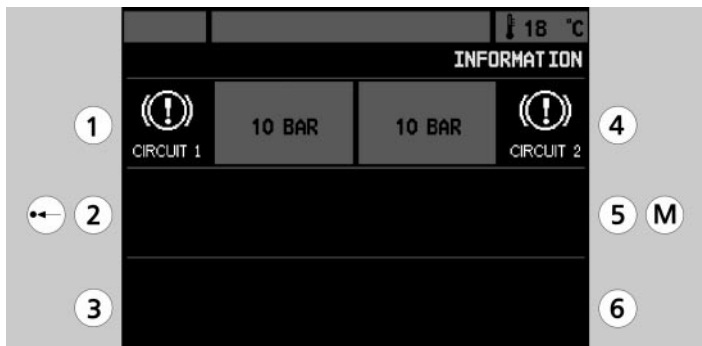

30071A

## Vehicle information

code: M-2

This display shows the air pressures in brake circuit 1 and brake circuit 2.

① up to ⑥ Not in use

← To driver menu

M To menu one level up

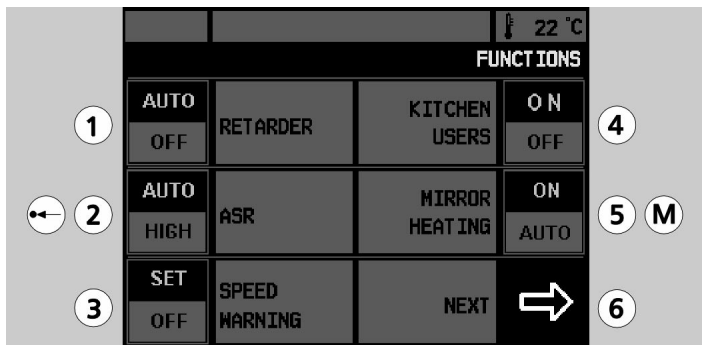

30100A

## Vehicle functions



code: M-3

Vehicle functions and options can be switched on and off via this display.

- ① Normally the retarder is switched on and is brought into operation by the initial movement of the footbrake pedal  
This extends the life of the brake components  
Operating this control knob switches off the retarder function completely

- ② The ASR system is always switched on; operating this switches allows increased slip of the driven wheels before the system comes into play  
The ASR system prevents the driven wheels slipping both when moving off and when in motion, in order to obtain optimal traction and stability  
Depending on the road conditions, the ASR system regulates engine power and/or braking power when excessive wheelspin is detected  
On uniform roads, control is primarily by means of reduction of engine power  
The ASR symbol on the display will flash slowly when the ASR system is in operation

 **Operation of the ASR system is an indication of slippery road surfaces.**

- ③ If "speed warning" is switched on at a particular speed, the driver is warned by means of a buzzer when he exceeds the set speed
- ④ Kitchen electrical consumers: switching on allows use of the kitchen equipment.
- ⑤ Mirror heating is on by default when the temperature falls below 15°C  
Mirror heating can also be switched on at temperatures above 15 °C by operating this control knob
- ⑥ To function menu II
-  To driver menu
-  To menu one level up

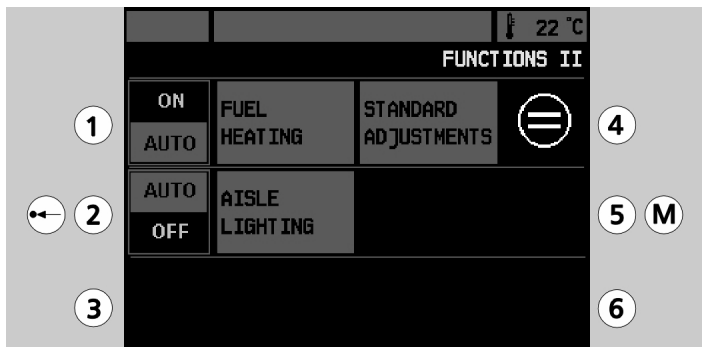

30101A

## Vehicle functions II

code: M-3-6

Vehicle functions and options can be switched on and off via this display.

- ① If the temperature drops below -15 °C the fuel pipe heating is switched on standardly, although it can also be switched on manually if temperatures are higher than -15 °C
- ② Operation switches off lower lighting at the sides of the central gangway
- ③ Not in use
- ④ The climate and vehicle settings return to their standard positions and in the display mainmenu 1 appears
- ⑤ - ⑥ Not in use
- ⑤ - To driver menu
- ⑥ To menu one level up

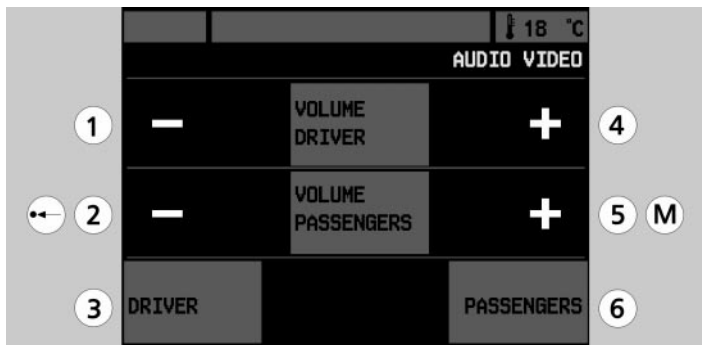

30073A

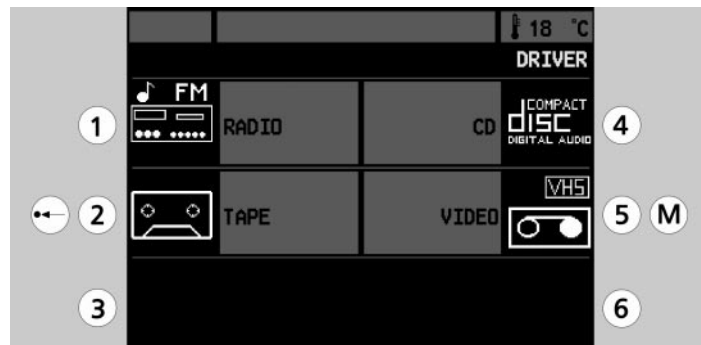

30074A

## Audio/Video

code: M-4

- ① – ④ Volume adjustment, driver's compartment  
1 = lower volume  
4 = higher volume
- ② – ⑤ Volume adjustment, passenger area  
2 = lower volume  
5 = higher volume
- ③ To driver's compartment source selection
- ⑥ To passenger area source selection
- ← To driver menu
- Ⓜ To menu one level up

## Source selection, driver's compartment code: M-4-3

- ① Radio operating menu
- ② Cassette player volume adjustment
- ④ To the CD operating menu (the CD player also switches on)
- ⑤ To video operating menu
- ③ – ⑥ Not in use
- ← To driver menu
- Ⓜ To menu one level up

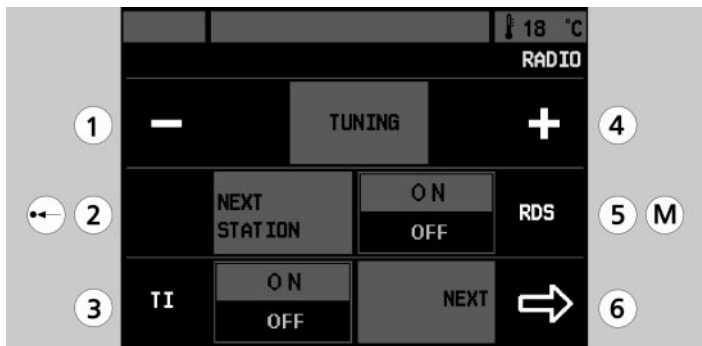

30076A

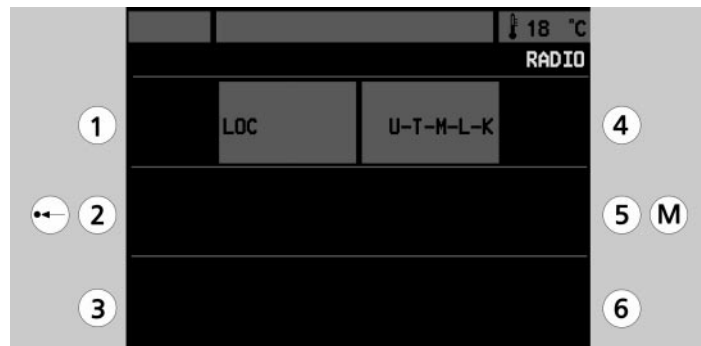

30077A



### Radio operation, driver's compartment code: M-4-3-1

- ① – ④ Channel selection  
1 = Frequency down  
4 = Frequency up
- ② To next pre programmed channel  
Choice of 6 channels
- ③ Traffic information on/off
- ⑤ RDS (radio data system) on/off
- ⑥ To radio operating menu 2
- ← To driver menu
- M To menu one level up

### Radio operations 2 driver's compartment code: M-4-3-1-6

- ① Switch between LOC; DISTANCE; MANUAL  
LOC = local transmitters only  
DISTANCE = retain channel over long distance  
MANUAL = manual tuning
- ④ Choice between radio bands
- ② – ⑤ Not in use
- ③ – ⑥ Not in use
- ← To driver menu
- M To menu one level up

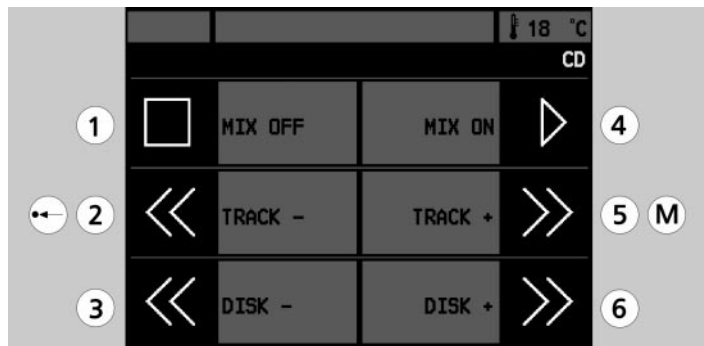

30078A



30079A

### CD operation, driver's compartment

code: M-4-3-4

- ① Switch off random play
- ② Previous number
- ③ Previous CD
- ④ Switch on random play
- ⑤ Next number
- ⑥ Next CD
- ← To driver menu
- (M) To menu one level up

### Video operation, driver's compartment code: M-4-3-5

- ① Stop
- ② Rewind
- ④ Start
- ⑤ Fast forward
- ③ - ⑥ Not in use
- ← To driver menu
- (M) To menu one level up

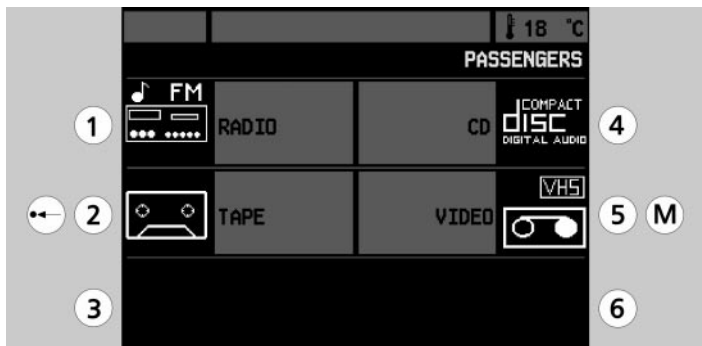

30075A

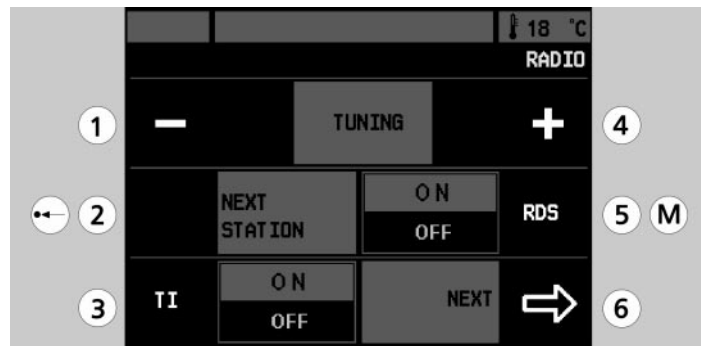

30076A

### Source selection, passengers' area

code: M-4-6

- ① To radio operation menu
- ② Cassette player volume
- ④ To CD operating menu (the CD player also switches on)
- ⑤ To video operating menu
- ③ - ⑥ Not in use
- ← To driver menu
- Ⓜ To menu one level up

### Radio operation, passengers' area

code: M-4-6-1

- ① - ④ Channel selection  
1 = Frequency down  
4 = Frequency up
- ② To next preprogramming channel  
Choice between 6 channels
- ③ Traffic information on/off
- ⑤ RDS (Radio Data System) on/off
- ⑥ To radio operating menu 2
- ← To driver menu
- Ⓜ To menu one level up

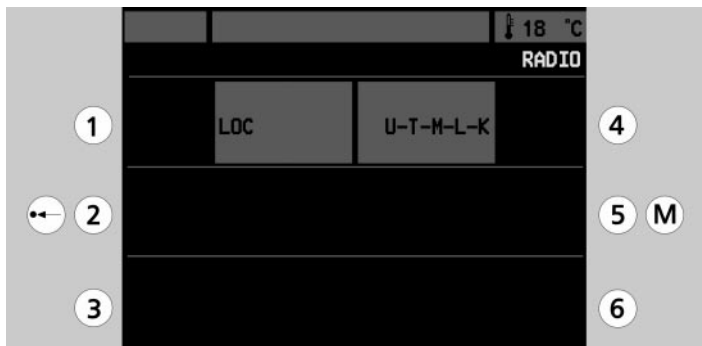

30077A

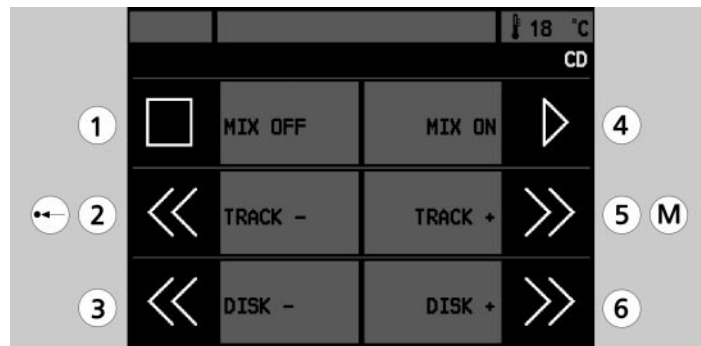

30078A

**Radio operation 2 passengers area** code: M-4-6-1-6

- ① Switching between LOC; DISTANCE; MANUAL  
LOC = local transmitters only  
DISTANCE = retain channel over long distance  
MANUAL = manual tuning
- ④ Choice between
- ② - ⑤ Not in use
- ③ - ⑥ Not in use
- ← To driver menu
- (M) To menu one level up

**CD operation, passengers' area** code: M-4-6-4

- ① Switch off random play
- ② Previous number
- ③ previous CD
- ④ Switch on random play
- ⑤ Next number
- ⑥ Next CD
- ← To driver menu
- (M) To menu one level up



30079A

### Video operation, passengers' area

code: M-4-6-5

- ① Stop
- ② Rewind
- ④ Start
- ⑤ Fast forward
- ③ - ⑥ Not in use
- ← To driver menu
- M To menu one level up

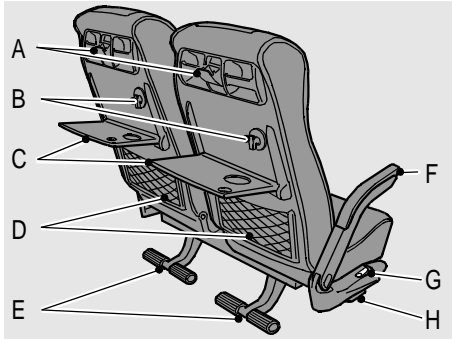

30043A

## PASSENGERS' AREA

### Passenger seats

The seats fitted in the vehicle may vary (depending on the chosen option) from those described here.

- A Ashtrays, removable for easy cleaning
- B Knob to secure hinged table.
- C Hinged table with space for drinking-glass.
- D Magazine rack
- E Footrest, adjustable by moving first up, then down.
- F Armrest next to aisle, folds away by swinging first upwards, then down.
- G Knob (on aisle side) and handle (on window side) for back support adjustment.  
The seat back can be adjusted through 35 ° to 45 °, depending on the version fitted.
- H Knob for sideways adjustment of the aisle side seat.

### Torque settings for passenger seat mounting

Kiel	
gangway side	38 ± 3 Nm (M10)
side wall side	38 ± 3 Nm (M10)
	28 ± 3 Nm (M8)

Vogel	
gangway side	35 Nm (M10)
side wall side	35 Nm (M10)
	25 Nm (M8)

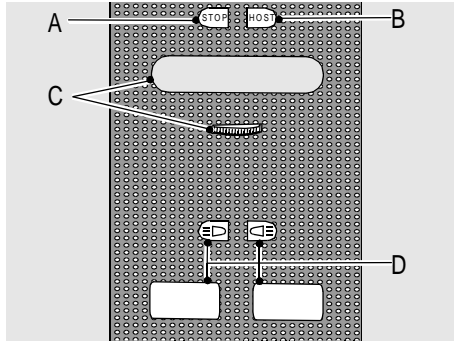

30044A

### Personal setting units

Above each seat is a unit allowing ventilation and reading lamps to be adjusted to personal preference. As an option, a speaker, stop and hostess call buttons can be fitted to each personal setting unit.

A The (optional) stop switch can only be operated by the passenger when permitted by operation of dashboard switch 12 I: see Bell-push switch (option) page 32. If the stop switch is operated the stop symbol appears on the display and a buzzer sounds for several seconds. Opening the door resets this function.

A In the GB version there are bell-push switches only in the personal control units. A buzzer sounds for several seconds if the switch is operated. A lamp will also illuminate in the relevant switch, which will be extinguished by the opening of the main door.

B The hostess call switch can only be operated by the passenger when permitted by operation of dashboard switch 12 K, see: Hostess call switch page 32

If the hostess call switch is operated the hostess symbol appears on the display and a buzzer sounds for several seconds. The lamp in the push-button above the passenger's head will continue to be illuminated until it is pushed again.

C Rotary knob for ventilation adjustment.

D Operation of this switch turns on the relevant reading lamp.



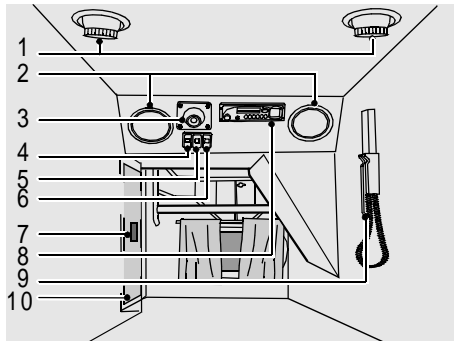

30039A

## DRIVER'S SLEEPING COMPARTMENT

### General

The driver's sleeping compartment is furnished with a 10 cm thick mattress of 64 x 227 cm and is entered via the left or right luggage flaps or the roller shutter in the central entry.

### 1 AIR OUTLETS

There are two air outlets on each side allowing fresh air supply by two fans.

### 2 LOUDSPEAKERS

### 3 READING LAMPS

Two reading lamps are fitted in the driver's sleeping compartment which may be switched on or off simultaneously with either switch 4 or 7.

### 4 LIGHT SWITCH

Switches the reading lamps on or off (two-way switching with switch 7).

### 5 WARNING SWITCH

Operation of this switch gives the driver a warning message on the display.



### 6 VENTILATOR SWITCH

Switch has 3 positions:

Position 1: Off

Position 2: 1 Ventilator

Position 3: Not in use

### 7 LIGHT SWITCH

Next to the roller shutter is a switch for switching reading lamps on or off (two-way switching with light switch 4).

### 8 RADIO/CASSETTE PLAYER (OPTIONAL)

For a detailed description of the radio/cassette player, see the manufacturer's documentation supplied.

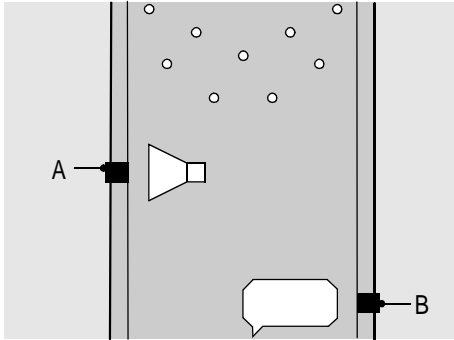

30100A

## 9 INTERCOM INSTALLATION

The intercom unit can be used to speak to the driver from the sleeping compartment and vice versa.

A call is made by pushing button A which sounds a buzzer in the other receiver.

Speak while holding down button B.

## 10 ROLLER SHUTTER

The roller shutter in the middle entry provides the best access to the sleeping compartment.



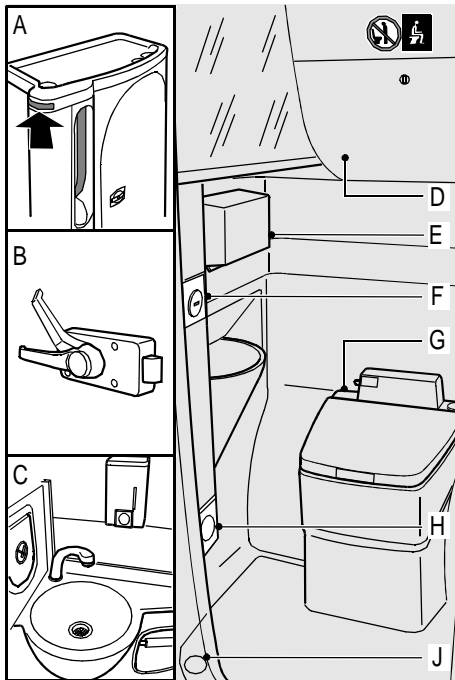

30047A

## TOILET

### General

Depending on the chosen option, the toilet may differ from that described here.

The toilet air extraction operates continuously from the switching on of the master switch.

A: Occupied sign, which is illuminated when the toilet lighting is turned on with

The toilet signal also appears on the display.



B: Lock, lockable from inside by moving the handle upwards, and from outside with a key.

C: Sink with 70 litre reservoir. The tap is operated (with the knee) by switch (H). To the left of the sink is a waste bin fitted with a smoke detector.

D: Locker for storing toilet paper and cleaning materials.

E: Paper towel dispenser

F: Light switch for two halogen spotlights and the occupied light.

G: Chemical toilet with level indicator, and flushing via a knob. For a detailed description of the WC see the manufacturer's information supplied.

H: Knee-operated switch, for operating tap.

J: Outlet, to allow water to drain away easily during cleaning.



**Park the vehicle in an appropriate place before cleaning the toilet.**

## KITCHEN.

For a detailed description of the on-board kitchen see the manufacturer's information supplied.

## NAVIGATION SYSTEM.

For a detailed description of the navigation system see the manufacturer's information supplied.

## AIR SUSPENSION (ECAS)

The Electronically Controlled Air Suspension (ECAS) is operated via a microprocessor.

The vehicle height is stored in the microprocessor memory. If the actual vehicle height is different, this is adjusted for automatically.

### ECAS control symbols.

Any disturbance to the ECAS system is reported by the illumination of ECAS symbols on the display, see: Messages on the display page 47

If the red ECAS symbol flashes in the driver menu there is a serious fault.

- The level can not be checked or adjusted.

If the red ECAS symbol illuminates continuously in the driver menu there is a minor fault such as:

- No speed signal.
- The level can only be monitored to a limited extent.
- Low voltage, between 7.5 and 18 volts.
- Raising inoperative, regardless of valve position.



If the yellow ECAS symbol flashes in the driver menu, the storage pressure is too low.

If the yellow ECAS symbol is continuously illuminated, the level in question varies from the normal level: raising or kneeling required.

### Raising/kneeling

The ECAS system is equipped to allow the whole vehicle to be raised, or to allow the front or rear axle to be kneeled separately.

The capability to raise the vehicle may be used if more ground clearance is required, for example when boarding a ferry. The kneeling function may be used to allow passengers to alight more easily.

The vehicle is raised or kneeled by means of switch: Raising/kneeling, front page 22.

Position 0: Raise (front and rear)  
Position 1: driving position (neutral)  
Stand 2: Kneel (front)

The vehicle can be raised or the rear kneeled with switch: Raising and kneeling, rear page 22.

Position 0: raise (front and rear)  
Position 1: driving position (neutral)  
Position 2: kneel (rear)

### Anti-tilt system

The vehicle can also be fitted with an anti-tilt system (obligatory in the UK). Any vehicle can drive along a cambered surface at a certain angle. If this angle becomes too great, the vehicle will topple over.

The anti-tilt system increases the toppling angle by 5°. This means that the vehicle will not topple over so early.

## STEERING GEAR

The steering gear is hydraulically powered.



**In temperatures below 0 °C it is recommended to run the engine for several minutes, after a cold start, before moving the steering.**



**Do not continue to turn the steering wheel if the wheels meet an obstacle or after reaching full lock: there is a high probability of damage to the steering gear.**

The turning angle is 60° and there are 6.8 turns from lock to lock



**The vehicle can also be steered without power steering, for example if the engine is not running, but this requires considerable force.**

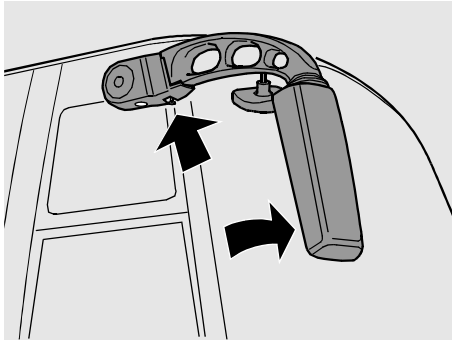

30040A

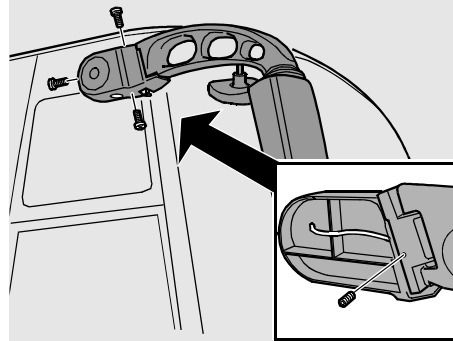

30104A

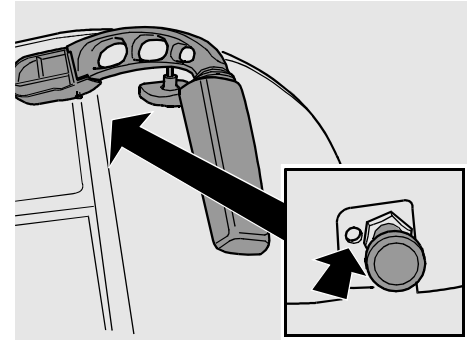

30041A

## MIRRORS

The mirrors are warmed and adjusted electrically and are equipped on both sides with width indication mirrors. The heating functions automatically but can be switched on manually; see: Vehicle functions page 58.

### Folding mirrors in

Pulling the pin below the mirror housing allows the mirror to be folded in.

### Removing mirrors

If it is necessary to remove the mirrors, for example for washing, first remove the covers (3x screw). Remove the securing bolt which locks the mirror.

Place a punch (from the toolset) in the slot in the underside of the housing and tap the punch with a hammer. The mirror can now be removed completely.

## Replacing mirrors

The mirrors are replaced by hooking them over the housing and pulling down until the stop is met.

Install the securing bolt and install the cover (3x screw).



**If the mirrors do not vibrate and the adjustment operates correctly, this indicates that they are properly fitted.**

### 3 SAFETY REQUIREMENTS AND EMERGENCY PROCEDURES

GENERAL .....	77
ROOF HATCHES.....	77
EMERGENCY OPERATION OF DOORS AND FLAPS.....	78
FIRE EXTINGUISHER .....	79
SAFETY BELTS .....	80
FIRST AID KIT .....	80
HAZARD WARNING LIGHTS.....	81
EMERGENCY HAMMERS .....	81
EMERGENCY PROCEDURES.....	81

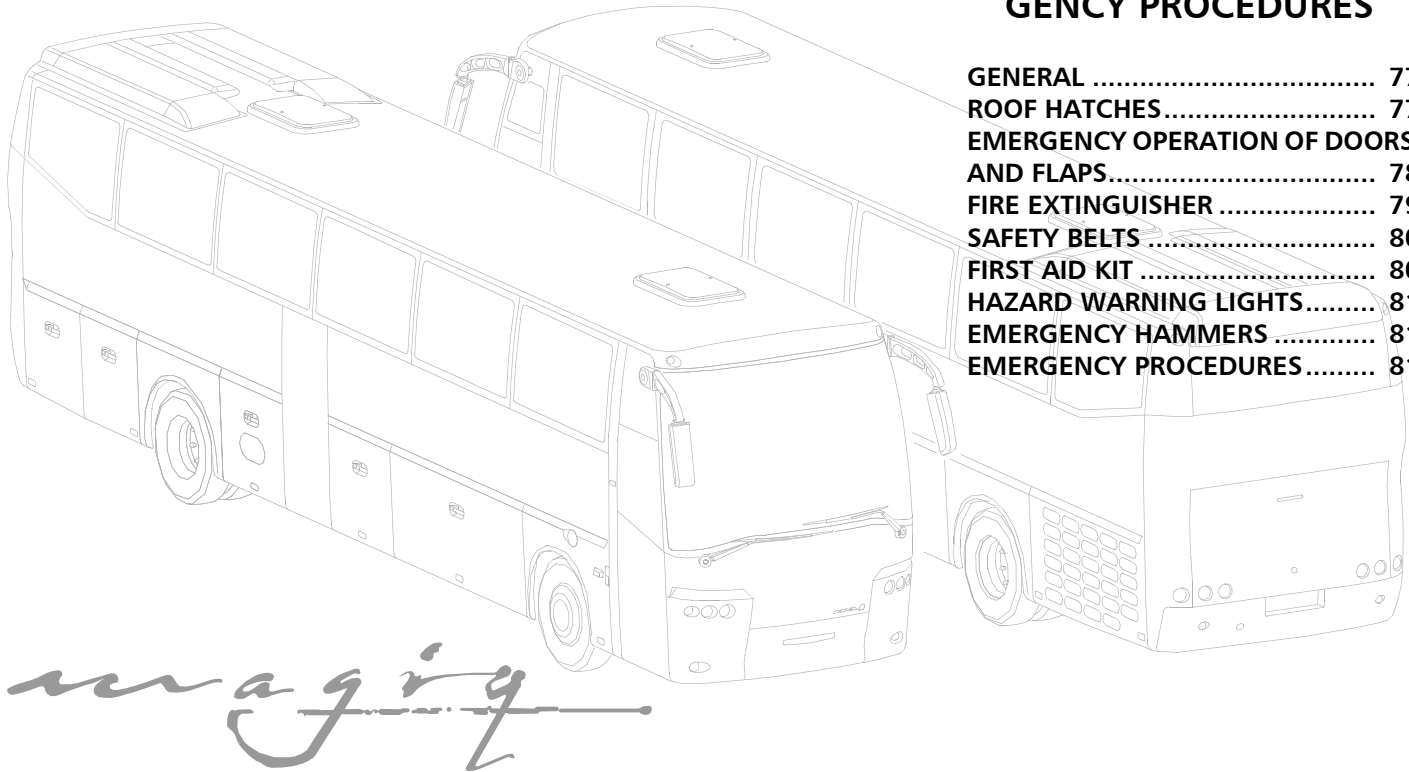



## GENERAL

The driver should adequately inform the passengers about emergency procedures, and ensure that all emergency exits are unlocked and unobstructed before departure. In an emergency the driver and/or the passengers may leave the vehicle via the doors, windows or roof-hatches.

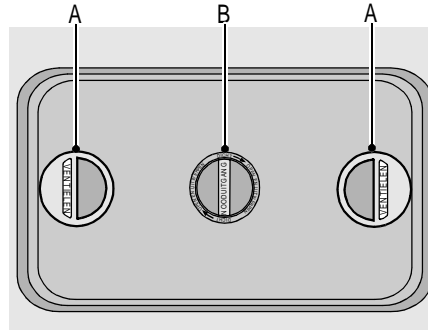

20001A

## ROOF HATCHES

The vehicle is provided with two roof-hatches.

The roof-hatches have a ventilation position, and can be removed completely if needed as an emergency exit.



**The roof-hatch must not be used as a means of access to the roof for cleaning work.**

## Ventilation position

The roof hatch can be opened fore and aft for ventilation purposes by pushing A to the outside. To re-close the hatch, pull A towards the inside. The roof hatches may be placed in the ventilation position when in motion, but if only the front ventilation position is used, the speed should not rise above 100 km/h.

## Removal

The roof hatches are removed by turning handle B in the direction of the arrow and pushing the hatch out. The hatch remains attached by safety straps.



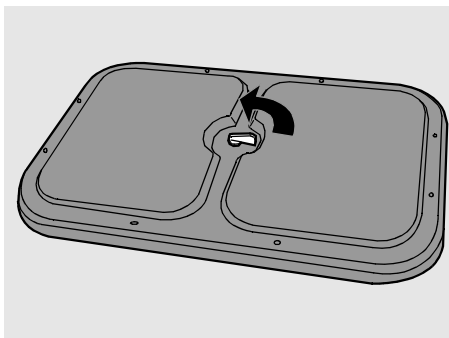

20013A

The hatches may also be removed from outside by turning the knob to the left.



20009A

## EMERGENCY OPERATION OF DOORS AND FLAPS

### Passenger and central door

The passenger and centre doors are opened with a handle located on the outside next to the door. This handle is lockable with a key. If the handle is unlocked and the normal door operation is not functioning, the door can still be opened by pulling the handle completely upwards, which depressurises the system allowing the door to be opened by hand.

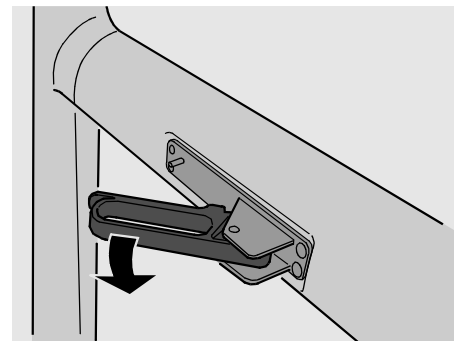

20008A

The passenger and centre doors can be opened from inside in the case of an emergency, by operating the handle located above the passenger and central doors. The handle seal must be broken and the handle pulled towards the user.

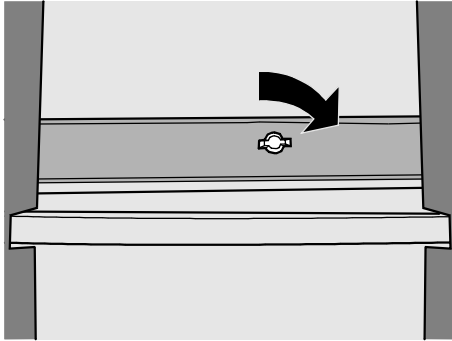

20012A

### Sleeping compartment hatch

The left sleeping compartment hatch can be unlocked from inside by giving the knob a quarter turn to the right, and the hatch can then be opened. The right sleeping compartment hatch can only be opened from outside, by means of a key.



**When the middle door is open only the left hand sleeping compartment hatch can be opened.**

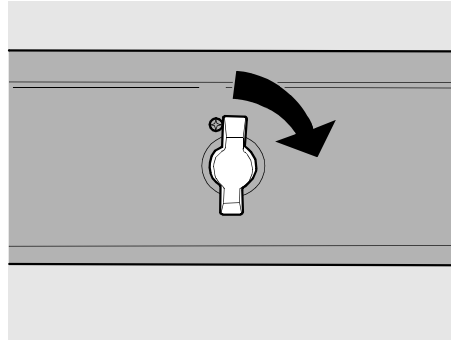

20015A

### Luggage flaps.

If no electrical supply is available, the luggage flaps can only be unlocked by giving the knob inside the flap a quarter turn to the right.

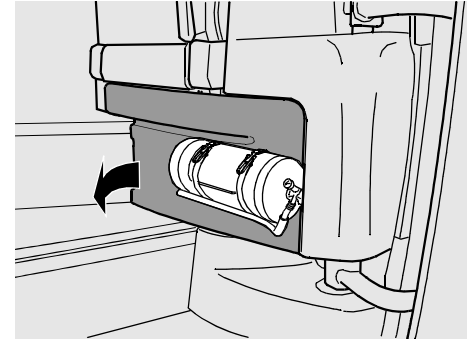

80001A

### FIRE EXTINGUISHER

The fire extinguisher is located by the entry, behind a shutter below the hostesses seat, and is provided with a pressure gauge used to check if the extinguisher is still in good condition. Ensure that the condition of the fire extinguisher is checked annually. If the extinguisher is used it must be refilled as soon as possible.



## SAFETY BELTS

The driver's and hostesses seat are provided with triple point anchorage safety belts.

The passenger seats are provided with triple anchorage point safety belts.



**It is your duty to ensure that the passengers use the safety belts properly!**

### Fastening

Insert the clip into its housing. When a clear click is heard, the belt is fastened. It is important for safety reasons that the belt fits snugly against the body.

The belt must not be crooked or twisted.

The hip belt must sit low (ie not above the stomach).

### Unfastening.

Push in the red knob on the housing. Ensure that inertia reel belts are rolled up without the belt being twisted.

### Locking inertia reel belts.

Normally inertia reel belts are free to

move.

The belt locks because of:

- Pulling the belt out too fast.
- Braking and accelerating, and when the vehicle tilts excessively to one side.
- On bends.

### Inspection

Check regularly that the belts are in good condition.

Locking function of inertia reel belts can be checked by giving them a short tug.

The belt should lock and not be able to be withdrawn.

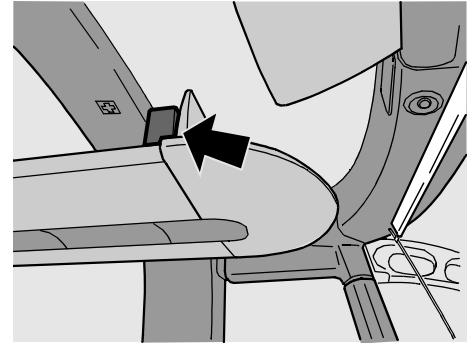

80004A

## FIRST AID KIT

The first aid kit is located above the driver on the luggage rack. Ensure that you always have a complete first aid kit (obligatory in some countries).



**Replace any of the contents as soon as they are used.**

## HAZARD WARNING LIGHTS

The hazard warning lights must be used if you are forced to stop or park in a way that obstructs or endangers other traffic.

The hazard warning lights are turned on with switch: Hazard warning lights page 32.



**Requirements for the use of warning lights vary from country to country.**

### Hazard warning triangle/warning lamp

Place the warning triangle or warning lamp (in the toolkit) at least 30 metres behind the vehicle in case of danger.

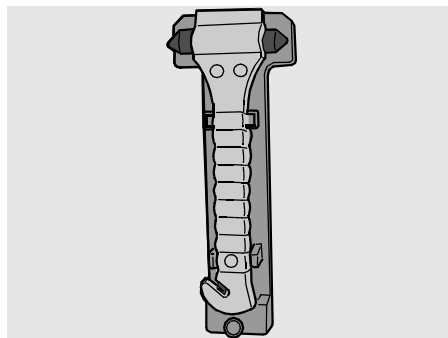

30034A

## EMERGENCY HAMMERS

In an emergency these hammers may be used to break glass or to cut through a safety belt.

The hammers are located on each window frame.

Break the seal and use the sharp point against the window glass, preferably not in the middle.



**Take account of the double glazing.**

## EMERGENCY PROCEDURES

Even a vehicle in good condition may be involved in an emergency, a breakdown or an accident. This almost inevitably leads to dangerous traffic situations, since the vehicle may not come to rest in a safe location.

The behaviour of the driver can contribute a great deal to damage limitation. Situations vary too much for a standard solution to be given, but there are common features and the following rules can generally be applied:

- First ensure your own safety then that of the passengers.



- Calm the passengers.
- Watch out for the other traffic.
- Be careful where you stand and walk.
- Watch out for the release of hazardous substances.
- Act quickly and decisively, but remain calm and avoid panic reactions.
- Prevent accidents and the escalation of accidents.
- Ensure that other road users are warned, for example by hazard warning lights, the vehicles own lighting, the hazard triangle or similar.
- Switch off the engine and turn off the master switch.
- Prepare fire extinguishers if appropriate, extinguish any fires which may break out.

Notify the emergency and rescue services if necessary.

Assist any injured persons.

# 4 MAINTENANCE

- GENERAL ..... 85
- MAINTENANCE CHECKLIST ..... 86
- DAILY CHECKS/MAINTENANCE 88
- WEEKLY CHECKS AND MAINTENANCE ..... 89
- WATER SYSTEM ..... 94
- FOR WINTER..... 95
- WHEN WINTER IS OVER..... 97
- EXTERIOR..... 97
- TOUCHING UP PAINTWORK..... 99
- INTERIOR MAINTENANCE..... 99

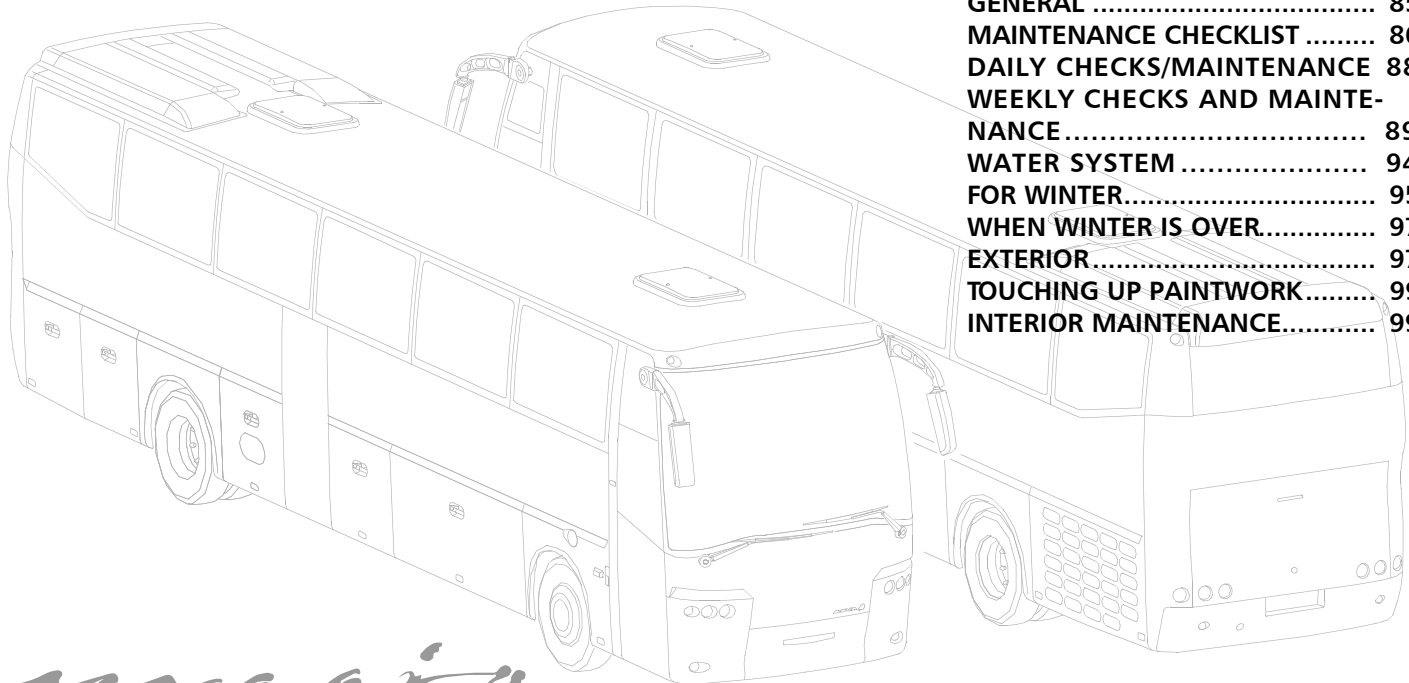

*magiq*





## GENERAL

The durability, safety, depreciation and reliability of the vehicle is to a large extent dependent on the way it is cared for and on the regular performance of the maintenance prescribed by BOVA.

The driver's driving style and his care of the vehicle have a direct influence on the vehicle's condition.

The driver can often give the workshop information which is valuable for good maintenance.

The vehicle should be maintained at the intervals given in the BOVA Magiq maintenance manual. However if the vehicle has to operate in dusty areas or under difficult conditions the frequency of maintenance should be increased.

The maintenance discussed under this heading refers to activities the driver himself can carry out.

A checklist is provided listing the points to be covered by the driver.



## MAINTENANCE CHECKLIST



The maintenance operations could be ticked off on a copy off this list.

	Daily	Weekly
<b>Engine compartment</b>		
• Check engine oil level*	<input type="checkbox"/>	<input type="checkbox"/>
• Check fluid level of the hydraulic system*		<input type="checkbox"/>
• Check coolant level*	<input type="checkbox"/>	<input type="checkbox"/>
• Check power steering fluid level*		<input type="checkbox"/>
• Check air filter*		<input type="checkbox"/>
• Check V-belts	<input type="checkbox"/>	<input type="checkbox"/>
<b>Underbody</b>		
• Drain water from air tanks*		<input type="checkbox"/>
• Check transmission, rear axle and engine for leaks		<input type="checkbox"/>
<b>Sides</b>		
• Check the wheelnuts visually		<input type="checkbox"/>
• Check tyre pressure		<input type="checkbox"/>
• Check tyres and rims for wear and damage	<input type="checkbox"/>	<input type="checkbox"/>
• Remove stones from the tread and from between the double tyres	<input type="checkbox"/>	<input type="checkbox"/>
• Check the closure of all side flaps	<input type="checkbox"/>	<input type="checkbox"/>
<b>Front</b>		
• Check windscreen and headlamp washer reservoirs*		<input type="checkbox"/>
• Check condition of windscreen wipers		<input type="checkbox"/>
• Check spare tyre pressure		<input type="checkbox"/>

	Daily	Weekly
<b>Interior</b>		
• Check seats for secure mounting and covers for damage and soiling		<input type="checkbox"/>
• Check Hydraulic Gearshift System fluid*		<input type="checkbox"/>
• Check clutch fluid*		<input type="checkbox"/>
• Check front box dust filter.		<input type="checkbox"/>
• Check seat belt security and reel mechanisms		<input type="checkbox"/>
• Check if first aid kit, emergency hammers and fire extinguisher(s) are present	<input type="checkbox"/>	<input type="checkbox"/>
• Check if doors, emergency exits and emergency valves open and close	<input type="checkbox"/>	<input type="checkbox"/>
• Check spares, jack, tools and hazard triangle are present	<input type="checkbox"/>	<input type="checkbox"/>
<b>Roof</b>		
• Check roof unit dust filters*		<input type="checkbox"/>
<b>Electrical system</b>		
• Check all exterior lights (parking lights, main and dipped beam, brake lights, fog lamps, reversing lights, clearance lights, registration plate lights, indicators and alarm lights)	<input type="checkbox"/>	<input type="checkbox"/>
• Check battery fluid levels*		<input type="checkbox"/>
• Check all interior lighting (main lights, dashboard, reading lamps and entry lighting)	<input type="checkbox"/>	<input type="checkbox"/>
• Check dashboard instruments and signal lamps for operation and correct signal before and after starting	<input type="checkbox"/>	<input type="checkbox"/>
• Check operation of windscreen wash/wipe and horn	<input type="checkbox"/>	<input type="checkbox"/>
<b>In freezing conditions</b>		
• Drain water tank, boiler, coffee machine and WC water supply	<input type="checkbox"/>	<input type="checkbox"/>
• Windscreen washer antifreeze in reservoir	<input type="checkbox"/>	<input type="checkbox"/>
• Antifreeze in chemical toilet	<input type="checkbox"/>	<input type="checkbox"/>

\*These operations are discussed in more detail in the following pages



## DAILY CHECKS/MAINTENANCE

Carry out daily checks and maintenance as follows: Maintenance checklist page 86.

Open the engine compartment see: Bonnet page 15.



Preferably, switch off the engine before opening the engine compartment.

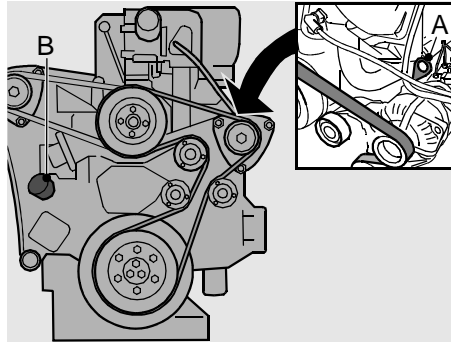

F50007

### Engine oil level

- Ensure the vehicle is standing on level ground.
- Turn off the engine and wait 5 minutes minimum.
- Remove dipstick A from its housing
- Clean the dipstick with a lint-free cloth

- Insert the dipstick in its housing and wait a few seconds
- Remove the dipstick again and read the level: it should always be between the two marks.
- Add oil as necessary via the opening B.

Always use the correct oil.  
Avoid overfilling.



Oil specification is in the technical data section.

The difference between full and empty oil levels is around 8 litres.

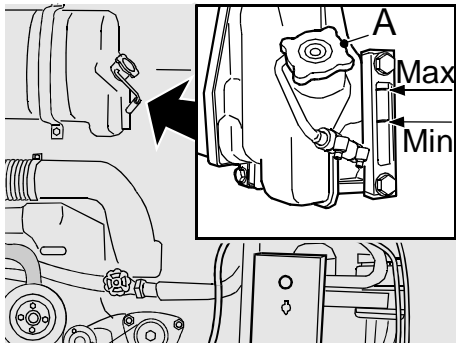

50032A

### Coolant level

Check coolant level when the engine is cold.  
If coolant level is below the minimum, checks for leaks must be carried out.



If the coolant is warm the cooling system is under pressure. In that case cover the filler cap with a thick cloth and remove it slowly and gradually, allowing pressure to escape. Then remove it completely.



Engine coolant contains harmful substances, so avoid skin contact.



To avoid damage to the engine block when adding cold coolant to a warm engine, add it slowly while the engine is running.

Remove filler cap A from the reservoir. Fill the reservoir to the maximum. See "Technical data" for the specification for coolant.

Bring the engine up to working temperature.  
Switch off the engine and check the coolant level.

## WEEKLY CHECKS AND MAINTENANCE

Carry out the following weekly checks and maintenance: Maintenance checklist page 86.



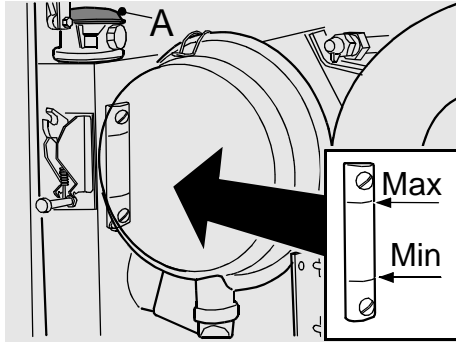

F50009

### Hydraulic fluid

Both the ventilator and the air conditioning compressor drives make use of the same reservoir of hydraulic fluid.

Check that the fluid level is between the two marks.

Fill as required via opening A

For the specification for hydraulic fluid see "Technical data".

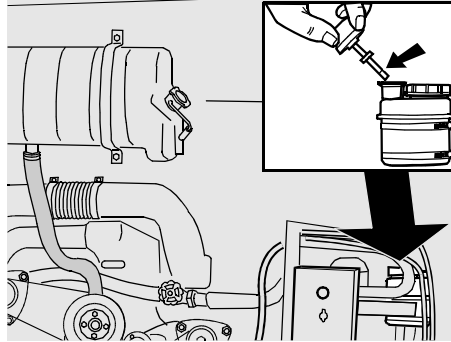

50033A

### Power steering fluid

Check, with the engine stopped, that the fluid reaches around 2 cm above the upper marking on the dipstick. Add fluid as necessary.

Start the engine (the engine can not be started when the bonnet is open). The fluid should reach the upper marking on the dipstick when the engine is running and the vehicle is stationary.

For power steering fluid specification, see "Technical data".

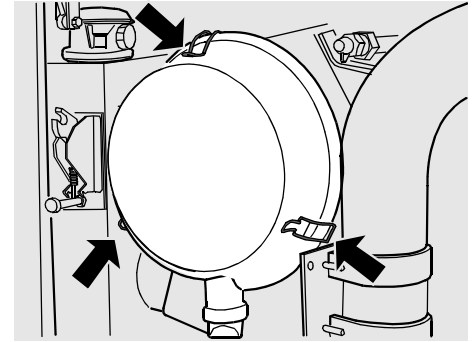

F50011

### Air filter

Check the air filter for soiling and damage.

If damaged it must be replaced immediately.

If the air filter is dirty it may be cleaned by blowing from the inside with compressed air (maximum pressure 5 bar).

Clean the filter housing before replacing the filter.

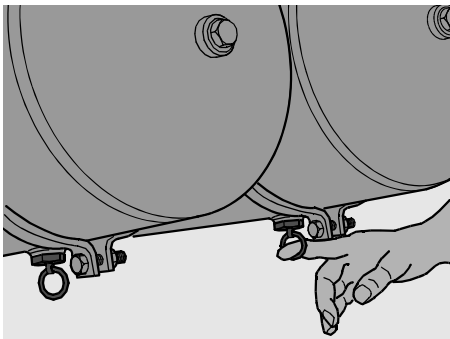

70001A

### Brake system air dryer

Drain water out of the air tanks by pulling on the rings. The air tanks are best reached via the spoiler flap. If more water is regularly drained off than has been usual, the air dryer filter element must be replaced (consult a BOVA workshop).

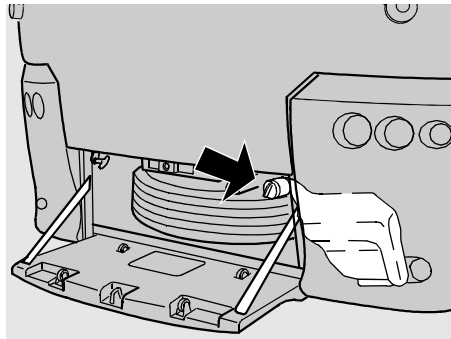

20002A

### Screenwash reservoir

Check the screenwash reservoir and fill if necessary. Add screen-clean in summer. Add anti-freeze screen clean in winter.

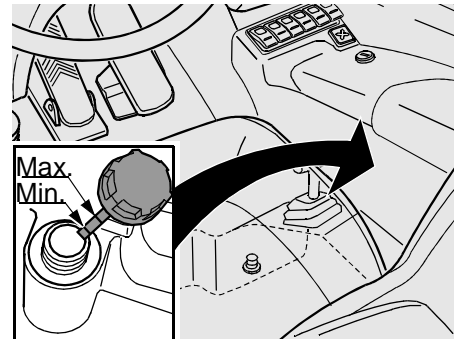

50015A

### Hydraulic Gearshift fluid

Check the fluid level in the HGS reservoir when the engine is cold and at a normal outside temperature (around 20 °C). The fluid should be between the marks. Add fluid as necessary. For hydraulic fluid specifications see "Technical specifications".

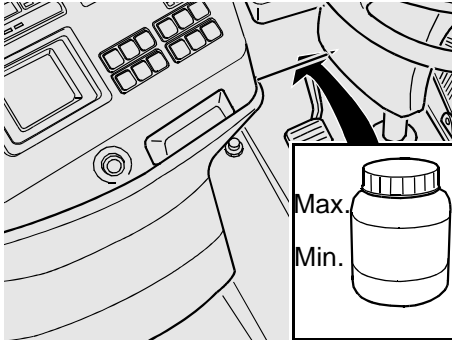

50014A

### Clutch fluid

Check the fluid level in the clutch fluid reservoir.  
The fluid level should be between the marks.  
Fill as necessary.  
For clutch fluid specification see "Technical data".

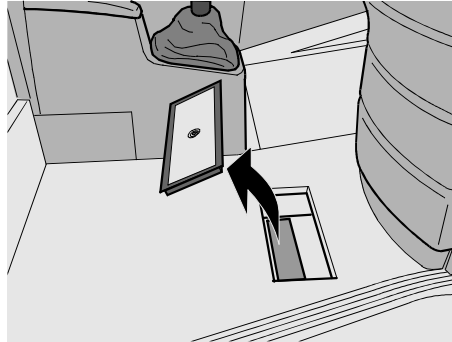

10021A

### Front box dust filter

The dust filter in the front box is accessible via the hatch in the floor near the front entryway.  
Unlock the hatch by loosening the bolt a full turn (5mm Allen key).  
Remove the hatch.  
Remove the filter housing cover (2 x 4mm bolts).  
Remove the filter.  
Clean or if necessary replace the filter.  
Clean the filter housing before replacing the filter.

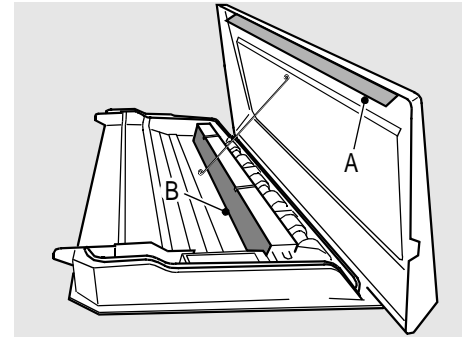

10003A

### Roof unit dust filters

The dust filters are located in the roof units.



**Except in case of emergency, it is not permitted to climb onto the roof by means of the roof hatches.**

Clean the area around the roof units.  
Open the roof units (8 mm Allen key).  
Remove leaves, twigs etc. from filter  
A and clean the filter.  
Clean the filter housing.  
Check and if necessary replace filter B.  
Check that filter A is correctly posi-  
tioned when closing each roof unit.  
Close and lock the roof units.  
(8 mm allen key)

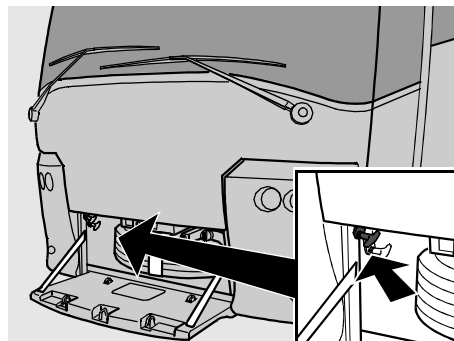

10023A

### Batteries

The batteries are located front right,  
behind a closeable flap.  
The flap may be unlocked by pulling  
the knob located behind the spoiler  
flap.

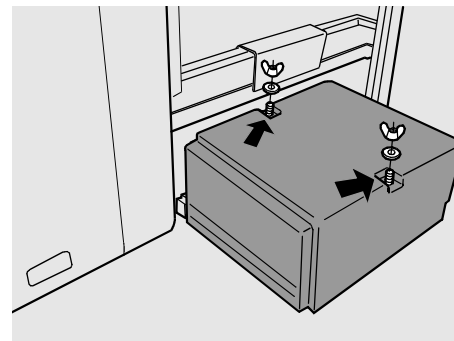

6002A

The battery cover can be removed by  
undoing the two wing nuts.



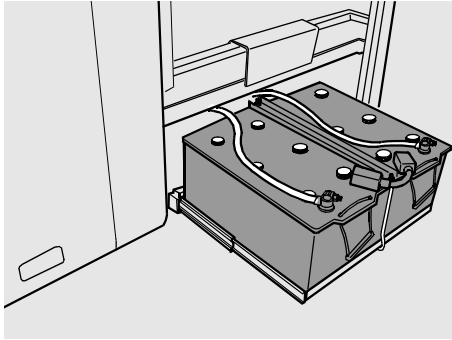

60001A

Check electrolyte level: it must be around 5 mm above the plates. Refill as necessary with distilled water.



**Battery acid is an aggressive fluid. Rinse with plenty of water if it contacts clothing, eyes or skin.**

Check that the battery contacts and clamps are clean and well-greased. Grease them if necessary with acid-free vaseline.

Don't forget to replace the battery carriage securing pins after these checks.

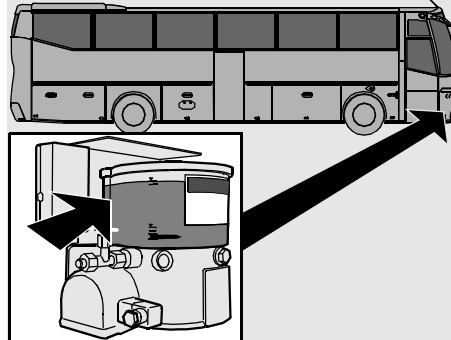

80005A

### Central greasing

If central greasing is installed, check the grease level in the reservoir. Fill as necessary.

## WATER SYSTEM



The owner of the vehicle is at all times responsible for the quality of the water used in the vehicle.

In order to reduce to a minimum the development of legionella bacteria, the following issues need to be considered:

### Main water tank:

- Flush once a month with a disinfectant.

### Extra (drinking-) water tank

- Inspect once a fortnight or inspect with every filling if the tank is not filled through the normal couplings, but through the inspection panel.
- In case of scale formation in the tank, it should be cleaned according to the aforementioned method.

### Water conduits

As the hosepipes are rinsed out while cleaning the tank, a visual inspection of the hosepipes while filling the water tank should be sufficient.

## Connected devices

- The temperature of the water heater should be adjusted to the maximum temperature ( $\pm 85$  °C). Along with cleaning the tanks and the pipes, this will minimize the risk of infection.



Connecting a washing installation to the main water tank increases the risk of legionella infection.

## FOR WINTER

### Check anti-freeze content

Check the anti-freeze content of the coolant.  
If anti-freeze has not been added already, fill the cooling system with anti-freeze.



To avoid damage to the engine block when adding cold coolant to a warm engine, add it slowly while the engine is running.

Only use coolant, or if appropriate, anti-freeze, which satisfies BOVA specifications: see "Technical data". No variation is permissible because of the aluminium radiator fitted.

Follow the manufacturer's instructions for the correct composition of coolant when adding anti-freeze.

### Screenwash/headlamp wash reservoir

Add winter screenwash.

### Air conditioning

We advise that the side flap of the

condenser compartment should have the winter cover installed to protect the climate box against salt and road grime.

It is not possible to switch on the air conditioning system when the winter cover is in place.

Run the air conditioning system compressor regularly (around once a month) for several minutes to allow oil to be pumped around the system, preventing the seals from drying out.



Remove the condenser's winter cover during this operation.

### Fuel

During the winter months the fuel suppliers often use additives to prevent paraffin deposits, which cause blockages.

In extremely low temperatures, or when no so-called winter fuel is available, a maximum of 20% kerosine may be added, **where this is permitted by law.**

Where that is not allowed by law, then a maximum of 20% lead free petrol may be added.

Where it is legally permitted, up to 0.5% methylated spirit may be added

to prevent ice formation. Fuel additives to prevent paraffin deposits have only a preventative effect. They are not suitable for dissolving the paraffin.



**Ensure that a spare fuel filter is available so that the filter can be replaced in the event of blockages (also those caused by paraffin deposits), See: Replacing fuel filters page 107.**

### **Batteries**

The demands placed on batteries are much higher in the winter than in the summer, since light, windscreen wipers etc are used more. The battery capacity also falls in low temperatures.

A poorly charged battery may freeze if it is extremely cold. Check the charging status of batteries regularly and grease the terminals with acid-free vaseline.

### **Locks**

Use special lock oil (teflon spray oil). Avoid the use of ice-melting sprays as these interfere with the proper operation of the lock.

### **Door and flap rubbers**

To prevent freezing the various rubber seals should be rubbed with talc.

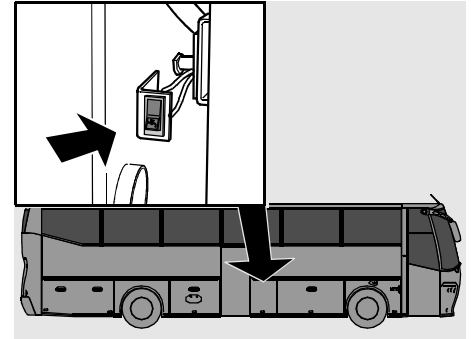

70005A

### **Kitchen and toilet water system.**

Operating this switch disables the water reservoir empty alarm. The water can subsequently be pumped out of the tank by operating the tap in the vehicle.



Reset the switch after emptying the tank so that the alarm functions, preventing the pump from running dry.



Make sure that all reservoirs and pipes are drained to prevent freezing.

## WHEN WINTER IS OVER.

### Cooling system

The anti-freeze mixture may be left in the system during the summer.



If the vehicle is used in regions where the temperature never falls below 0°C, antifreeze should be nevertheless be added to the coolant, as the coolant temperature in the climate control system can fall below 0°C.

### Screenwash/headlamp wash reservoir

It is advisable to add a cleaning agent to the water.

### Air conditioning

Remove the winter cover from the condenser compartment side flap.

## EXTERIOR

### Washing

Wash the vehicle as soon as it is dirty in winter as salt and dampness easily cause corrosion.

Remove bird droppings as soon as possible from the paintwork! Bird droppings contain substances which attack and discolour paintwork. The discolouration can not be polished away.



Always wash the vehicle in a suitable place.

You can wash the vehicle as follows:



## Hand washing

- Carefully hose off the soiling from the underside of the vehicle (wheel arches, around mudflaps etc.).
- Hose down the whole vehicle to loosen the dirt. Avoid spraying directly into locks.
- Wash the vehicle using a sponge, with or without a cleaning agent. Use lukewarm water for preference, but avoid hot water.
- Dry the vehicle with a clean, soft chamois.

## Washing with a high pressure jet washer.

Take care that the spray head of the jet washer does not come closer than 30 cm from the coachwork. Also, avoid spraying into or near the locks of the various hatches and doors and the engine compartment.

## Cleaning in a vehicle washing machine.

The vehicle can be washed quickly and simply in a vehicle washing machine. Bear in mind however that the vehicle washing machine cannot clean the vehicle as carefully and effectively as

you can with a sponge and water. The car-wash brushes cannot reach into all areas. Before entering the vehicle washing machine, ensure that any extra equipment is properly secured, or it may be pulled loose by the brushes. Only wash the vehicle in a vehicle washing machine with clean brushes.



**It is not recommended to use a vehicle washing machine for the first few months as the paint layers may not have sufficiently hardened.**



**Depending on the type of car wash it may be necessary to fold in or remove the mirrors, see: Mirrors page 73.**

## Cleaning agents

Car shampoo, or 5 - 10 cl ordinary washing-up liquid to 10 litres of water.

Spotting on aluminium may be removed with car polish.

**Never** use polishing paste or steel wool.

## Waxing and polishing

You should wax and polish the vehicle if you find that the paint has lost its gloss and normal washing doesn't restore the original gloss. Normally the vehicle exterior will need polishing only after a year. You may apply wax before then. Wash and dry the vehicle well before polishing or waxing. Remove asphalt and tar spots with turpentine. Stubborn marks may be removed with a fine car paint polish. There are many brands of polymer wash materials on the market. These are easy to work with and give a hard and very glossy surface which protects the paint against oxidation, dirt and dulling.

## TOUCHING UP PAINTWORK

### General

Paint damage on metal parts must be dealt with without delay to prevent rust formation.

It is advisable to check the paintwork regularly, perhaps after each wash, to touch up any possible damage.

Small spots and scratches can be touched up with a paintbrush.

Larger areas of paint damage require special equipment and expertise. It may be advisable to have more major damage repaired by a specialist workshop.

### Minor scratches and stone damage

If the chipping caused by stones has not penetrated to the metal, and undamaged paint is still present, you may paint directly over the spot, after polishing to remove dirt.

If the chipping has penetrated to the metal you must proceed as follows.

- Sand the damage area down to the metal and remove sharp paint edges with a sharp knife.
- Use a rust removal agent on the metal, wait for several minutes

and then wash well with water. Then rub dry. (this treatment is not needed on plastic substrates).

- Stir the primer well and apply it.
- When the primer has dried apply the top coat with a brush.

## INTERIOR MAINTENANCE

### General

Remove soiling as soon as possible before it has dried in.

Soiling should be dissolved away, rather than rubbed, scraped or removed with a hard brush. Always work from the edge of the soiling towards the middle.

### Cleaning upholstery

The fabric upholstery of the seats can generally be cleaned with soap and water or detergent solution.

With difficult stains like oil, ice-cream and shoe-polish, a special cleaning agent may be used. Follow the cleaning agent manufacturer's instructions.

Use solvent cleaners sparingly. Excessive use of solvents may damage the foam plastic filling of the seats.



### **Cleaning curtains and seat covers**

Curtains and seat covers can normally be washed in cold water.

If they are soiled they can be washed at 30 °C.

Bleach should not be used.

Use of washing powders may cause discolouration.

To keep colours uniform all curtains or covers should be washed together. Brushing covers is not recommended.

### **Cleaning plastic**

Plastic parts should be cleaned with a lukewarm solution of synthetic cleaning agent.



**Avoid the use of trichloroethylene, petrol and similar materials on plastics.**

### **Cleaning carpets**

Soak up as much as possible with clean cloths.

Vacuum around the affected area to avoid spread.

Dampen the affected areas with textile cleaning agent on a clean cloth.

Soak up the cleaning agent with a dry cotton wad. Repeat the process until the soiling is gone.

# 5 RUNNING REPAIRS

- GENERAL ..... 103
- ON-BOARD TOOL KIT. .... 104
- ENGINE COMPARTMENT..... 105
- MAGIQAIR-SYSTEM..... 109
- ABS SYSTEM ..... 109
- AIR SUSPENSION LEAKS..... 109
- WHEELS AND TYRES ..... 110
- REPLACING BULBS ..... 112
- REPLACING FUSES. .... 114
- JUMP STARTING..... 116
- TOWING ..... 116
- ITS BOVA..... 120

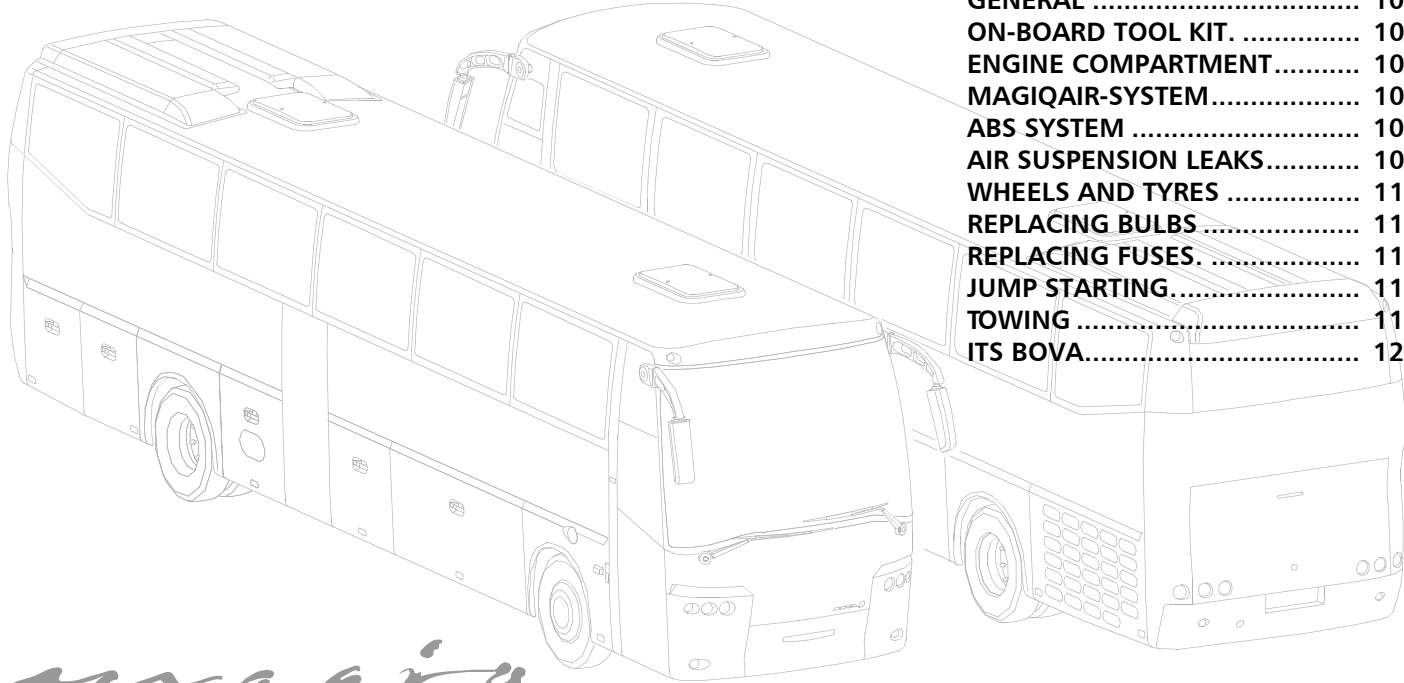

*magiq*





## GENERAL

Even if your care of the vehicle is exemplary, problems may still arise, such as a flat tyre, blown bulb or similar, which you will have to repair to continue the journey.

### Safety



**Before attempting to carry out repairs you must first ensure your own safety and that of the passengers. Stop the vehicle in a safe place and if necessary have the passengers assemble in a safe place near the vehicle.**

### Cleanliness

A clean working environment is of great importance when carrying out repairs, to prevent giving rise to the need for further repairs to damage caused by unnecessary contamination.

A clean and tidy work environment also improves safety. Also, you should leave the working area in the same condition as you found it.

## ON-BOARD TOOL KIT.

The vehicle is equipped with an on-board tool kit including:

	number		
Tool kit	1	wheel key	1
4 mm drift	1	jack and foot	1
tommy bar	1	jackrod	1
wheelnut spanner	1	tyre inflation hose	1
open ended spanner 14-15	1	inspection lamp with plug	1
ring spanner 17-19	1	emergency lamp	1
open-end spanner 17-19	1	torch	1
ring/open-end spanner 18	1	hazard warning triangle	1
ring/open-end spanner 32	1	towing eye assembly	1
Allen key 8 mm	1	4 amp pull out fuse	5
5 mm allen key	1	5 amp pull out fuse	1
cross-headed screwdriver	1	7.5 amp pull out fuse	1
150 mm screwdriver	1	15 amp pull out fuse	1
75 mm screwdriver	1	20 amp pull out fuse	1
bench hammer, 400 g	1	80 amp pull out fuse	2
250 mm spanner	1	window handle	1
combination pliers	1		
water pump pliers	1	The on-board tool kit is located in the extra storage compartment to the right behind the rear axle.	
10 compartment tool roll	1		

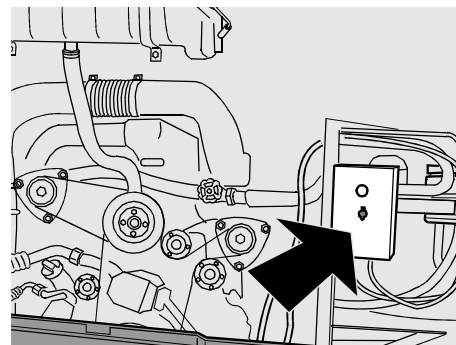

50034A

### Inspection lamp connection

The 24 volt inspection lamp can be connected to two sockets in the vehicle.

#### Engine compartment:

The inspection lamp, without its plug, may be connected in the engine compartment as shown in the illustration above.

#### Cigar lighter

To connect the inspection lamp to the cigar lighter socket, fit the lamp's adaptor plug.

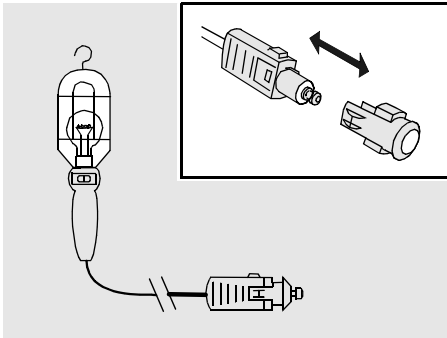

F30095

### Plug

Fit the adaptor plug to the inspection lamp plug for use in the cigar lighter as illustrated.

## ENGINE COMPARTMENT

### Replacing v-belts



Always fit v-belts of the same design.



Where two v-belts are used together, both must be replaced together.

- Release locknut (A) from stud.
- Release securing bolt (B) from water pump stud.
- Release securing bolts (C) and (D) from the dynamo.
- Release locknut (E) from adjuster (F)
- Turn the adjuster (F) so that the dynamo leans in the direction of the engine block.
- The V-belts may now be replaced.

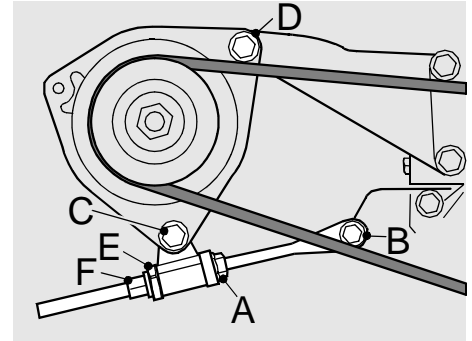

F50012

- Inspect the pulleys for damage, rust and contamination with grease.
- Fit and tension the new V-belts (see adjusting V-belt tension).



Check the adjustment of the new v-belts after the first 50 km and have the tension checked as soon as possible by a BOVA garage.



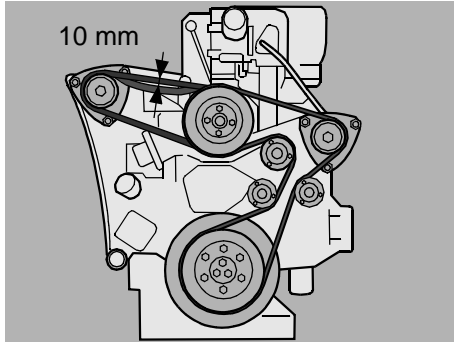

F50013

### Adjusting v-belt tension

Remove fixing bolts and locknuts (see replacing v-belts).

Position the dynamo, by turning the adjuster until the correct V-belt tension is achieved.

A correctly tensioned V-belt can be deflected around 10 mm by light pressure at a point between the dynamo and water pump. Replace all nuts and bolts.

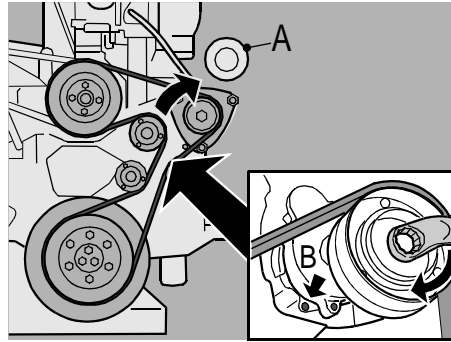

F50014

### Replacing multi-V belt



**Always fit a multi-V belt of the same specification.**

- Disconnect the battery earth lead.
- Remove cover cap A and fit a suitable spanner to the automatic belt tensioning mechanism.
- Slacken the multi-V belt by turning the spanner against the belt tensioner spring pressure.
- Place a drift at position B so that the spring tensioner is locked and remove the V-belt from the pulleys.
- Inspect the pulleys for damage, rust and grease deposits.

- Fit a new V-belt.
  - Remove the drift and cautiously allow the automatic belt tensioner to take up tension against the new V-belt
  - Check that the multi-V belt sits in all pulley grooves.
  - Replace the cover cap A.
- Reconnect the battery earth cable.

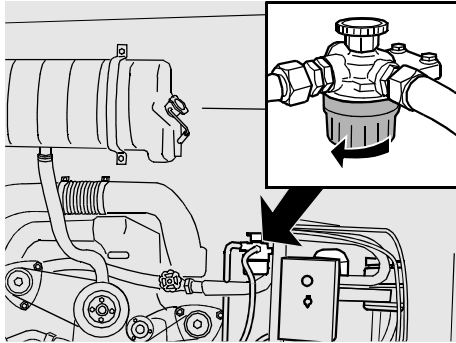

50036A

## Replacing fuel filters



**Diesel fuel is flammable and should not be exposed to open flame or other heat sources such as a hot engine. Catch any leakage in a suitable container.**

## Cleaning coarse fuel filter

The coarse fuel filter may require cleaning, for example because of wax deposits.

- Unscrew the lower part of the filter housing and clean the filter.
- Check the sealing rubber and replace, if necessary.
- Anoint the sealing rubber sparingly with engine oil.
- Reassemble the filter and filter housing in the reverse order (torque 10 Nm).
- Check the fuel system for leaks with the engine running.

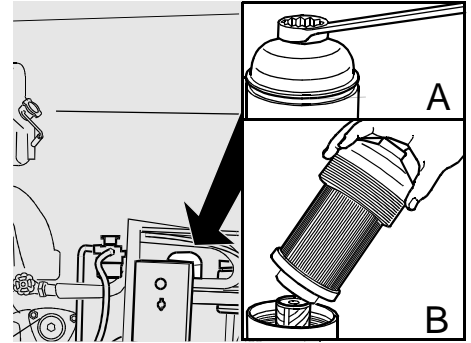

50035A

## Replacing fine fuel filter

The fuel filter is located to the right of the engine adjacent to the power steering reservoir.

Replace the filter by the following procedure:

- Remove the filter by rotating the filter housing cap to the left, whereupon the filter element can be replaced.
- Check the sealing rubber and replace if necessary.
- Smear the sealing ring sparingly with oil.
- Place a new filter element in the cap and replace the cap, together with the filter element, in the filter housing.



- Screw the new filter home (torque 25 Nm).
- Bleed the fuel system.
- Check for leaks with the engine running.

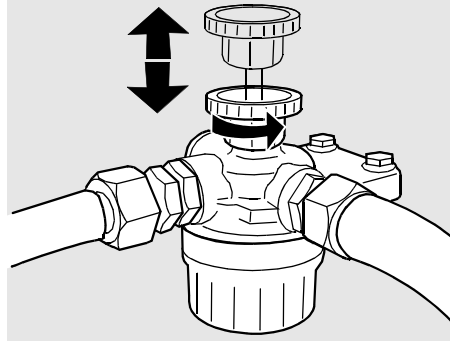

F50016

### Bleeding fuel system.



**Diesel fuel is flammable and should not be exposed to open flame or other heat sources such as a hot engine. Catch any leakage in a suitable container.**

Turn the bleed pump on the filter housing to the left so that the hand pump can be operated.

Pump, with the hand pump, until the filter housing is filled with fuel. Start the engine and lock the hand pump.

### Starting after emptying the fuel tank



**Avoid emptying the fuel tank. The starting procedure described here is an emergency measure. The engine will start only after prolonged operation of the starter motor. Failure to follow the procedure below may lead to damage to the starter motor.**

- Bleed the fuel system.
- Operate the starter continuously until the engine starts. The maximum operating period for the starter is 1 minute. If the engine fails to start after this time, allow the starter motor to cool for 2 minutes. Operate the starter motor for a maximum of one minute. If the engine fails to start during this minute, allow the starter motor to cool for a minimum of 30 minutes, before repeating the starting cycle described above.
- The engine will run unevenly for some time after starting.

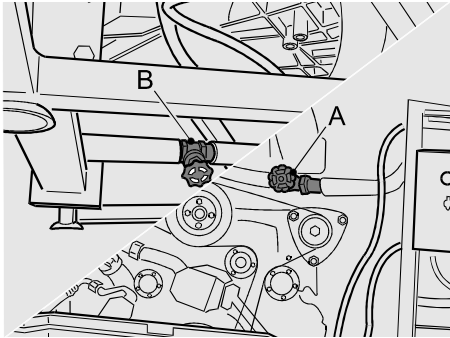

50038A

## MAGIQAIR-SYSTEM

If there is a leakage in the magiqair-system it is possible to cut off the magiqair circuit from the engine cooling circuit by closing tap (A) in the engine compartment and tap (B) at the left bottom side of the engine.



Check the coolant level and top up if necessary.



You can drive on but heating and/or airconditioning are not functioning.

## ABS SYSTEM

Illumination of the red warning light at speeds above about 7 km/h indicates a fault in the ABS system. Check the ABS system fuses. If the fault is not cleared up by replacing fuses, the journey may continue since only the ABS system is inoperative and the normal braking function is preserved.



It is now possible that the wheels may lock on powerful braking.

Have the ABS system repaired by an authorised workshop.

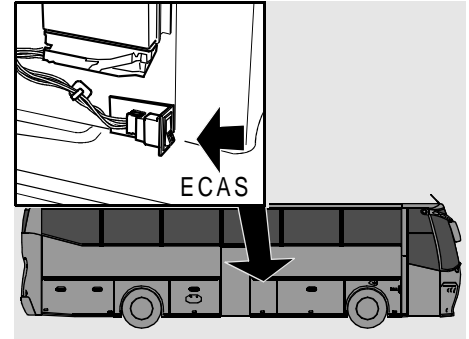

70006A

## AIR SUSPENSION LEAKS

If a spring bellows develops a fault the ECAS symbol will light up on the display. Switch the axle in question to "kneel" and then switch off the ECAS system. The switch is in the fuse box next to the toilet.



The journey may continue, at a reduced speed.

The fault must be repaired as soon as possible.

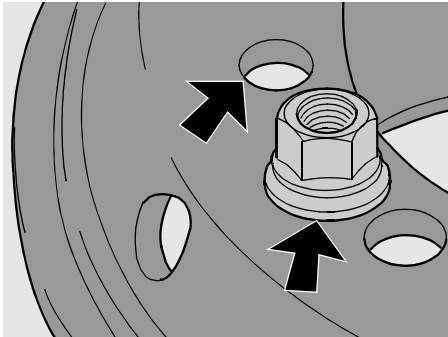

50022A

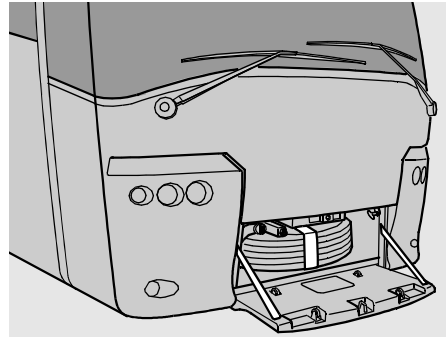

10001A

## WHEELS AND TYRES

### General

BOVA fit their coaches with the so-called wheel hub centering system. Characteristics of wheel hub centering:

- Wheels with cylindrical bolt apertures.
- Wheel nuts with loose, plain pressure rings which can not be removed.



**Use only the appropriate wheel hub centering wheels and wheelnuts.**

### Spare wheel

The spare wheel is located behind the spoiler flap. The spoiler flap is opened by pulling on the handle next to the steering column, see: Spoiler flap handle page 26.



**Check first that the spare wheel is in a usable condition and inflate to the correct pressure, see: Tyre inflation page 112.**

Remove the spare wheel by taking off the clamp and pulling a draw band through the wheel so that it can be pulled out.

### Wheel replacement

- Park the vehicle on a hard, level road surface in a safe position.
- Chock the wheels to prevent the vehicle rolling.
- If necessary switch on the hazard warning lights and place the hazard warning triangle at least 30 m behind the vehicle.
- Clean the wheel nuts and apply a drop of oil to the thread.
- Loosen the wheel nuts one half turn.
- Place the jack next to the wheel in question (see: Jacking points page 111 ) and jack it up until the wheel is clear of the ground.



**Read the documentation supplied before using the jack.**

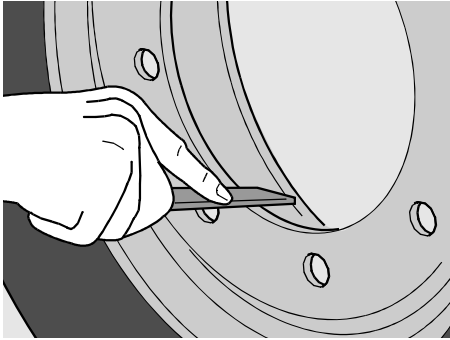

50023A

- Remove the wheel nuts and take off the wheel.
- Before fitting, clean the fitting face of the wheel hub and the inside of the spare wheel carefully, removing any burrs and paint residue. Lightly smear the fitting face with grease.

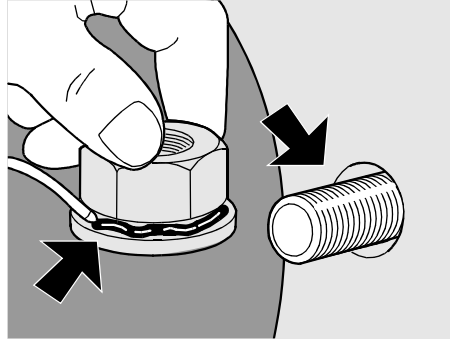

50024A

- Clean the wheel studs and apply oil to the threads.
- Apply a drop of oil between the pressure ring and the wheel nut.
- Offer up the wheel and turn the nuts up tight.
- Remove the jack and tighten the nuts sequentially and diagonally to the prescribed torque (615 Nm).



**Retighten after 100 km.**

Stow the spare wheel and the tools.  
Don't forget the warning triangle.

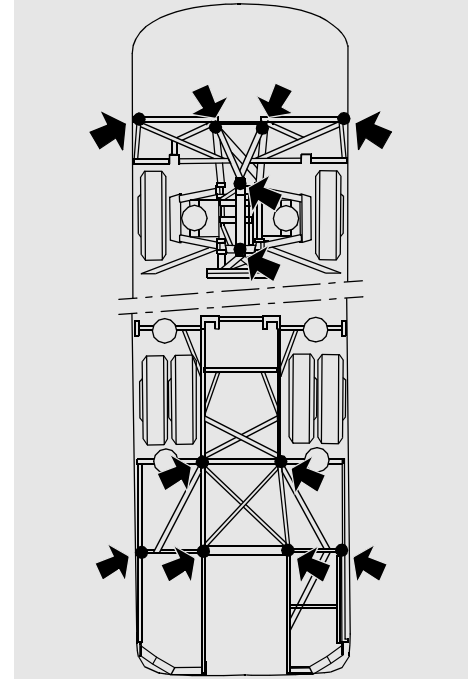

10016A

### Jacking points

The jacking points detailed above have been provided to jack the vehicle up.



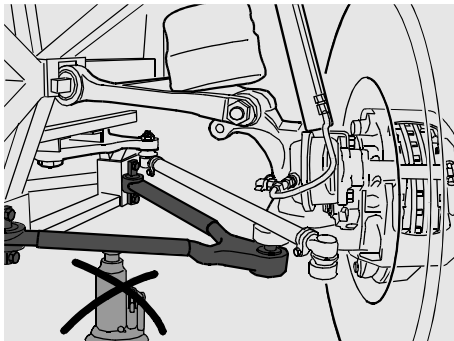

10015A



**Never put a jack under the suspension triangle of the front axle or under the differential housing, or under the body of the rear axle.**



**Always use stands when working under a jacked up vehicle.**



**Read the documentation supplied before using the jack.**

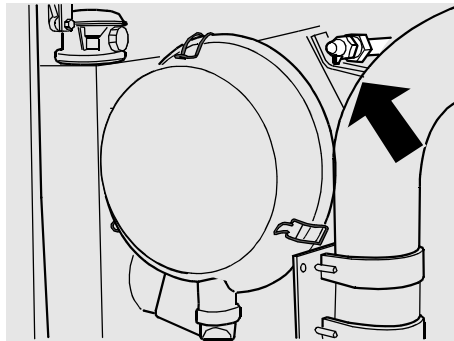

50037A

### **Tyre inflation**

Remove the cap from the emergency inflation connection. Attach the inflation hose. Inflate the tyres. The engine must be running but the stored pressure must not be at maximum, otherwise the compressor will not deliver air.



**The pressure can be lowered by operating the brake pedal.**

For correct tyre pressures see: Tyre pressures page 131.

## **REPLACING BULBS**

### **General**

Never touch the glass of bulbs with the fingers. Traces of grease, oil or other contaminants will adhere to the glass, shortening the life of the bulb. When the contaminants become damp they will attack the reflector.



**Use the packaging to protect the glass from your fingers.**



**Check the headlight alignment whenever the headlamp bulbs are replaced.**

For a complete list of the lamps and there specifications see: Lighting page 136.

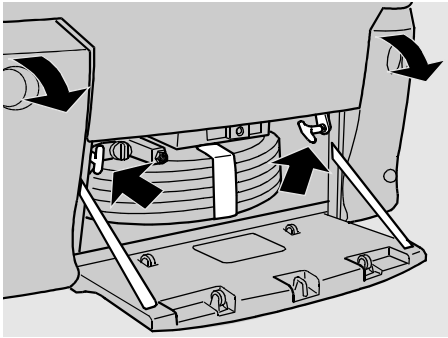

10004A

### Replacing headlamps

Open the spoiler flap handle (see: Spoiler flap handle page 26) and open the relevant headlamp space by pulling on the handle.

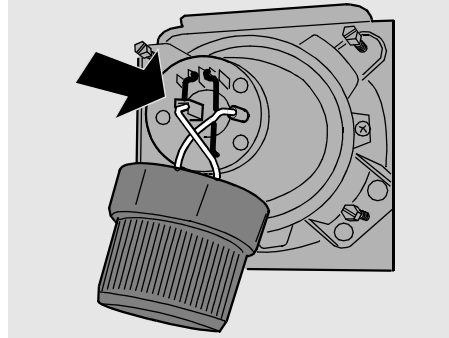

20016A

Remove the protective cover on the light by turning it to the left. Pull out the light plug. Unhook the spring. Replace the bulb.



**Make sure that the lamp engages in the recess in the reflector.**

### Headlights driver's side.

The bulbs on the driver's side are replaced in the same way.

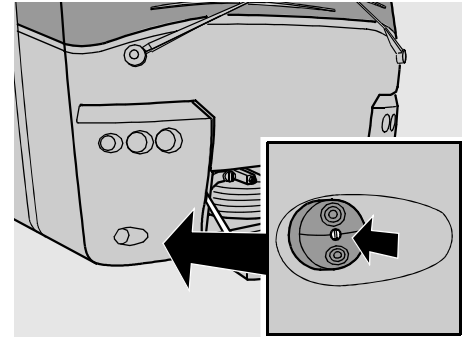

20004A

### Front indicator lamps

Remove the plastic covering cap from the indicator lamp. The bulb can now be replaced.



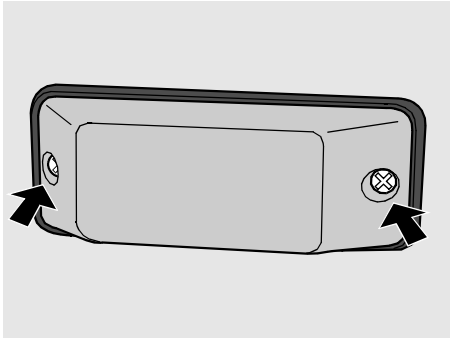

20005A

### Side indicator lamps

Remove the plastic covering cap of the side indicators (2 x crosshead screws).

The bulb can now be replaced

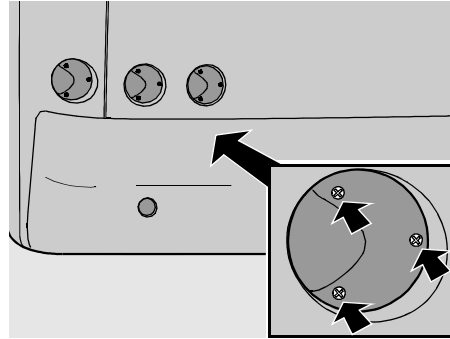

20006A

### Rear lights

Remove the plastic cover cap from the lamp (3 x cross head screws).  
The bulb can now be replaced.

## REPLACING FUSES.

### General

If an electrical component fails to operate this may be because a fuse has burned out due to temporary overload.

The vehicle's fuses are in three locations.

- One fuse box is at the front left above the batteries.
- One fuse box is behind the central luggage flap on the right of the vehicle.
- One fuse box is to the right rear, in the extra luggage space beside the engine.

Look in the fuse list supplied to see which fuse is to be checked.

The fuse lists are located in the electro boxes.

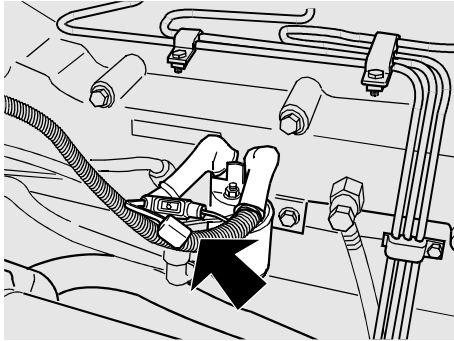

50027A

### Pre-heater relay

The 5 amp fuse for the pre-heater warning lamp is near the pre-heater relay. The pre-heater relay is fixed to the inlet manifold on the right hand side of the engine.

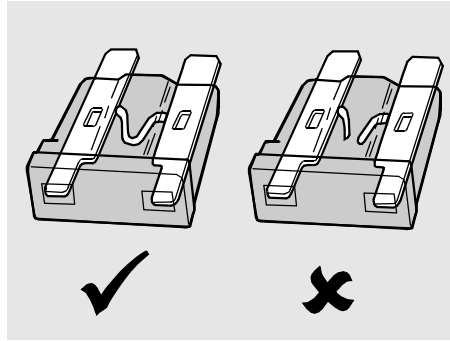

70002A

Pull the fuse straight out and look inside to see if the bent wire is burned out.

Replace if necessary with a new fuse of the same colour code and capacity. The amperage is stated on the fuse.



**Never replace a blown fuse with one of a higher capacity.**

If fuses in the same location burn out repeatedly, there is a failure in the electrical installation and the vehicle must be taken to a workshop for inspection.

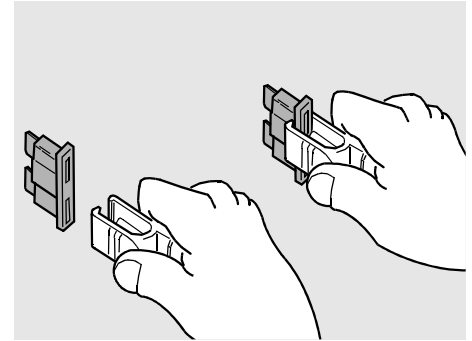

70003A

"Pincers" are provided for the easy changing of the fusing.



**Spare fuses are supplied with the tool-kit.**



**Don't forget to replace the pincers after use.**

## JUMP STARTING.

If the vehicle is started with the aid of separate batteries (24V approx) or with the help of another vehicle with its engine running (28V approx) the battery cables must not be removed.



**Never use quick starter equipment to start the vehicle as this may damage the vehicle electronics.**



**Avoid generating sparks as these may lead to the batteries exploding.**



**Prevent the two vehicles touching each other.**

Attach the starter cable first to the positive (+) terminal clamp and then to the negative (-) clamp. When disconnecting, remove the cable from the negative (-) terminal first and then from the positive terminal (+). In the event that the batteries are completely discharged and the engine starts, it is important not to remove the starter cables immediately. To prevent damage to the electrical system through voltage peaks the engine must run for at least 3 minutes before the starter cables are removed.

## TOWING



**A vehicle with passengers inside must not be towed.**

### Safety

Always use a towing clevis, except in an emergency. Keep the speed to a maximum of 40 km/h in these circumstances.

Driving speed must always be matched to the conditions.



**It is not permissible to remove the half axles when towing. Brake operation can not be guaranteed unless this advice is followed.**

The drive shafts must always be uncoupled from the differential when towing over long distances to prevent damage to the gear box

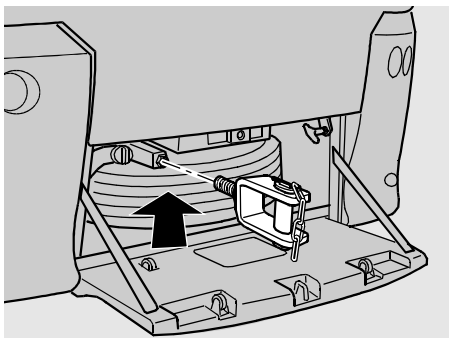

10005A

### Fitting towing eye

A towing eye is supplied with each coach.

The towing eye is located with the on-board tool kit in the luggage compartment to the right behind the rear wheel.

The towing eye may be screwed into a socket behind the spoiler flap, or in the rear bumper, above the exhaust.



**Screw the towing eye in as far as possible.**

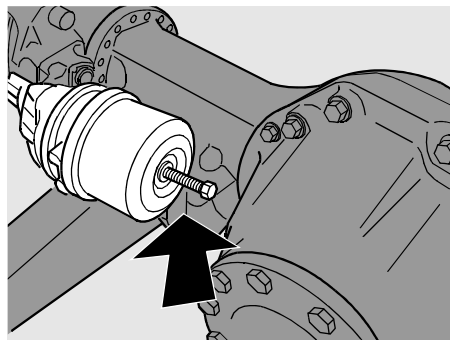

50026A

### Releasing the parking brake

Start the engine and bring the brake system up to pressure.

If it is not possible to start the engine, the parking brake can be freed by two different methods.

- Place chocks in front of or behind the wheels and turn the bolts of both brake spring cylinders as far as possible to the left with the aid of a 24 mm spanner. The coach can now be towed.

Restore the operation of the brake spring cylinders as quickly as possible, by turning the bolts as far as possible to the right setting them with a torque of 40-50 Nm.

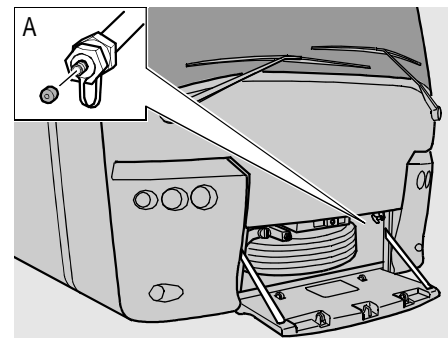

10019A

- The second method of freeing the parking brake makes use of the emergency air connection, to which an air hose can be connected to import air from another source.



**To free the parking brake the system must be pressurised to at least 6 bar.**



**Maximum pressure in the parking brake may not exceed 11 bar.**



**!** If the engine is not running the vehicle's steering will be heavy due to the lack of power steering.

**!** Turn on hazard warning lights before towing and attach an "on tow" sign to the towed vehicle.

### **Towing with a damaged differential**

Hoist the rear of the coach and lock the steering wheel.

### **Towing**

**!** Vehicles with automatic transmission can not be towed.

If the vehicle must be towed to start the engine, the ignition key must be turned to position I. When towing it may happen that the batteries are too low to allow the master switch to be closed by the dashboard switch.

To prevent damage to the dynamos and regulator, master switch relay contacts 31 and 31a must be temporarily connected together (see drawing).

The master switch relay is located behind the front fuse box above the batteries.

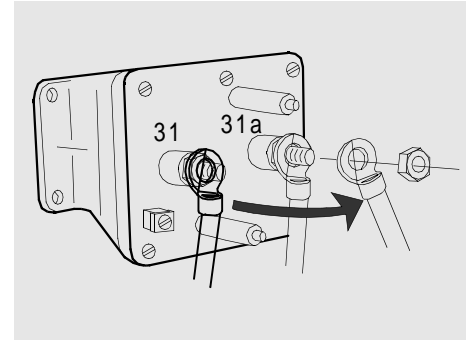

F30099

- Remove the battery earth clamp.
- Connect together the master switch relay cables with a bolt.
- Reconnect the battery earth clamp.

The vehicle may now be towed to start the engine.

After the engine has run for a time and the batteries are sufficiently charged the master switch relay must be reconnected in the original configuration.

Proceed as follows:

- Switch off the engine.
- Disconnect the battery earth clamp.
- Restore master switch relay connections.
- Reconnect battery earth clamp.

#### Towing other vehicles



The vehicle to be towed may not be heavier than 25 tonnes.



## ITS BOVA

ITS BOVA deal with emergencies and strandings, free, 24 hours per day, 365 days per year.

### ITS BOVA can be contacted on



+31 (0)40 2948080

The international code for the Netherlands is 00-31 from most EC countries.

### NB:

This applies to countries outside the Netherlands: a BOVA coach which is stranded in the Netherlands must be repaired by an affiliated DAF dealer.

To use the ITS service you need the following information:

This information is on the identification papers, the ID card supplied with the coach and on the identification plate in the entrance to the vehicle. Make sure you have this information with you when phoning:

- Vehicle type
- Year of construction
- Vehicle owner
- Chassis number
- Registration number
- Name of the workshop where the vehicle is serviced (home dealer).
- Exact location of the vehicle (ask someone who is familiar with the area).
- Telephone number where you can be reached.
- Suspected cause of the breakdown.
- Proof of guarantee
- ID card, to help identify the correct spares

If the home dealer is offering a payment guarantee for a repair, the invoice from the repairing dealer goes to the owner through the home dealer. This also applies to any BOVA spares supplied.

In this way the driver does not have to pay for any repairs and he can express in his own language what the cause of the breakdown is.

Once a driver has contacted ITS for assistance, he must not leave the place mentioned without first reporting this to ITS.

### BOVA service and spares delivery

In the Netherlands:

On working days from 8.00 to 17.00



+31 (0)40-2084611

In a number of countries the DAF dealer can supply both BOVA and DAF parts from stock.

# 6 IDENTIFICATION

- VEHICLE IDENTIFICATION..... 124
- ENGINE NUMBER ..... 126
- ENGINE IDENTIFICATION PLATE 126
- AQUACLIME UNIT IDENTIFICATION PLATE ..... 126
- PAINT IDENTIFICATION ..... 127
- KEY AND IDENTIFICATION NUMBERS ..... 128
- ID CARD ..... 128

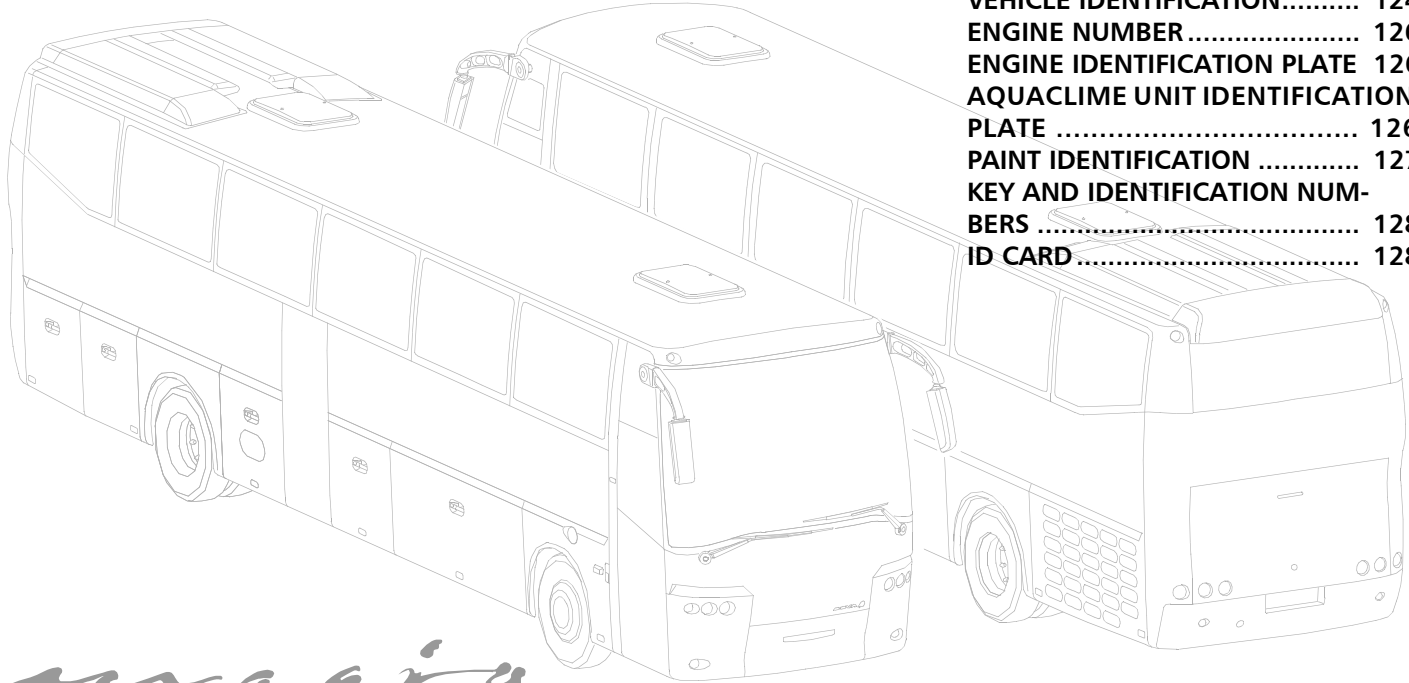

*magiq*





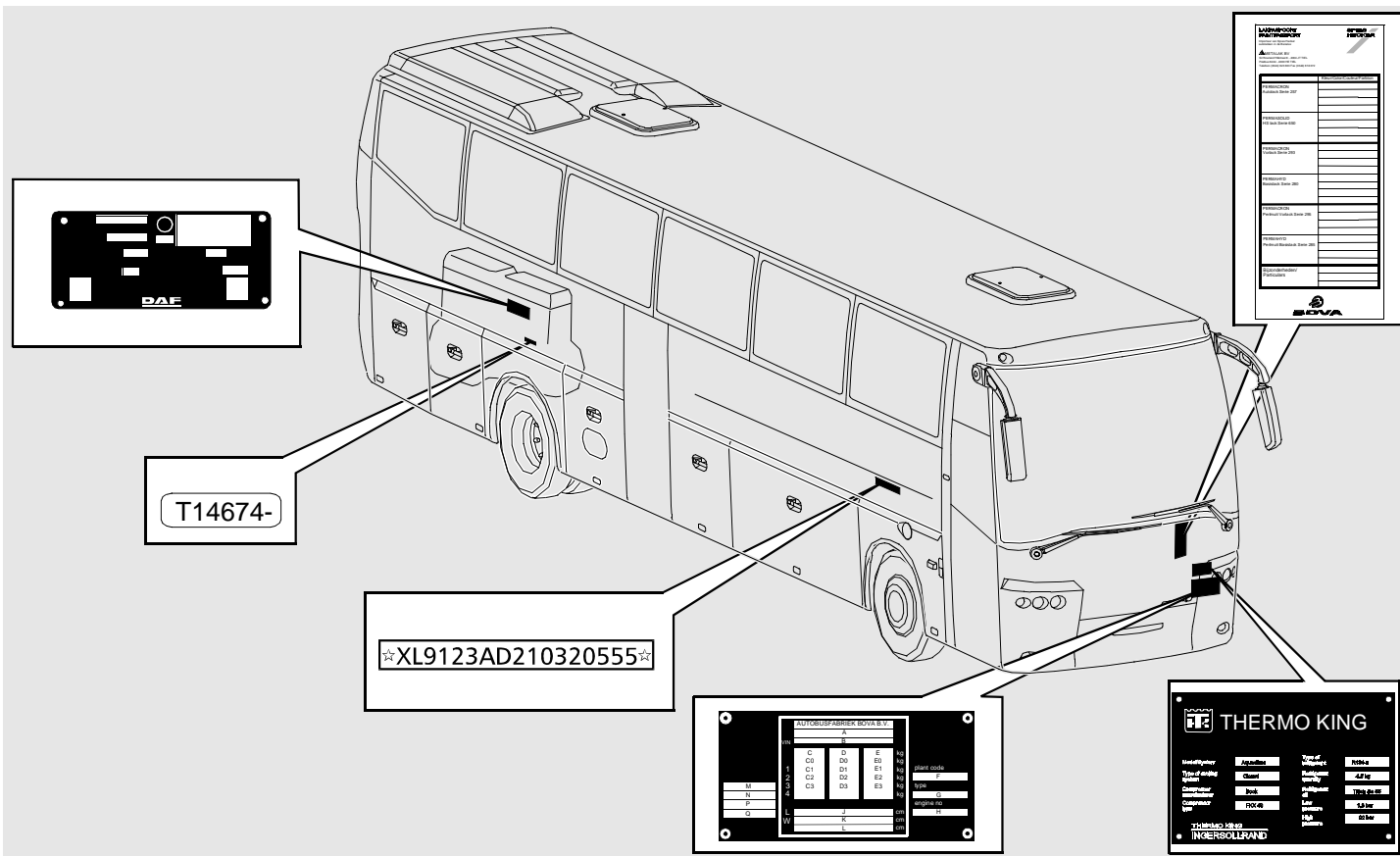

## VEHICLE IDENTIFICATION

The identification plate is located at the entrance to the front of the vehicle.

A	Approval number
B	Chassis number
C	Maximum permitted axle loads in the country for which the vehicle was produced (see country code)
D	Maximum permitted combined axle loads (usually EC)
E	Maximum technically permissible axle loads (all countries)
F	Country code
G	Type
H	Engine number
J	Length of coach
K	Width of coach
L	Combination length
M	Year
N	Various
P	Absorbption figure
Q	Spare

AUTOBUSFABRIEK BOVA B.V.			
A			
B			
VIN	C	D	E
1	C0	D0	E0
2	C1	D1	E1
3	C2	D2	E2
4	C3	D3	E3
			kg
			kg
			kg
			kg
			kg
			kg
	L	J	cm
	W	K	cm
		L	cm
M			
N			
P			
Q			
			plant code
			F
			type
			G
			engine no
			H

235850

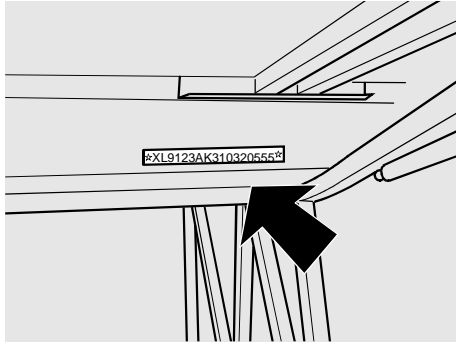

10006A

### Chassis number

The chassis number is made up according to the international V.I.N. standard (Vehicle Identification Number).

The last 8 figures of the chassis number form the BOVA chassis number. Always mention these 8 figures when communicating about the vehicle, e.g. when ordering parts. For controlling authorities the chassis number is also imprinted in the chassis beam in the right hand luggage area.

Example: XL9123AK310320555

XL9	Company identity
1	4 x 2 (two axles, one driven)
23	Body type
AK	Engine: DAF
3	Diesel emissions according to EURO-III
10555	Serial number
320	WMI-code

### Axle loads

The maximum axle loads as stated in sections C, D and E are distributed as follows:

Blank	Total weight
0	Train weight (including trailer)
1	Axle load, front axle
2	Axle load, rear axle
3	Axle load, trailing axle
4	Spare

### Country code

Stated here is the country the vehicle was produced for. The country codes of the Dutch approval body RDW are found here.

### Type indication

Example: HD120-340XE

HD	High version
120	Coach length in decimeters
340	engine (hp)
XE	DAF



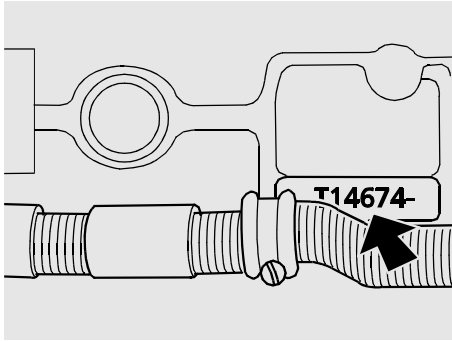

10013A

## ENGINE NUMBER

The engine number is stamped into the engine block above the starter motor.

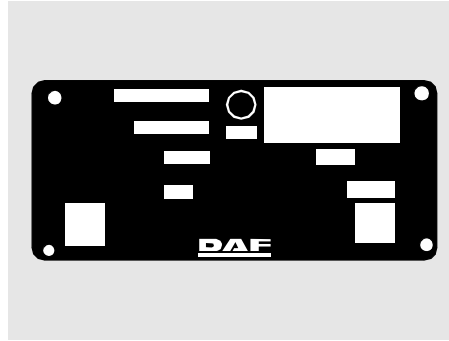

10014A

## ENGINE IDENTIFICATION PLATE

The engine identification plate is on the inlet manifold. The engine type, engine number and certain adjustment data are stated.

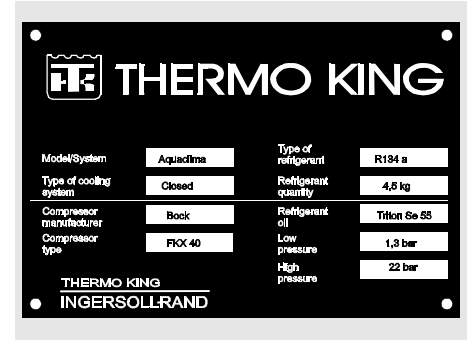

10020A

## AQUACLIMA UNIT IDENTIFICATION PLATE

The plate includes details of the climate system, the compressor and the coolant medium.

<b>LAKPASPOORT</b> <b>PAINTPASSPORT</b>		<b>SPIES</b> <b>HECKER</b>
<small>Inspreker van Spiess Hecker          vnlakwerken met de BOVA's</small>		
<b>BOVA</b> <small>NETALAK BV</small> <small>De Boerlaan 10/11a - 4004 PT TIEL</small> <small>Postbus 6244 - 4000 BR TIEL</small> <small>Tel: 03041 622 622 Fax: 03041 618 372</small>		
	<b>Kleur/Color/Couleur/Farbtön</b>	
<b>PERMACRON</b> Autolack Serie 257		
<b>PERMASOLID</b> HS lack Serie 650		
<b>PERMACRON</b> Vorlack Serie 293		
<b>PERMAHYD</b> Basislack Serie 280		
<b>PERMACRON</b> Perlmutt Vorlack Serie 295		
<b>PERMAHYD</b> Perlmutt Basislack Serie 285		
Bijzonderheden/ Particulars		
		

10012A

## PAINT IDENTIFICATION

The paint identification and paint supplier are indicated on a sticker on the inside of the cover below the

hostesses seat. The most important information on this sticker is the international RAL numbers which enable paint of exactly the same colour to be ordered from any local paint supplier. If possible BOVA always uses a RAL colour, unless the owner wants his own (company) colour. In these cases a code is mentioned which denotes the composition of that particular colour which remains available from BOVA. To avoid mistakes when ordering paint it is advisable always to include the chassis number along with the RAL numbers.



## KEY AND IDENTIFICATION NUMBERS

A number of keys are supplied with each vehicle. When replacing, e.g. one boot lid lock, it is possible to order a new lock with the same lock number as the rest. Keys with a specific serial number can be supplied afterwards.



**We strongly advise you to note the numbers of the keys.**



**Identification numbers for the various items of equipment fitted to the coach can also be reported here.**

	Key and identification number:
Ignition key	
Dashboard box	
Driver's box	
Passenger door	
Central door	
Emergency door	
Luggage flap	
Bonnet	
Filler cap	
Safe	
toilet	
toilet locker	
Refrigerator	
TV	
Video	
Radio	
CD player	
Navigation system	
Alarm system	

## ID CARD

All important components of your vehicle and their identification numbers are listed on this card.



**If you are stranded and contact ITS BOVA you must have this card with you.**

# 7 TECHNICAL DATA

- ENGINE ..... 131
- WHEELS AND TYRES ..... 131
- FLUID AND LUBRICANT SPECIFICATIONS..... 133
- ELECTRICAL COMPONENTS..... 136
- VEHICLE DIMENSIONS ..... 138

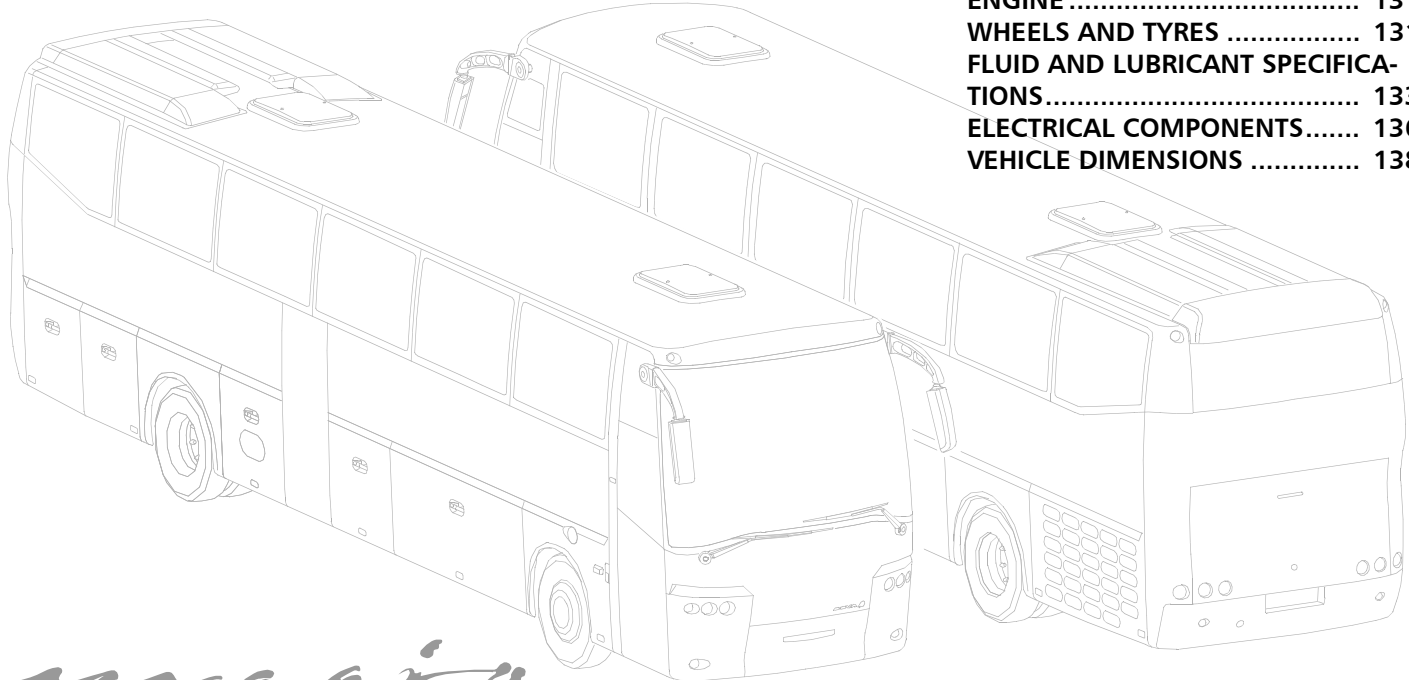

*magiq*





## ENGINE

Make	DAF	
Type	XE 250 C1	XE 280 C1
Location	Vertical, behind rear axle	
Engine configuration	4 stroke diesel engine, direct injection, 6 cylinders in line, turbo and intercooler	
Number of valves	24	
bore x stroke	130 x 158	
Capacity	12,58 litre	
Compression ratio	17.4:1	
Engine capacity	250 KW (340 hp) at 1900 rpm	280 KW (380 hp) at 1900 rpm
Maximum unloaded engine speed	2270 ±30 rpm	2270 ±30 rpm
Maximum engine speed loaded	1900 rpm	
Maximum torque	1600 Nm between 1000-1450 rpm	1750 Nm between 1000-1500 rpm
Speed limiter	via UPEC engine management	
Emissions	Euro 3	

## WHEELS AND TYRES

295/80 R 22,5 Michelin XZA2 tyres fitted as standard on steel rims 8.25 x 22,5.

### Tyre pressures

The tyre pressures given here are those appropriate to the stated maximum axle loads, when the vehicle is used under normal conditions. For all other cases see the tyre manufacturer's table.

Axle load (kg)	Pressure (bar)
7100 (front)	8,5
11500 (rear)	8.0

### Torque

The wheel nut torque  
615 Nm.



Retighten wheelnuts after 100 km.

## Winter tyres

If winter tyres are fitted they must be fitted to all four wheels.

The maximum speed specified by the manufacturer must not be exceeded.

Where winter tyres are used we recommend that the tyre manufacturer's guidance be followed regarding tyre pressures.

## Snow chains

The driver of a vehicle fitted with snow chains may have to comply with legal requirements such as traffic sign 268.

This makes the use of snow chains compulsory when the road surface is icy or under snow.



The chains must consist of small links which do not protrude, so as to avoid them scraping on the suspension and other parts.

 **Speeds above 50 km/h are not permitted when snow chains are in use.**

Avoid driving with snow chains fitted where there is no snow, as this causes highly accelerated wear to tyres and chains.

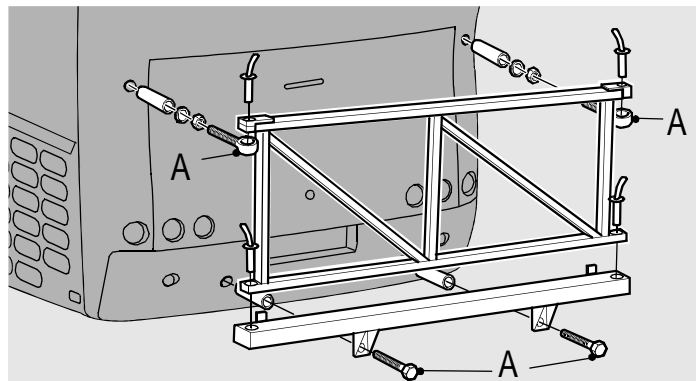

10022A

## Ski box

When mounting a ski box, use only the special rack designed for your vehicle, in combination with the mounting points on the vehicle.

Securing bolt (A) torque: 1040 Nm

 **Comply with the legal requirements regarding the use of a ski box.**

The maximum total load on the mounting points (luggage, mounting rack and ski box together) is 800 Kg.

 **Swing the ski box on its hinges only when unloaded.**

## FLUID AND LUBRICANT SPECIFICATIONS

### General

In this section the lubricants and fluids are specified which must be used in maintaining the BOVA Magiq. Your supplier of these lubricants can advise you on which products meet the specifications described.

The information provided in this section applies for normal driving conditions and the quantities are approximate. In extreme conditions (e.g. outside temperatures below -20 °C or above 40 °C advice must be requested from BOVA service or the manufacturer of the part in question.



**Avoid skin contact with fuels, lubricants and coolants.**

### Engine

Type	DAF XE250C1/XE280C1
Lubrication oil specification	15W-40 / ACEA-E3
Contents incl. filters and oil cooler	39.5 litre

### Cooling system

Coolant specification	ASTM D 3306, BS 6580 and SAE-J-1034
Cooling/heating system capacities	75 litres approx.

As standard the cooling system of the BOVA Magiq is filled with "DAF Coolant -37". This is a mono ethylene glycol based ready to use coolant with anti-corrosion additives in demineralised water. Frost protection is guaranteed down to -37 °C.



**Coolant medium is toxic. Protect skin and eyes. Coolant medium is damaging to the environment, and must therefore be treated as industrial waste.**



**Never fill with propylene glycol, since ethylene and propylene glycol are incompatible.**



**Anti-freeze coolant medium must still be used even if the vehicle is used in areas where the temperature never falls below 0 °C, since the coolant temperature in the aquaclime system may fall below 0 °C.**

## Gearbox

Type	ZF-6S 1600	ZF-8S 180	ZF 5HP600
Lubricant specification	SAE 30 API CD/CE/CF/SF/SG		ATF
Capacity when refilling	±14 litres	±12 litres	±15 litres
Number of gears	6	8	5

## Shift operation

Type	HGS	Automatic
Operation	Hydraulic-pneumatic	Electro-pneumatic
Fluid specification	Brake fluid DOT 4	-

## Clutch

Type	Single dry plate
Diameter	430 mm
Operation	Hydraulic
Fluid specification	Brake fluid Dot 4

## Rear axle

Type	<b>ZF A-132</b>
Ratio	1:2.93 (1:3.54 if automatic)
Axle bridge lubricant specification	SAE 80W-90 / API GL-5
Axle bridge capacity	16 litres approx.

## Front axle

Type	<b>ZF RL 75 E</b>
Lubricant specification Hub	Lithium soap grease (NLGI class 2, grease type KP2K-40)
Grease specification Grease nipples	Lithium soap grease (NLGI class 2, grease type KP2K-30)

### Steering gear

Type	ZF 8098
Fluid specification	ATF Type DEXRON-IID or ATF MERCON-M
Capacity	10 litres approx.
Turning angle	60°
Ratio	1:22.2/26.2

### Hydraulic drive

Ventilator and air conditioning compressor	
Fluid specification	ATF type DEXRON 3 mineral based.
Capacity	25 litres approx.

### Fuel

Diesel fuel must comply with specification EN 590. In extremely low temperatures a maximum of 20% kerosine may be added.

Where this is not permitted by law, a maximum of 20% lead free petrol may be added.



**Where diesel fuel with a sulphur content greater than 0.2% is used, the engine oil change interval should be shortened to a maximum of 25,000 km.**

Fuel should satisfy the following lubricity standard:  
Test method: HFRR according to norm CEC-F-06-A96  
Test value: < 460  $\mu\text{m}$

Fuel tank capacity: 2 x 400 litre approx.



## ELECTRICAL COMPONENTS

### Starter motor

Type Bosch JE  
Capacity 6.2 kW

### Dynamos

Type Alternating current  
Capacity 28 V x 100 A

### Batteries

Number 2  
Voltage 12 V  
Capacity 230 Ah

### Windscreen wiper system

Wiper blade length 100 cm  
Reservoir capacity 14 litres

### Tow hook junction box

D+ connection Maximum 2 A  
Constant supply Maximum 7.5 A

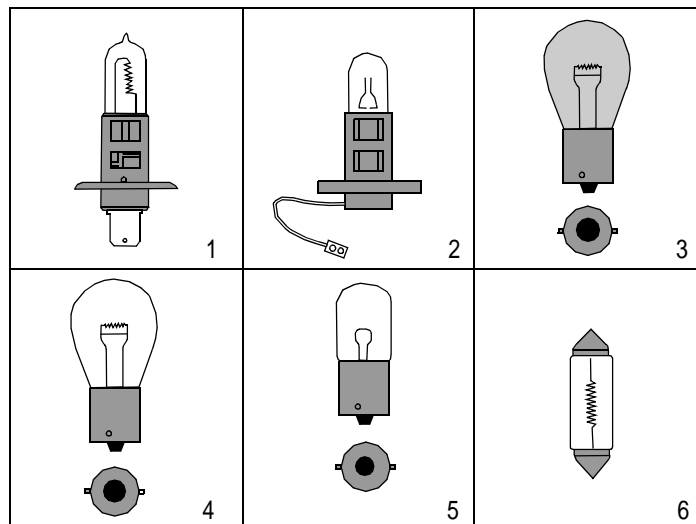

20007A

### Lighting

		Number	Type	Capacity
A	Headlamps (H1)	2	1	70 W
B	Main beam (H1)	2	1	70 W
C	Foglamps (H3)	2	2	70 W
D	Parking light (front)	2	6	5 W
E	Front indicator lamp	2	3	21 W
F	Side indicator lamp	2	4	21 W
G	Rear indicator lamp	2	4	21 W
H	Rear lamp	2	5	5 W
I	Brake light	2	4	21 W
J	Rear fog lamp	1	4	21 W
K	Reversing lamp	1	4	21 W
L	Third brake light	1	LED	--
M	Side profile lamps	12	LED	--
N	Top lighting	4	6	5 W
O	Registration plate lighting	2	6	5 W
	Luggage space lighting	8	6	5 W
	Engine compartment lighting	2	6	5 W

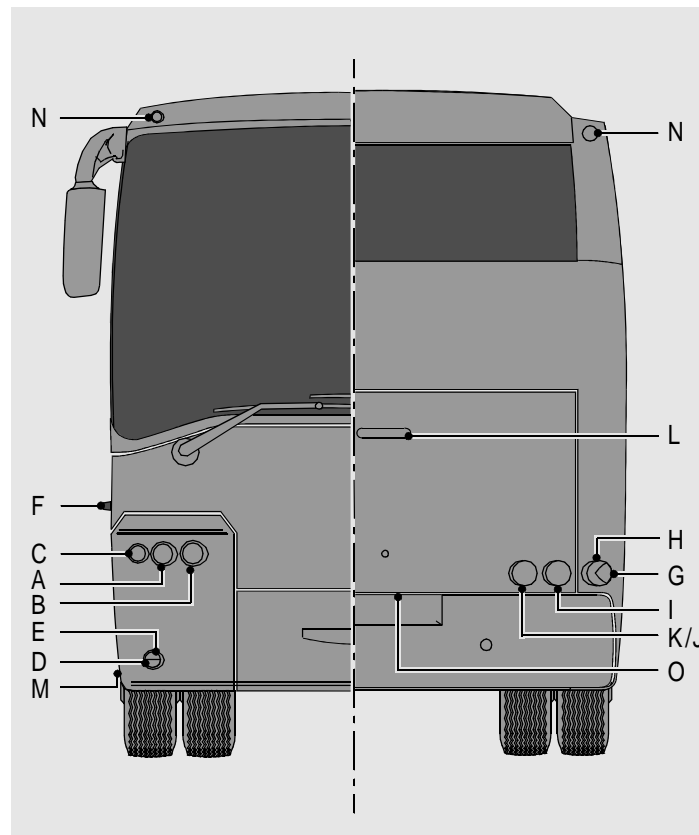

## VEHICLE DIMENSIONS

Specified weights and dimensions are given in the following table. The actual weights (in particular) of the vehicles can vary from these specifications depending on the options installed. Before delivery the vehicles are weighed and a copy of the weight registration form stating the actual empty weight is added to the delivery documents. Weights are expressed in kilograms and dimensions in millimetres.

	<b>HD 120 340XF/380XE</b>
Total length	11990
Total height including roof unit (A)	3570
Total width (B)	2540
Rear overhang (C)	3300
Wheelbase (D)	6150
Front overhang (E)	2540
Interior height	2025
Front entry step height	342
Centre entry step height	368
Turning circle	20700
Empty weight	13400 approx.
Maximum front axle load	7100
Maximum rear axle load	12000
Maximum total weight	19100
Luggage compartment capacity	10.5 m <sup>3</sup>

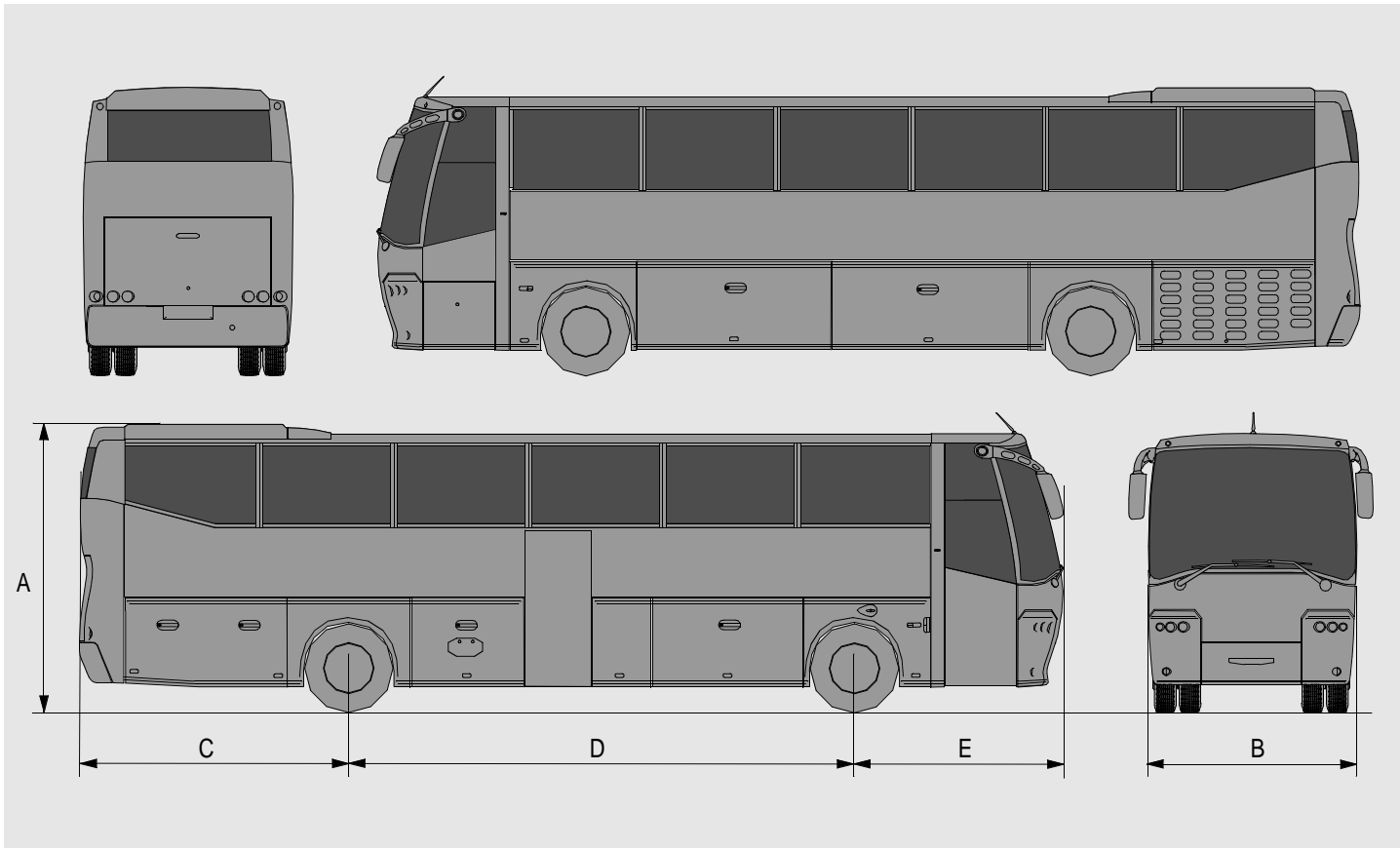



## 8 SUBJECT INDEX

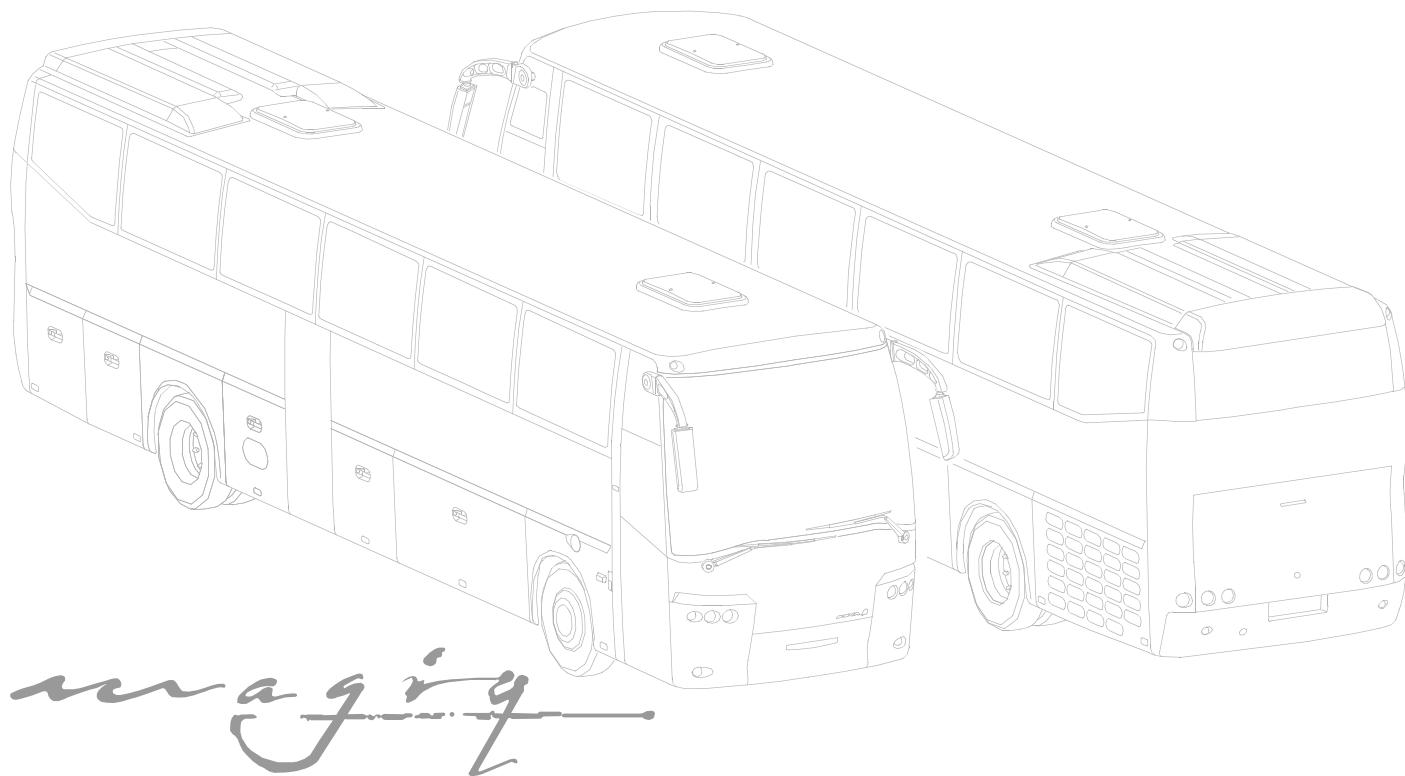



<b>A</b>		<b>C</b>		Driver's compartment lighting .....31
ABS system .....109		Central door .....22, 46		Driver's seat .....42
Accelerator pedal .....39		Central greasing .....94		Driver's sleeping compartment ....68
Accu's .....87		Chassis number .....125		Drivers locker .....19
Adjusting v-belt tension .....106		Cigar lighter .....32		<b>E</b>
Air filter .....90		Clock .....28		Electrically operated driver's screen .21
Air leaks .....7, 11		Clutch .....7, 9		Emergency hammers .....81
Air suspension (ECAS) .....71		Clutch fluid .....92		Emergency operation
Air suspension leaks .....109		Clutch pedal .....39		-Luggage flaps .....79
Air-conditioning system .....12		Combi-switch left .....25		-Passenger and central door ....78
Anti-smog .....31		Combi-switch right .....29		-Sleeping compartment hatch ...79
Anti-tilt system .....72		Coolant level .....89		Emergency procedures .....81
Aquaclime unit identification		Coolant temperature .....29		Emergency switch .....21
plate .....126		Cruise control .....29		Engine brake .....24
Audio .....32				Engine identification plate .....126
<b>B</b>		<b>D</b>		Engine number .....126
Batteries .....6		Dashboard switches central .....31		Engine oil level .....88
-Charging .....6		Dashboard switches left .....20		Engine stop button .....11
Battery compartment .....16		Dashboard switches right .....46		
Bell-push switch .....32		Demister .....31		<b>F</b>
Bleeding fuel system .....108		Direction indicator, left .....25		Fire extinguisher .....79
Bonnet .....15		Direction indicator, right .....25		First aid kit .....80
Brake pedal .....39		Display .....29		Fluid and lubricant specifications 133
Brake system air dryer .....91		-Brightness adjustment .....29		Fog lamp front .....20
Braking .....10		-Clock/Tripmeter .....28		Fog lamp rear .....20
Bremsomat .....30		-Descriptions .....51		Fuel gauge .....28
		-Messages .....47		



Fuses			
-Pre-heater warning lamp	115		
<b>G</b>			
Gear shifting			
-ZF 5HP automatic gearbox	41		
-ZF 6 S 1600 gearbox	39		
-ZF 8 S 180 gearbox	40		
General hints	8		
<b>H</b>			
Hazard warning lights	32, 81		
Hazard warning triangle	81		
Head lamp washers	25		
Horn	25		
Hostess call switch	32		
Hostess seat	47		
Hydraulic fluid	90		
Hydraulic Gearshift fluid	91		
<b>I</b>			
ID card	128		
Ignition switch	23		
Inspection lamp connection	104		
Inspection lamp plug	105		
Instrument panel	26		
Interior lights	21		
ITS BOVA	120		
<b>J</b>			
Jacking points	111		
Jump starting	116		
<b>K</b>			
Kitchen	71		
<b>L</b>			
Luggage	5		
Luggage compartment left	47		
Luggage compartment right	47		
Luggage doors	16		
Luggage flaps left	31		
Luggage flaps right	31		
<b>M</b>			
Magiqair-system	109		
Main beam (flash)	25		
Main/dim beam	25		
Maintenance			
-Checklist	86		
-Daily checks	88		
-Exterior	97		
-For winter	95		
-Interior	99		
-Weekly checks	89		
-When winter is over	97		
Master switch	21		
Mirror adjustment	19		
Mirrors	73		
Mobile telephones	6		
<b>N</b>			
Navigation system	33, 71		
Night lights	20		
<b>O</b>			
Odometer	26		
On-board tool kit	104		
<b>P</b>			
Paint identification	127		
Parking brake	19		
Parking/dipped lights	20		
Passenger door	15, 22, 46		
Passenger seats	66		
Passenger's reading lamps	20		
Personal setting units	67		
Power steering fluid	90		
<b>R</b>			
Raising/kneeling	72		
Raising/kneeling, front	22		
Raising/kneeling, rear	22		
Reading lamp	47		

Rear fog lamp .....	20	Spoiler flap handle .....	26	<b>W</b>	
Refrigerator .....	41	Standby heater timer .....	43	Warning lamp	
Releasing the parking brake .....	117	Starting procedure .....	9	-ABS .....	26
Replacing bulbs .....	112	Steering adjustments .....	23	-ECAS control symbols .....	71
-Front indicator lamps .....	113	Steering gear .....	72	-Indicators .....	28
-Headlights .....	113	Stopping/Parking .....	10	-Main beam .....	26
-Rear lights .....	114	Storage box .....	45	-Parking brake .....	28
-Side indicator lamps .....	114	Switching off engine .....	11	-Priority warning 1 .....	28
Replacing fuses .....	114	System voltage .....	6	-Priority warning 2 .....	28
Replacing v-belts .....	105			-Retarder .....	28
Retarder .....	30	<b>T</b>		-Tachograph .....	26
Revolution counter .....	28	Tachograph .....	33	-Trailer indicator .....	28
Roller shutter left hand .....	21	Toilet .....	70	Warning symbols .....	5
Roller shutter right hand .....	21	Touching up paintwork .....	99	Warning triangle .....	5
Roof hatches .....	77	Tow hook junction box .....	136	Warranty conditions .....	7
Roof unit dust filters .....	92	Towing .....	116	Water system .....	94
Running in .....	8	Towing eye .....	104, 117	Welding .....	6
		Transmitters .....	6	Wheels and tyres .....	110, 131
<b>S</b>		Tripmeter .....	28	Windscreen washers .....	25
Safety belts .....	80	Tyre inflation .....	112	Windscreen wipers .....	25
Safety requirements .....	5	Tyre pressures .....	131	Winter conditions .....	5
Screenwash reservoir .....	91			Winter tyres .....	132
Service and spares delivery .....	120	<b>V</b>			
Service documentation reply form .....	147	Vehicle dimensions .....	138		
Ski box .....	132	Vehicle identification .....	124		
Snow chains .....	132	Ventilation grill .....	32, 45		
Spare wheel .....	110				
Speed limiting device .....	11				





## BOVA SERVICE DOCUMENTATION REPLY FORM

If you have any suggestions and/or comments concerning this manual or if you find any faults, please fill out this form and send it to:

Autobusfabriek BOVA b.v. afdeling Service documentatie Postbus 5 5550 AA Valkenswaard Fax: +31 (0)40 2019477		Company name : .....		
		Name : .....		
		Signature : .....		
<b>Chassis number</b>		.....		
<b>Concerning Document ordernumber:</b> .....		<b>Version:</b> .....		
<b>Type of document:</b> (mark what is applicable)	Drivers manual	<input type="checkbox"/>	Futurair manual	<input type="checkbox"/>
	Maintenance manual	<input type="checkbox"/>	Electrical diagrams	<input type="checkbox"/>
	Workshop manual	<input type="checkbox"/>	Training manual	<input type="checkbox"/>
	Parts catalogue	<input type="checkbox"/>	Others	<input type="checkbox"/>
<b>Kind of inaccuracy</b> (mark what is applicable)	Linguistic (Definition) not correct	<input type="checkbox"/>	Mistake in technical data (values)	<input type="checkbox"/>
				<input type="checkbox"/>
<b>Explanation</b>		..... ..... ..... ..... .....		

BOVA will take your report seriously and, if necessary, we directly make an update in the document.

