

Drivers manual

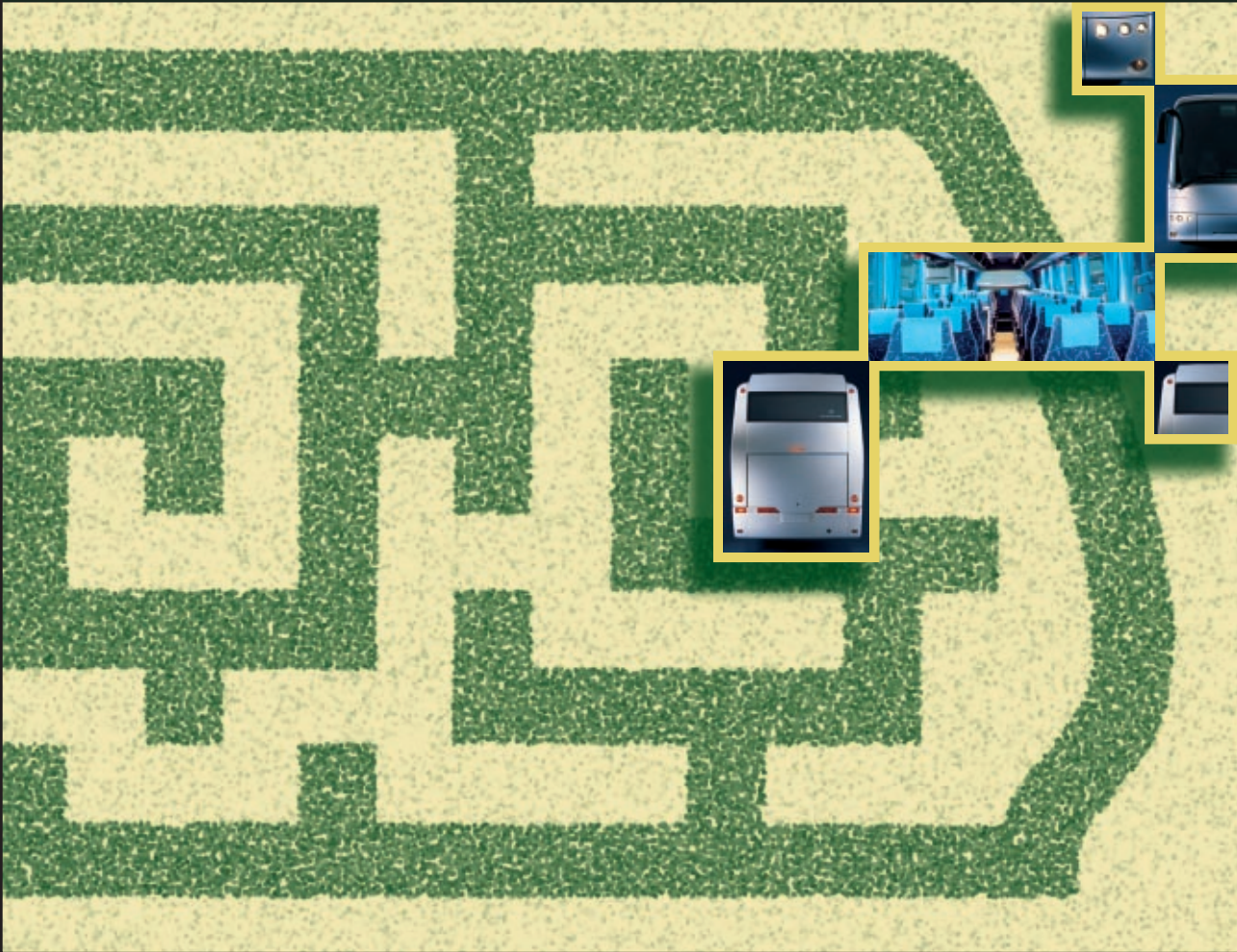

Futura



BOVA

While this manual has been written with the greatest of care, Autobusfabriek BOVA b.v. can not be held responsible for any deficiencies or the consequences thereof.

The specifications, designs and illustrations in this manual have no binding effect.

We reserve the right to make changes without prior notice.
Nothing in this publication may be copied or made public without prior written permission from BOVA.

Autobusfabriek BOVA b.v.
Afdeling Service
Postbus 5
5550 AA Valkenswaard (NL)

Version 1, January 2003
Order number: B267755GB

Futura

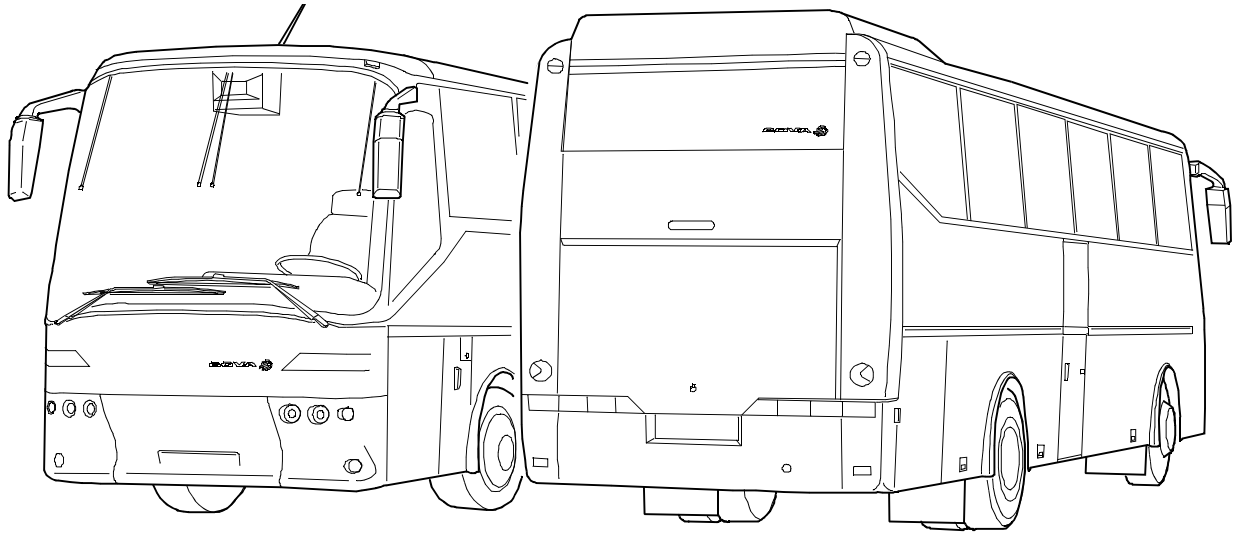

Ch 30003751++

F30130

CONTENTS

1	INTRODUCTION	1
2	CONTROLS AND OPERATIONS .	13
3	SAFETY REQUIREMENTS AND EMERGENCY PROCEDURES	55
4	MAINTENANCE	61
5	RUNNING REPAIRS	83
6	IDENTIFICATION	103
7	TECHNICAL DATA	111
8	SUBJECT INDEX	123

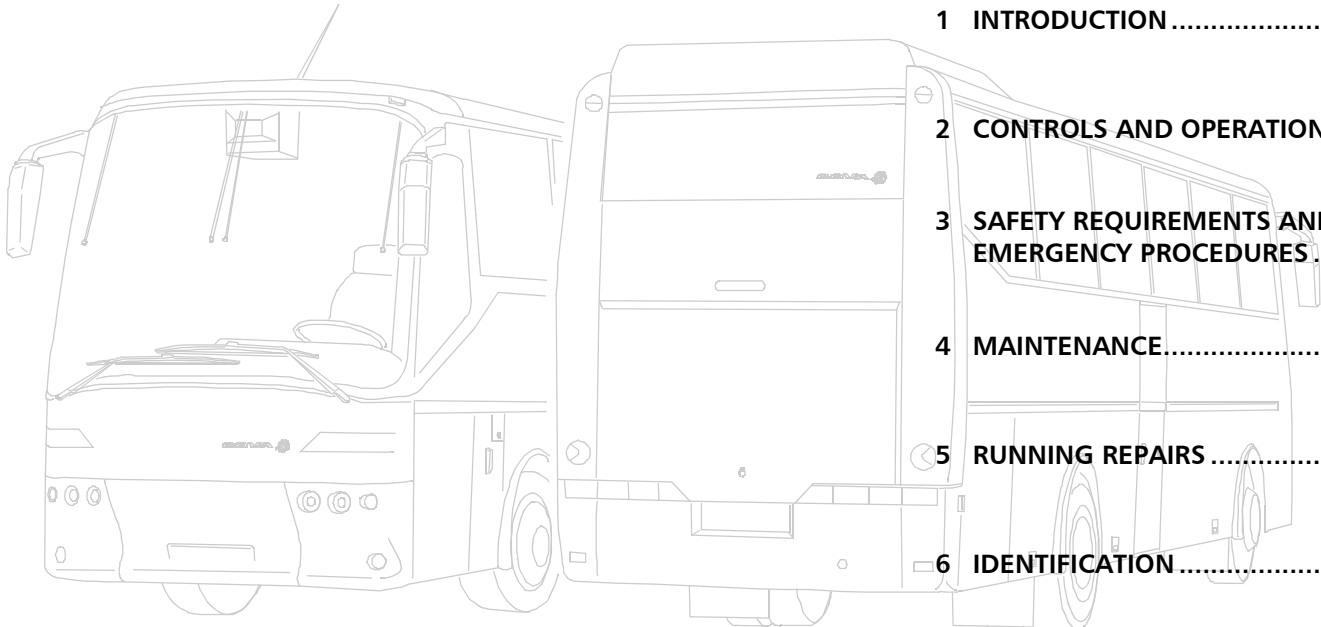

Futura

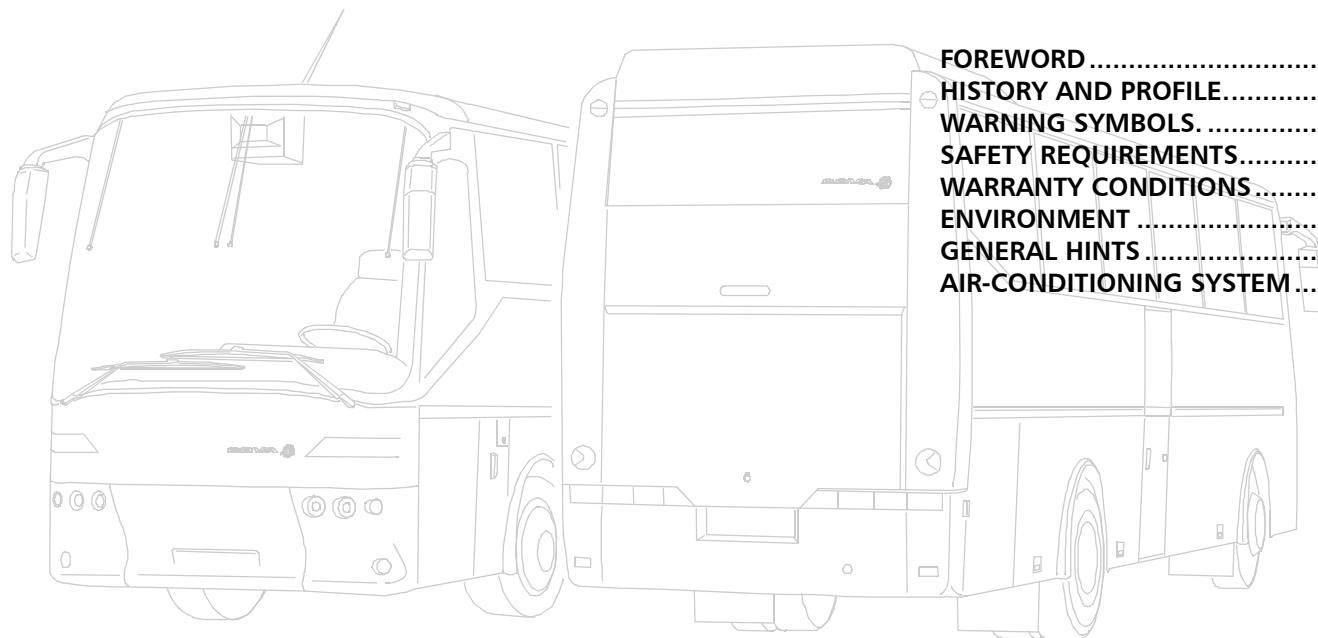

1 INTRODUCTION

FOREWORD	3
HISTORY AND PROFILE.....	4
WARNING SYMBOLS.....	5
SAFETY REQUIREMENTS.....	5
WARRANTY CONDITIONS.....	7
ENVIRONMENT	8
GENERAL HINTS	8
AIR-CONDITIONING SYSTEM.....	11

Futura

FOREWORD

Congratulations on purchasing your BOVA Futura.

You've made a good choice

The BOVA Futura has outstanding ride quality, performance and reliability, low fuel consumption and an emphasis on safety and comfort.

Reliability, durability, safety and a comfortable ride are the hallmark of **BOVA** products.

A careful reading of this manual before driving the vehicle for the first time will help make the most of these characteristics and fulfill your expectations.

A thorough knowledge of the maintenance instructions will increase driver satisfaction and will above all have a favourable influence on the durability of the vehicle. The capabilities of the vehicle can be fully exploited.

Aim

The aim of this manual is to familiarise the driver or user with the vehicle, so BOVA need to pass on as much information as possible about the use, operation, safety and maintenance of the vehicle.

The manual includes information about standard and optional features.

Alternative equipment, for example manual or automatic transmission, is discussed.

This means that you may skip certain sections in the manual which deal with equipment not fitted to your vehicle.

Layout

The layout of the manual is designed to be practical and to provide an overview.

There are 8 chapters in the manual.

Each chapter begins with a detailed contents section which will help you find your way around the relevant chapter.



An index at the end of the manual will enable speedy location of topics.



Make sure this manual is always in the vehicle and read through it carefully before first driving it.

HISTORY AND PROFILE.

Jacob Bots started out as a timber merchant in Valkenswaard in 1878. His son Simon introduced the name **BOVA** in 1910: it comes from **BO**ts **VAl**kenswaard.



Our logo refers to this history, with the B from Bots and the falcon (valk) as symbol of Valkenswaard, which was renowned from ancient times as a centre of falconry.

Since 1931 BOVA's core activity has been the development, production, sale and service of luxury coaches. BOVA have been building integral coaches for more than 30 years and have built up extensive experience in this advanced construction method for coaches.

BOVA try always to develop lasting relationships with our business partners, on a basis of trust: clients are central to this.

We put a lot of effort into helping them optimise the return on their investment.

This calls for: minimal costs per mile, the highest possible quality standards, maximum comfort and optimal safety for passengers and drivers.

BOVA can rely on a well-trained and highly motivated workforce, both at our Valkenswaard headquarters and abroad.

Our organisation is flexible, but continues to search for ways to broaden this flexibility. Our sales division have

premises in the Benelux countries, Germany, France, Switzerland, Italy, Spain, Poland and Denmark. We have a branch in Sweden and importers in Great Britain, Czechoslovakia and elsewhere.

BOVA ensures the continuity of the business by using all means at our disposal to produce the finest products. Production processes, development, logistics, quality assurance, marketing and service are continually monitored and optimised, to ensure that everyone concerned has the most up to date methods and tools at their disposal. This serves to further the interests of the customer, as well as our workforce, suppliers and shareholders.

WARNING SYMBOLS.

You will find the following symbols in your manual.

Take note of the tip or warning accompanying the symbol!



This symbol gives useful tips to simplify operations.



This symbol indicates that extra care is required.



This symbol indicates a situation which might result in damage to the vehicle.



This symbol indicates a situation which might result in personal injury.

SAFETY REQUIREMENTS

Strict adherence to the following safety requirements is necessary to prevent risk to your own or others health and safety.

Warnings and safety instructions.

Always read the instructions and warnings on labels and stickers. Don't ignore them, they are there to ensure your safety and health!

Engine

Do not allow the engine to run in a closed or unventilated space.

Engine compartment

Keep away from moving parts.

Warning triangle

Always have a warning triangle available (it is a legal requirement in some countries) supplemented as necessary with other means of marking.

Winter conditions

Whenever severe winter conditions are expected make sure to fit winter tyres and carry snow-chains. See also: Wheels and tyres page 113.

Luggage

All luggage must be stowed so that it cannot shift or fly loose, even in an emergency stop. Bear in mind that the ride characteristics of a fully loaded vehicle differ from those of an empty vehicle.

Fluids and greases.

Various fluids and greases may damage the health through skin contact, ingestion or inhalation, so avoid physical contact wherever possible.

Spilled fluids may react aggressively with other materials, so clear them up as quickly as possible.

To prevent risk of fire the engine and its surroundings must be kept free of (highly) flammable materials.

Welding

When welding on the vehicle first the negative and then the positive cable should be disconnected from the batteries. Disconnect the alternators.

Place the earth clamp of the welding

apparatus as close as possible to the welding location and ensure a good contact with the item being welded. Do not connect the earth clamp to the axles. Take care that welding spatter does not land on plastic fuel pipes or on air lines or similar.

Batteries



Never disconnect battery cables while the engine is running!

Always disconnect the battery earth cable when working on the electrical system. Never place tools on a battery, they can cause short circuits and in the worst case the battery may explode.

Battery charging

During battery charging, provide good ventilation and avoid sparks and open flames.



Allow frozen batteries to thaw, and remove all filler caps before charging.

Connect the positive (+) lead from the battery charger to the positive (+) battery terminal first, and then connect the negative (-) lead to the negative (-) terminal. When charging is complete switch off the charging apparatus and then disconnect first the negative (-) and then the positive (+) lead. For "normal charging" the battery cables may remain connected. Use a high speed charger only in case of extreme urgency.



Both battery cables must be disconnected when carrying out high speed charging to avoid damage to vehicle electronics.



Do not use a speed starter set to start the vehicle as this may damage the vehicle electronics.

System voltage

The vehicle is provided with a 24 volt electrical system. When replacing or upgrading electrical or electronic components, ensure that these are suitable for this voltage.

Mobile phones and transmitters

The following precautions relate to the use of mobile phones and transmitters.

- Mobile phones and transmitters must not be used in the vehicle except via a separate external aerial.



The use of mobile phones or transmitters without a separate external aerial may cause excessive electromagnetic fields (the resonance effect) within the vehicle. It is possible that this may lead to

disturbances to the vehicle electronics.

- In addition, the optimum range of this equipment can only be achieved with the use of an external aerial.



Always follow the operating instructions for mobile telephones and transmitters.

Original BOVA parts.

Do not modify your vehicle with non-original BOVA parts.

Bear in mind that any modification to your BOVA vehicle with non-original parts may adversely affect its performance, safety, durability and the guarantee.

Modifications may also conflict with legal requirements.

WARRANTY CONDITIONS

The BOVA warranty covers faults in materials, construction and fitting, for new coaches, with normal use and maintenance, for a period of 12 months from the date of delivery of the vehicle, or from first registration.

For further details see BOVA's general warranty conditions.

ENVIRONMENT

To prevent unnecessary damage to the environment, you should observe the following guidelines:

- Waste fluids should be carefully collected and segregated, and should then be delivered to an authorised site for recycling or disposal.
- Improper disposal of fluids may be a criminal offence.
- Ensure that the vehicle is regularly maintained. A properly maintained vehicle uses fuel more efficiently and emits less harmful exhaust gases.
- Don't allow the engine to run unnecessarily when stationary, and always drive using the appropriate engine speed.

GENERAL HINTS

Take note of the following recommendations before using the vehicle in traffic.



The roof hatches should be unlocked before the journey commences.

Filling fuel tanks

Use only diesel fuel of satisfactory quality.

Make sure that the filler cap and the area around it are free from dust, and avoid mixing water with the fuel during filling.



To prevent water condensation, avoid allowing the level of fuel in the tank to fall unnecessarily low.

Running in

It is advisable to avoid high performance of the vehicle during the running-in period.

This also applies when a reconditioned engine, gearbox or differential has been fitted.

For the first 1500 km you should therefore:

- Avoid driving under full load.
- Change down in good time: a relatively high engine speed is less harmful than overloading the engine with excessively low engine speeds.
- Do not drive with a trailer attached.



Following a cold start, use a moderate engine speed and avoid heavy acceleration until the coolant temperature reaches 50 °C.

Keep a regular eye on the instrument panel while driving and respond alertly when irregularities are observed.

Wheel nuts.

The wheel nuts must be retightened (650 Nm) when 100 km have been travelled following delivery of the vehicle.

The wheel nut torque must be checked again after a further 500 km.

Fuel economy

Driving economically isn't simply driving slowly, it requires anticipation and a fluid style, and adapting the driving style to the existing conditions.

Keep in mind:

- Warm up the engine as quickly as possible by driving off as soon as possible under moderate load.
- Drive smoothly, avoiding unnecessary acceleration and harsh braking.
- Change gear in good time and keep the engine speed in the optimal (green) range.

The most significant factor in fuel consumption is the driver himself and how he uses the accelerator pedal, the brake pedal and the gear lever.

Starting procedure



The engine can not be started with the bonnet open.

Turn on via the master switch.

Depress the clutch pedal (not applicable to vehicles with automatic gearbox) and select neutral gear.

If the temperature is low the preglow system will come into effect automatically.

The electronic unit automatically determines the required preglow and afterglow periods.

The glow time required depends on the temperature as measured by the engine management system.

Switch on the ignition.



When the engine starts, the engine speed should not be increased until the oil pressure lamp is extinguished.

Clutch

Wear on the clutch depends to a great extent on the driver.

To reduce clutch wear to a minimum, follow these guidelines:

- On moving off, select first gear and where possible a low engine speed.
- On accelerating after a gear change, give gas only after the clutch is fully engaged.
- Avoid riding the clutch.
- Avoid unnecessary acceleration in traffic queues.
- Use the brakes to stop.

Braking

The vehicle is equipped with an ABS braking system.

The ABS braking system prevents the wheels locking during braking on slippery road surfaces or in an emergency stop.

The ABS system only switches in at maximum braking, at the moment when one or more wheels lock and the vehicle threatens to skid.

At that instant the ABS system allows the brake pressure to fall until the wheel begins to rotate and grip on the road surface is restored. The braking force is then immediately increased until maximum braking is achieved, or until the wheel in question locks up and the cycle is repeated.

The vehicle thereby remains fully steerable in such conditions and a stable course is maintained.



Don't adapt your driving and braking to the ABS system.

In particular, don't brake later and harder, as this wears the tyres and may cause difficulties for other road users.



Braking distances with ABS are sometimes, but not always shorter.

On starting, the ABS signal lamp will be illuminated while the system checks are performed. The lamp should go out after a few seconds. If the lamp remains on, or comes on during a journey, there is a fault in the ABS system.

Normal braking function will be maintained but there is a possibility of the wheels locking during heavy braking.

The ABS system must now be tested in a workshop.

Stopping

Bring the vehicle to a halt.

Select neutral gear.

Allow the clutch pedal to rise (not applicable to vehicles with automatic gearbox).

Parking

Stop the vehicle.

Operate the parking brake by means of the brake lever.

When parking on an incline the following should be considered:

- Place chocks in front of or behind the wheels.
- Turn the front wheels so that the vehicle will not head out into the thoroughfare if it should move for any reason.

Switch off the ignition and master switches.

Switching off engine



After a long journey or when it has been put under heavy load, allow the engine to idle while stationary for a while before switching off.

Park the vehicle. Stop the engine by first switching off the ignition. Then turn off the master switch.

Air leaks.

A rapidly falling air pressure reading with a stationary engine indicates a leak. The leak must be repaired without delay as the safety of the braking system is impaired.

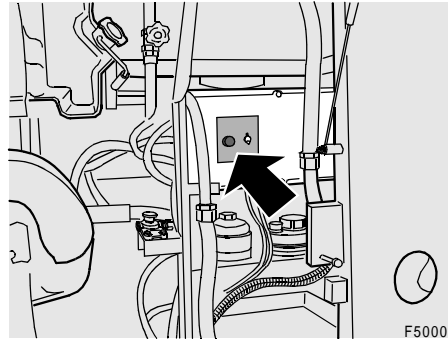

Engine stop lever in the engine compartment.

The engine can if necessary also be stopped using the stop button in the engine compartment (underneath in the GB version).



Remember to reset the stop button before closing the engine compartment.

Speed limiting device

The speed limiting device on your vehicle is set at 100km/h.

AIR-CONDITIONING SYSTEM

On 1 January 1993 the "Substances affecting the ozone layer" law came into force in the Netherlands. The purpose of this law is, among other things, to drastically reduce coolant emissions from cooling installations. The following measures accordingly apply:

- The use of CFC's in new installations is forbidden
- Technical requirements are placed upon cooling installations
- Work on cooling installations may only be done by qualified personnel.
- The responsibilities of the owner/operator of the installation are being increased. Implementation is by means of a logbook and maintenance obligation.

The intended reduction in emissions can only be effective with the recording of the use of coolants and their control.

STEK (only the Netherlands)

For cooling installations in Dutch coaches recording must take place with the use of a logbook. Also, periodic maintenance for such installations is compulsory. Recording of this must also take place in the logbook. Both obligations apply for existing and new installations. Control is carried out by inspectors from STEK by order of the Ministry of Housing and the Environment.

A CFC logbook has been introduced to simplify the control of technical cooling installations. This logbook complies with the instructions issued by the STEK and is supplied with each BOVA coach. The logbook must also be presented each time there are repairs and/or a change to the system.

2 CONTROLS AND OPERATION



INTRODUCTION.....	15
CONTROLS AND INSTRUMENTS ..	17
SWITCHES WITH NO FIXED LOCATION.....	48
SIGNAL LAMPS WITHOUT FIXED LOCATION.....	50
DRIVER'S SEAT.....	51
PASSENGERS' AREA.....	52

Futura

INTRODUCTION

The function and operation of the instruments and controls are described in this chapter.

The BOVA Futura comes in several versions, and components and their operation may also vary from the standard because of specific national requirements or custom options. The most usual configurations are discussed in this chapter, and it is therefore possible that an installed option is not described here, or that there are variations from what is described here. In that case the user's guide provided by the supplier of the option is usually provided with the vehicle.

The section "Components with a fixed location" describes the equipment which, when it is fitted, occupies a specific location in the cockpit.

The descriptions of the remaining components, which are often associated with optional equipment, are divided between the sections "Signal lamps with no fixed location" and "Switches with no fixed location".

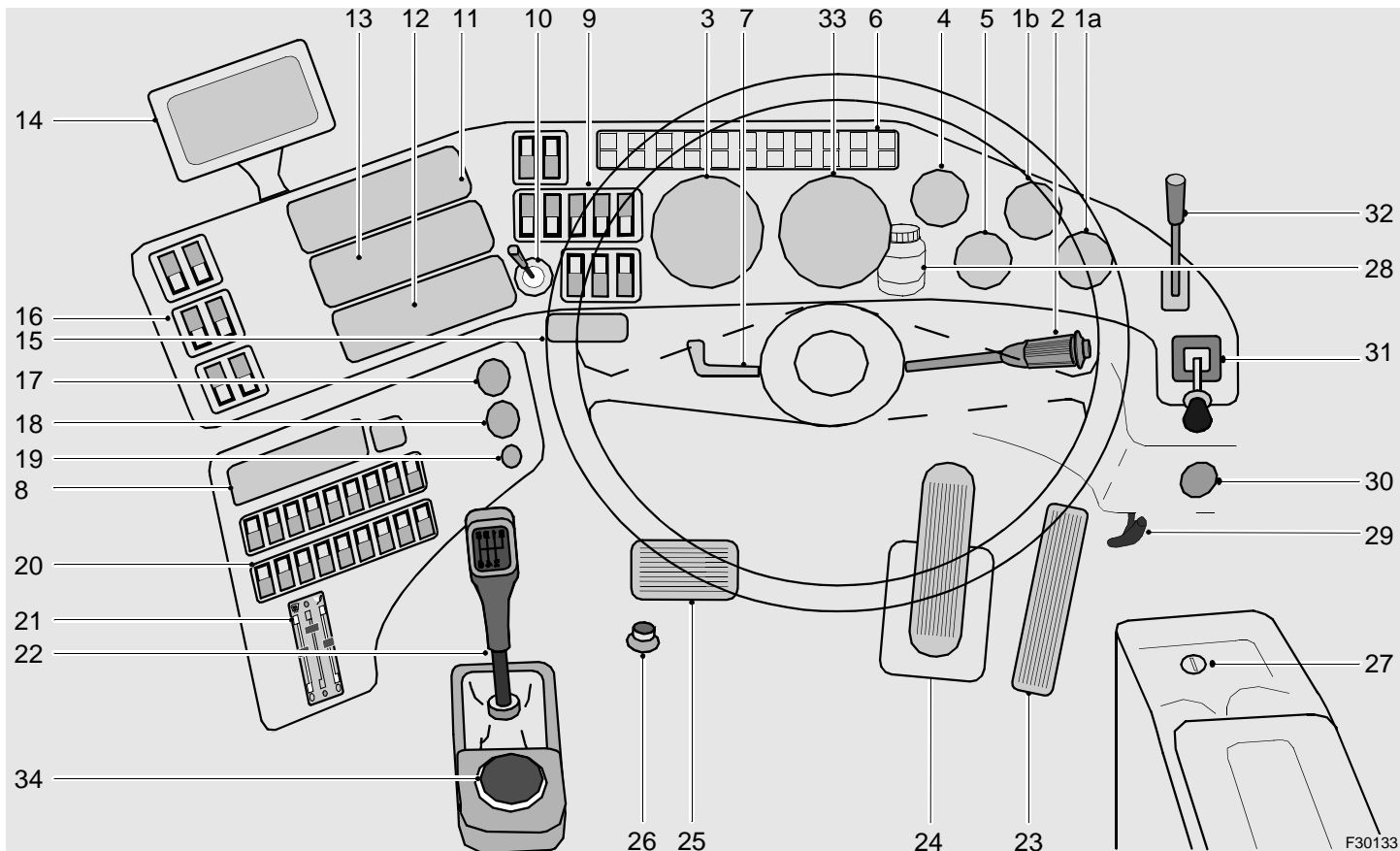

F30133

CONTROLS AND INSTRUMENTS

1	Air pressure gauge, circuits 1 and 2	17
2	Combi-switch	18
3	Rev counter	19
4	Coolant temperature gauge	19
5	Fuel gauge	19
6	Signal lamp group	20
7	Steering wheel adjustment lever	24
8	Tachograph	24
9	Switch group	30
10	Cruise control	32
11	Climate system controls	35
12	Audio amplifier	36
13	Radio cassette	36
14	Navigation system	36
15	Ashtray	36
16	Switch group	37
17	Cigar lighter	38
18	Front door operation	38
19	Central door operation	38
20	Switch group	40
21	Front heater operating slides	43
22	Gear lever	44
23	Accelerator pedal	44
24	Brake pedal	44
25	Clutch pedal	44
26	Engine brake	44
27	Stowage space	45
28	Clutch fluid reservoir	45

29	Spoiler flap opening handle	45
30	Ignition key mechanism	45
31	Parking brake	46
32	Retarder operating handle	47
33	Speedometer	48
34	HGS fluid reservoir	48

1 AIR PRESSURE GAUGE, CIRCUITS 1 AND 2

The air pressure gauges show the pressure in the air receivers for the two separate service brake circuits. If the pressure in the parking brake circuit is lower than around 5 bar (kg/cm) a buzzer sounds and a signal lamp illuminates.

The parking brake can be released when the pressure rises above 5 bar. The buzzer operates only when the ignition is on. The gauges show only the pressure in the air receivers. The maximum air receiver pressure in the air system is 8.1 bar. Expended air is replaced by the compressor when the pressure falls to around 7.5 bar.



If the pressure in one of the circuits is lower than 5 bar, the vehicle may not be driven.

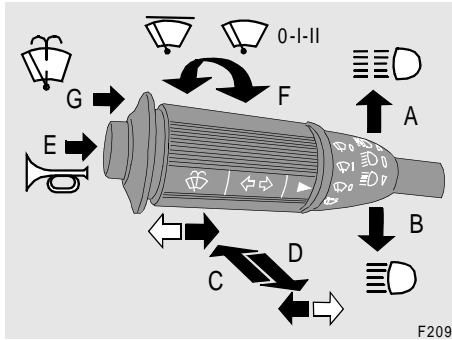

2 COMBI-SWITCH

Dipped beam/Main beam/Indicators

In the neutral (middle) position, the dipped beam is on when the lighting switch is on.

A	Indicator (independent of the lighting switch position)
B	Main beam (only when the lighting switch is fully depressed)

Direction indicators

To briefly operate the indicators, hold the switch against the spring pressure. The indicators operate only when the ignition is on.

C	Direction indicators, right.
D	Direction indicators, left

Air horn

Pressing button E operates the air horn.

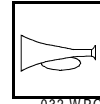

032.WPFG

Windscreen wipers

Turning switch F operates the windscreen wipers.

	Intermittent position: in this position the windscreen wipers operate once every 8 seconds
0	Wipers off
I	Normal wiper speed
II	Same as 1 (increased wiper speed if connected)

Windscreen wipers operate only when ignition is on.

Windscreen washers

Windscreen washers operate when ring G is depressed, and the windscreen wipers also operate twice. Windscreen washers operate only when ignition is on. Headlamp washers (optional) operate simultaneously with the windscreen washers.

3 REV COUNTER

This meter shows the number of engine revolutions per minute. A colour code on the scale indicates favourable and less favourable engine speeds.

Green	Economical
Red	Prohibited region

4 COOLANT TEMPERATURE GAUGE

The coolant operating temperature must be between 87 °C and 99 °C



The engine must not be fully loaded where the coolant temperature is below 50 °C

If the coolant temperature rises above 110 °C, the warning lamp will illuminate and a buzzer will sound.

5 FUEL GAUGE

The gauge operates only when the ignition is switched on. An extra fuel tank (optional) may be connected to the standard tank. The gauge then shows the combined level of both tanks.

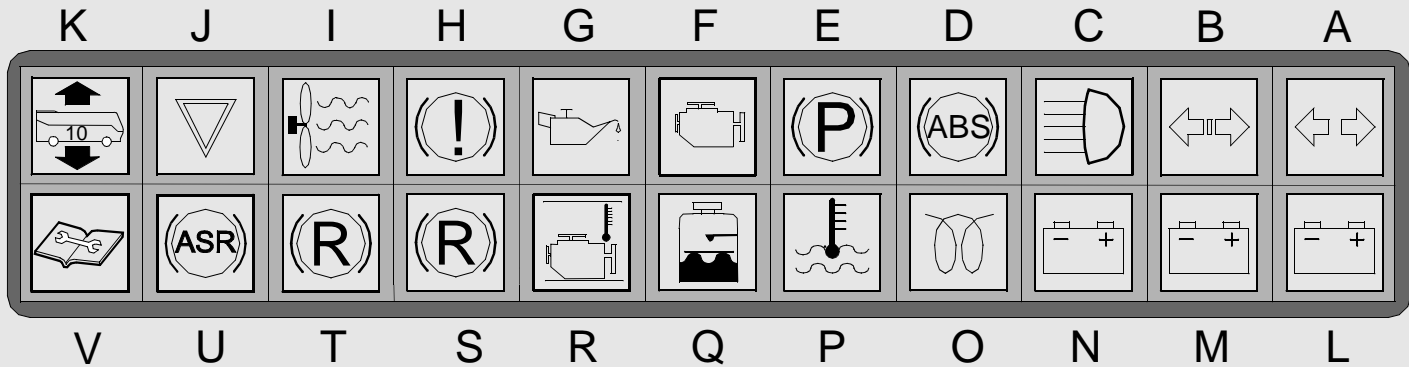

F30134

6 SIGNAL LAMP GROUP

A	Direction indicators (green)	21	K	Raising/kneeling (yellow)	22
B	Direction indicators (green)	21	L	Dynamo 1 charging current (red)	22
C	Main beam (blue)	21	M	Dynamo 2 charging current (red)	22
D	Brake anti-lock system (red)	21	N	Dynamo 3 charging current (red)	22
E	Parking brake (red)	21	O	Preglow/afterglow system (yellow)	23
F	Engine management system (yellow)	21	P	Coolant fluid temperature (red)	23
G	Oil pressure (red)	21	Q	Coolant fluid level (red)	23
H	Minimum air pressure (red)	22	R	Engine compartment temperature (red)	23
I	Cooling system hydraulic drive (red)	22	S	Retarder (green)	23
J	Sleeping compartment emergency alarm (red)	22	T	Retarder (red)	23
			U	ASR system (yellow)	23
			V	CXB fault (yellow)	24

A Direction indicators (green)

Signal lamp A shows the operation of the vehicle's indicator lights

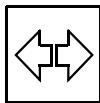

F30000

B Direction indicators (green)

Signal lamp B shows the operation of the direction indicators connected to the trailer connector junction box (optional).

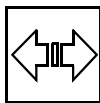

F30175



When a direction indicator lamp fails or the trailer connector is not connected, the relevant signal lamp does not illuminate.

C Main beam (blue)

This signal lamp indicates that the main beam is on.

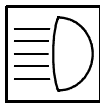

F30001

D Brake anti-lock system (red)

When the ignition is switched on this lamp should illuminate for a few seconds and then extinguish.

If the lamp does not extinguish, or comes on during a journey, there is a fault in the ABS circuit. The vehicle's braking circuit continues to function but the anti-locking function will not operate. A BOVA service point should be consulted and the fault investigated. Following repair, the lamp should extinguish only when the speed rises above 7km/hr.



F30004

E Parking brake (red)

This signal lamp illuminates when the parking brake (handbrake) is on.



F30005

F Engine management system (yellow)

This lamp illuminates when there is a fault in the engine management system.

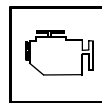

F30135

G Oil pressure (red)

This lamp provides a warning that the oil pressure in the lubrication system is too low.

This lamp must illuminate when the ignition is switched on and extinguish as soon as the engine is running.



Should the oil pressure lamp come on when the engine is running, stop as soon as possible in a safe place and switch off the engine. Check the oil level.

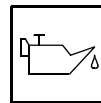

F30010

H Minimum air pressure (red)

This lamp illuminates if the air pressure in one of the brake circuits is too low. The journey cannot be continued.



F30013

If this lamp comes on during a journey there is sufficient air in the system to perform an emergency stop.



Stop the vehicle as soon as possible in a safe place and have the fault repaired.

I Cooling system hydraulic drive (red)

This lamp illuminates for a few seconds when the ignition is switched on but will also illuminate or flash when there is a defect in the cooling system hydraulic drive. The cooling system fan will then operate at maximum capacity.

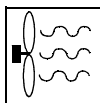

F30136

J Sleeping compartment emergency alarm (red)

This lamp will illuminate if the person in the driver's sleeping compartment operates the emergency knob.

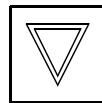

F30014

K Raising/kneeling (yellow)

The symbol indicates that the raising/kneeling system is in operation.

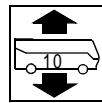

F30143



Switching on the raising/kneeling system limits the vehicle speed to 10 km/h.

L Dynamo 1 charging current (red)

This lamp should illuminate when the master switch and the ignition are switched on. The lamp should go out when the engine is started and up to speed. One or more lamps will behave abnormally if there is a fault in the charging circuit.

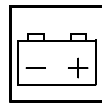

F30002



In case of fault, check dynamo V-belts. Replacing V-belts page 85.



The journey may continue in the case of a defect in one of the dynamos, but the dynamo capacity will be limited. As few electrical consumers as possible should therefore be operated.

M Dynamo 2 charging current (red)

See description for dynamo 1 charging current.

N Dynamo 3 charging current (red)

See description for dynamo 1 charging current.

O Preglow/afterglow system (yellow)

This lamp is illuminated when the preglow system is in operation.

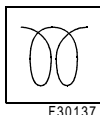

P Coolant fluid temperature (red)

This lamp will illuminate, and a buzzer will sound, when the coolant temperature rises above 110 °C . Stop the vehicle as soon as possible in a safe place and check the following

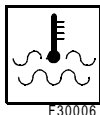

- Coolant fluid level
- V-belts and water hoses

 See the "Maintenance" and "Running repairs" sections for the correct procedures and data.

Q Coolant fluid level (red)

This lamp illuminates when the coolant level in the expansion tank falls below the minimum level.



Park the vehicle as soon as possible and top up the cooling system.

R Engine compartment temperature red)

This lamp will illuminate when the temperature in the engine compartment is too high.

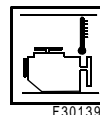

Stop the vehicle as soon as possible in a safe place, switch off the engine and the master switch. The cause of the fault must be identified and repaired before the journey can be continued.



The warning may indicate a fire in the engine compartment. In that case, take the passengers as quickly as possible to a place of safety.

S Retarder (green)

This lamp will be illuminated whenever the retarder is switched on and operating.



Reduced effectiveness of the retarder will be indicated by flashing of the signal lamp.

T Retarder (red)

This lamp will illuminate when there is a fault in the retarder.



U ASR system (yellow)

This lamp will illuminate when the ASR system is operating.



When the ASR system operates, this indicates that the road surface is slippery.

V CXB fault (yellow)

This lamp will illuminate for a few seconds when the ignition is switched on, but also when the motorstop in the engine compartment is activated or when there is a fault in the CAN extension box.



The journey may continue but you should contact a service centre as soon as possible and have the fault repaired.

7 STEERING WHEEL ADJUSTMENT LEVER

Turning the lever a quarter turn to the left allows the steering wheel position to be adjusted.

The lever should be tightened by turning to the right once the steering wheel is in the desired position.



Caution! The steering wheel must only be adjusted when the vehicle is stationary.

8 TACHOGRAPH

General

The tachograph disc has a maximum recording capacity of 1 day (24 hours). The tachograph disc(s) must therefore be replaced at 24 hour intervals, at most.

Driver 1 (the current driver) and driver 2 (the current co-driver) each have their own tachograph disc. (If a driver changes vehicles he must bring his own tachograph disc with him to the new vehicle, and sign to indicate the change of vehicle on the rear of his disc).

The tachograph disc must be removed at the end of a shift or when changing vehicle.



The tachograph disc should not be left in place if the vehicle is out of use for an extended period, for example during maintenance or repairs.

The tachograph drawer can only be opened:

- When the vehicle is stationary.
- When the ignition is on.
- When there is no error message on the display.

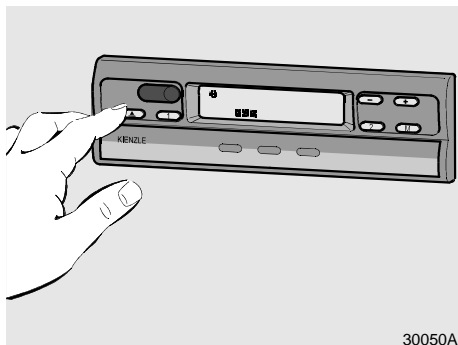

30050A

Inserting tachograph discs

- Push button  in. The symbol "opening activated" will appear. At the same time a moving bar will appear to show that this may take a little time. Wait until the drawer is unlocked.

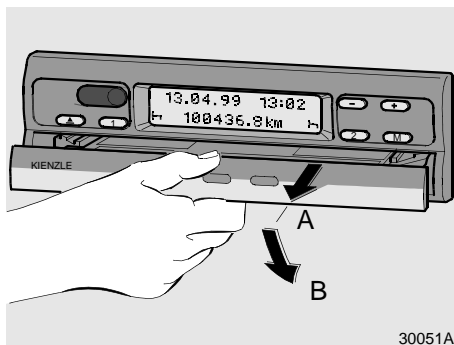

30051A

- Fixed drawer (A): pull the drawer out until the stop is reached. Fold-away drawer: (B): pull the drawer out until the stop is reached and fold down.



Do not attempt to fold away the fixed drawer.

- Remove driver 1's (current driver's) disc if present.

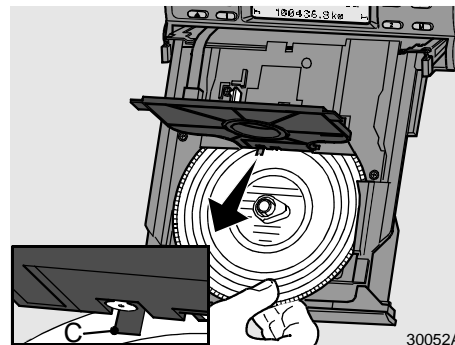

30052A

- Swing the intermediate plate up and remove driver 2's (the co-driver) disc, if present.



The new tachograph disc must be correctly completed before it is inserted

- Place driver 2's tachograph disc with the front upwards in the oval disc holder.
- Ensure that the disc is located below spring element (C).
- Swing the intermediate plate back down.

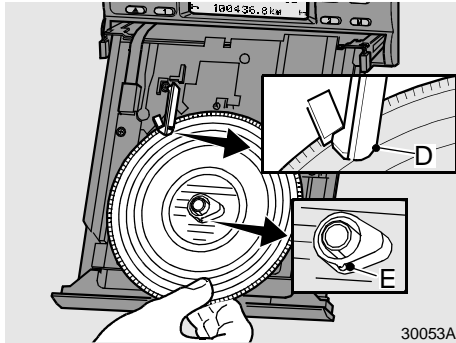

Place driver 1's tachograph disc on the intermediate plate, with the front upwards. Ensure that the tachograph disc is located below holder (D) and cam (E).

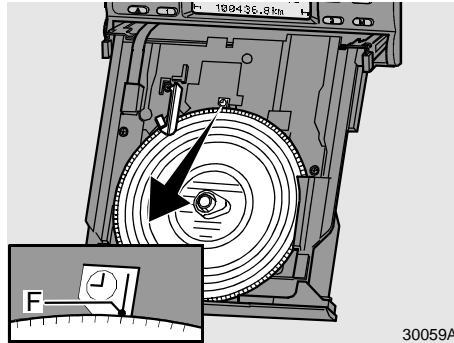

Check the position of the tachograph disc holder. The time division on the disc at mark (F) must agree with the actual time on the display.

Synchronise tachograph recorder

- Open the drawer and remove both tachograph discs.
- Close the drawer: the tachograph will now synchronise the timescale division with the time on the display.
- Now open the drawer and replace the tachograph discs. The tachograph is now ready for use.

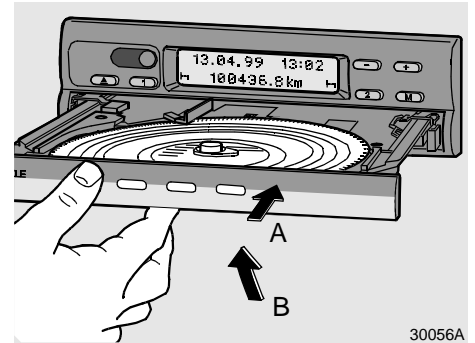

Fixed drawer (A):

Slide the drawer in up to the stop.

Foldaway drawer (B):

Bring the drawer into a horizontal position and slide the drawer in up to the stop.

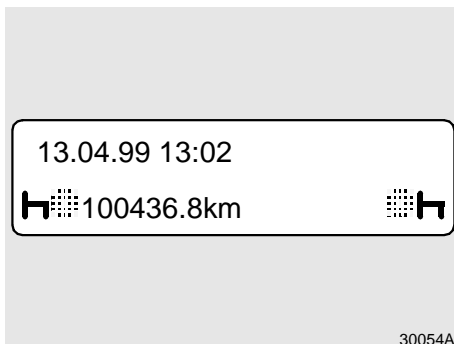

Core information

Core information such as date, time, speed and mileage are now shown. The symbols for the tachograph discs inserted are also shown, as well as the actual time group positions, left for driver 1 and right for driver 2.

Remarks

The time on the tachograph is set as the time in the country where the vehicle was registered. Adjustments for the beginning and end of Summer Time are made automatically.

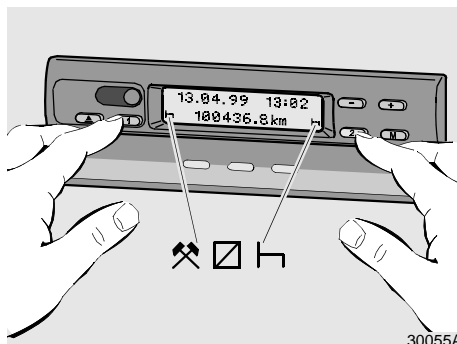

Set time group

For use by 2 drivers

Driver 1 (current driver) operates the key **1**. Depress the key repeatedly until the desired time group appears
 Driver 2 (current co-driver) operates the key **2**. Depress the key repeatedly until the desired time group appears in the display.

If the vehicle moves, the following items appear in the display:

- for driver 1 "⊗" and
- for driver 2 "◻"

The vehicle speed also appears in the display

For use by a single driver

For use by a single driver, only the tachograph disc for driver 1 need be placed on the intermediate plate.

- The time group for driver 2 must then be placed on rest time **H**, otherwise an error message will appear

Time group divisions

Time groups are divided into:

- ⊗ Driving time
- ⚡ All other working time, for example loading and unloading
- ◻ Waiting time
- H Breaks and rest periods

Changing drivers

Example 1:

If driver 1 and driver 2 swap over, the tachograph discs must also be exchanged.

Driver 1 (now driver 2) now places his tachograph disc **under** the intermediate plate and driver 2 (now driver 1) places his disc **above** the intermediate plate.

The desired time groups must now be set.

The new driver 1 now operates key (1) and driver 2 operates key (2).

Example 2:

If driver 1 or driver 2 leave the vehicle they must take their tachograph disc with them.

Either the new driver 2 must place his tachograph disc under the intermediate plate, or the new driver 1 must place his tachograph disc on the intermediate plate.

If there is no new driver 2 the time group must be set on (rest time) \dashv , otherwise an error message will appear.

Example 3:

If drivers 1 and 2 leave the vehicle, then both must remove their tachograph disc from the machine. The new crew should place their discs in the machine according to their functions (as driver 1 and driver 2).

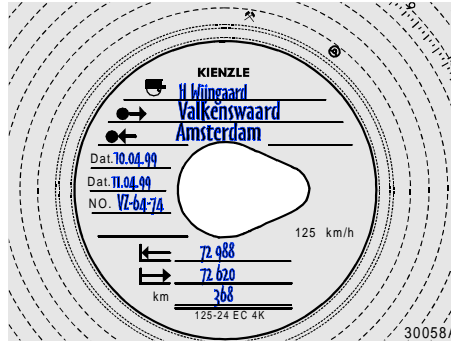

After removing the disc:

- ← Location at end of shift (bottom line)
- Dat. _____ Date at end of shift (bottom line)
- ← ← Mileage at end of shift (top line)
- Km Total miles travelled

Completing the front/centre of the disc.



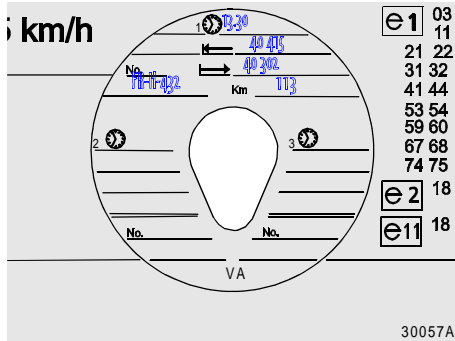

Prior to inserting the disc:

- Name of driver/co-driver
- → Location at start of shift.
- Dat. _____ Date at start of shift (top line)
- No. _____ Vehicle registration
- ⇒ → Mileage at start of shift (bottom line)



Completing the rear/centre of the disc

A maximum of three vehicle exchanges may be entered in this section:

-  Time of vehicle exchange
-  Registration of new vehicle
-  Starting mileage
-  Finishing mileage
-  Total mileage covered

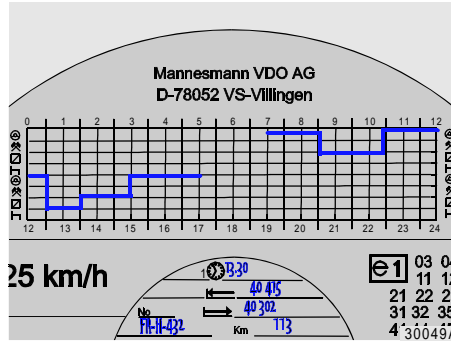

Completing the field around the edge of the rear of the disc

This field may be used for filling in time groups by hand. This may be necessary if the driver or co-driver is not working close to the vehicle and is therefore not available to operate the time group switch, or if there is a defect in the time group recording equipment. In such cases a line must always be drawn after the relevant symbol.

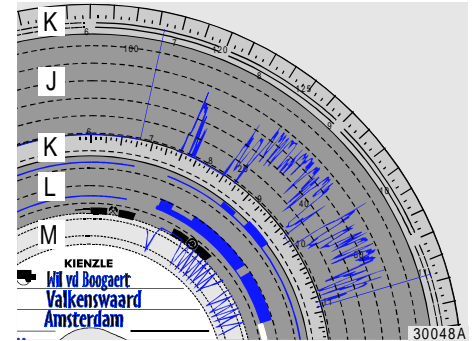

Recording on the front of the tachograph disc

The front of the tachograph disc includes the following sections:

- K: Time scales
- J: Speed recording
- L: Time group recording
- M: Distance recording

Faults

If a fault occurs with the tachograph, for example:

- No tachograph discs are inserted.
- A system component fails to operate correctly.

this is indicated by the appearance of an exclamation mark (!) in the display.

See the supplier's documentation provided for a detailed description of the tachograph and to order the correct replacement tachograph discs.

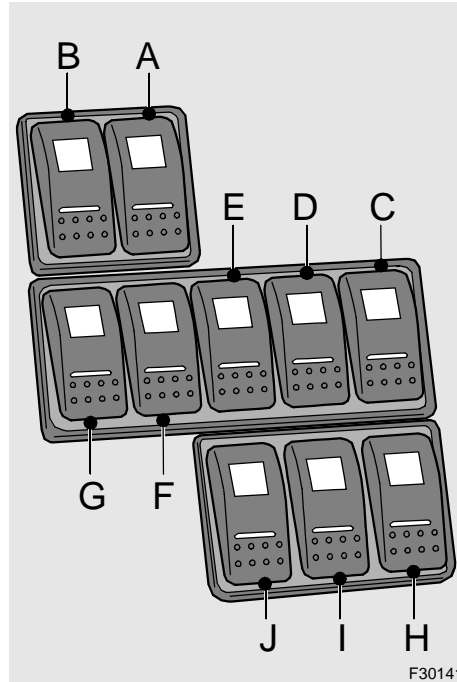

9 SWITCH GROUP

A Driver's illumination

Driver's illumination switches.



B Individual reading lamps

Reading lamps are fitted above the passenger seats. These may be operated by the passengers if the switch is on.

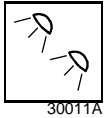

C Light switch

The switch controls the vehicle lighting and has three positions;

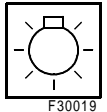

0	all lights off
1	sidelights on
2	sidelights and dipped beam on (if master switch and ignition are on).

In position 2, depending on the position of the combi-switch, the main beam is on.

D Front foglamps

Front foglamp switch.



These lamps can be used only if (at least) the sidelights are on.



E Rear foglamp

Switch for rear foglamp.



The rear foglamp can only be used if the dipped or main beam is on.

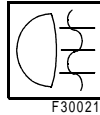

F Interior lighting

Interior lighting switches:

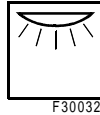

0	TL lighting off
1	TL lighting on

G Night illumination

Night illumination switches

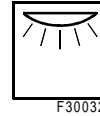

0	Night illumination off
1	Night illumination on

H Left roller blind

This rocker switch allows the roller blind to be raised and lowered.

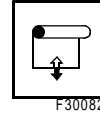

I Right roller blind

This tumbler switch allows the blind to be raised or lowered.

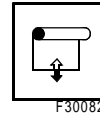

J Bremsomat

When the hydraulic retarder is in use, its braking action during a descent can also be automatically controlled (Bremsomat system). Bring the vehicle to the desired speed and press in the "set" switch on the underside. The position of the

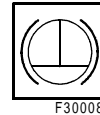

retarder operating handle is not significant.
The vehicle speed will now be limited to the speed you have selected, provided the braking capacity of the retarder is not exceeded.
To switch off the Bremsomat function, press the upper "off" switch. When the retarder operating handle is moved from position 0 to positions 1-4, automatic operation is temporarily suspended until it is returned to position 0. The retarder is operated manually in positions 1-4. In all cases the green signal lamp indicates when the retarder is braking.



No gas should be given when the retarder operating signal lamp is illuminated, to prevent overheating of the cooling system and unnecessary fuel consumption.

10 CRUISE CONTROL

Cruise control allows a previously programmed constant speed (within the engine capacity) to be maintained. This system comes into effect only at speeds above 30 km/h. Cruise control is operated using the control level as follows:

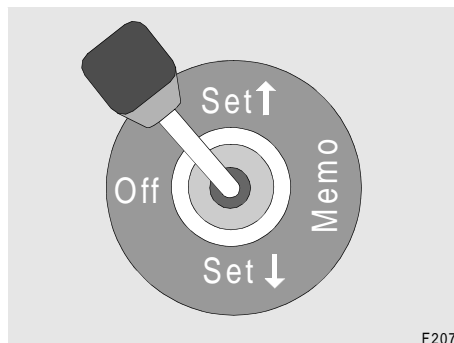

Set↑

The desired speed can be achieved and stabilised in different ways. You may accelerate using the gas pedal and put the lever in the "set↑" position after reaching the desired speed; or at low speeds (though above 30 km/h) you may hold the lever continually in the "set↑" position. With this method the vehicle will accelerate at 0.7 m/sec/sec until the operating lever is released.

If the gas pedal is used to provide rapid acceleration during an overtaking manoeuvre, the programmed speed remains programmed. The "temostat" system is put out of

action until overtaking is completed, whereupon the set speed is once again automatically maintained.

Set↓

Holding the operating lever in the "set↓" position lowers the set speed for the cruise control. When the new desired speed is reached the handle may be released, programming in this speed.

Memo

The system is designed so that the last speed remains programmed after the brake or clutch are operated, and can be called up again by putting the control lever in the "memo" position. The speed must be above 30 km/h.



It is advisable to use the "memo" position only when the same gear is selected as when the speed was programmed.

The memory is cleared when the engine is switched off, and the desired speed must be re-programmed.

"Off" position.

Placing the operating lever in the "off" position switches off the cruise control function.

The system also switches off if the brake pedal, clutch pedal or engine brake are depressed, or if the retarder or parking brake are operated.

Hand gas

Hand gas may be selected when the vehicle is stationary with the hand-brake on and the automatic handle in neutral.

Operating "memo" causes the stationary engine speed to be raised to 1200 rpm.

By using "set↑" or "set↓" the rpm may be raised or lowered by 25 rpm.

By operating "set↑" or "set↓" continuously, the minimum (750 rpm) or maximum (2000 rpm) engine speed can be reached steplessly.

Hand gas can be switched off by placing the operating lever in the "off" position.

Hand gas also switches off if the brake pedal or clutch are depressed, or if the retarder or parking brake are operated.

Futurair system controls

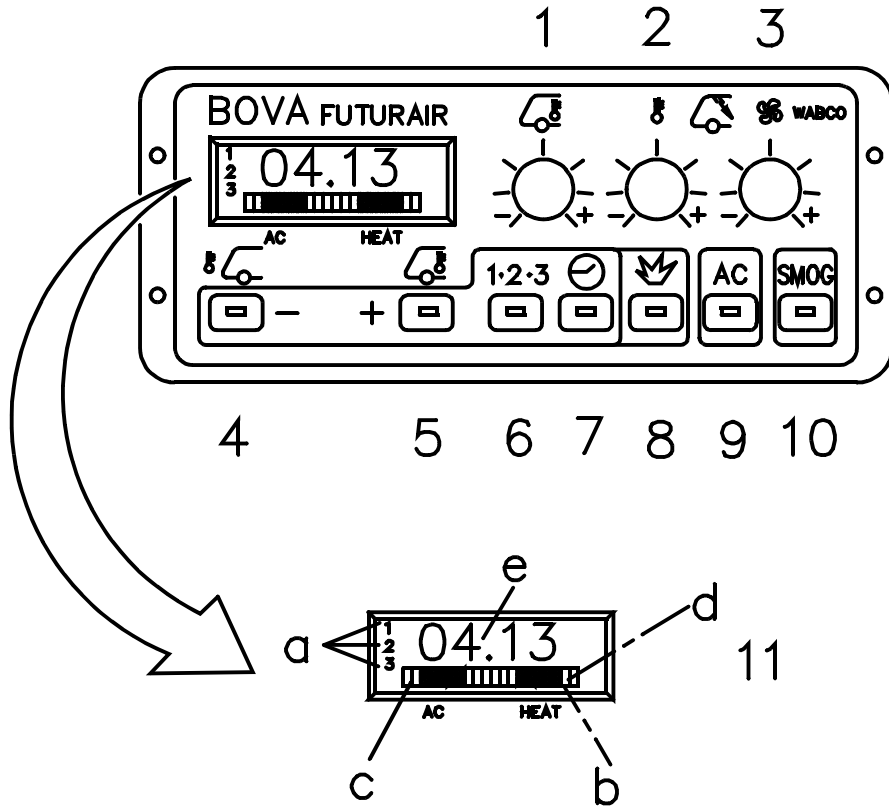

11 CLIMATE SYSTEM CONTROLS

General

The Futurair system operates only when the master switch Futurair climate system page 41 is in position 1 (automatic).

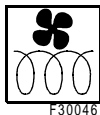

- 1 Setting the desired interior temperature (adjustable between 18 °C and, to the right, 28 °C). This setting varies according to the outside temperature. At the middle setting (the so-called comfort setting) the interior temperature may range between 23 °C and 27 °C.
- 2 The temperature of the air coming from the ventilation ducts above the passenger's heads can be raised or lowered by 2 °C with respect to the set interior temperature (1).

3 The velocity of the air coming out of the ventilation ducts above the passenger's heads can be raised or lowered by 15% with respect to the automatically selected velocity.

4 Call up outside temperature

5 Call up the interior temperature in the following sequence: interior temperature front, then interior temperature rear.

4+5 Depress briefly: erases an error code from the display
Depress for longer than 3 sec: the display shows a position between -8 and +8, which accords with a temperature difference of -2 °C to +2 °C.

6 Programming the preheater. 3 different times for the preheater to start up can be input. By operating pushbutton 6 one of the three times previously input can be called up to serve as the switch-on time. Once called up this time can be adjusted using key 4 (-) or key 5 (+). By selecting the fourth position (no number displayed) using button 6, the preheater is no longer programmed. The preheater cuts out automatically as soon as the set temperature is reached, and is under thermostatic control thereafter. The preheating period is limited to 60 minutes. When the preheater is programmed the lamp in key 6 will be brightly lit.

7 Setting clock time normally visible on the display. The digital clock can be set by simultaneously pressing key 7 and 4 (-) or 5 (+). Minutes can be set precisely by pushing the buttons briefly. Holding keys 4 or 5 in for a longer period accelerates the setting.

8 The lamp in this key will be illuminated brightly if the preheater is switched on. Pressing this key switches off the preheater.

9 This lamp will be illuminated brightly when the air conditioning is set on automatic. Pressing this key switches off the air conditioning.



8 & 9: the preheater is normally controlled by the Futurair system. Pressing key 8 or 9 suspends this automatic function. Turning the Futurair master switch off and on again will allow the

system to function automatically again.

10 Recirculating the interior air. Use when in tunnels or automatic vehicle washing machines. This function is suspended automatically after 10 minutes.

11 Display

a Preprogrammed times

b "HEAT" bar: lights up when the underfloor heaters are on

c "A.C." bar. Lights up when air conditioning is on.

d If the outside temperature is below +3°C, the outside temperature is displayed and an audible signal sounds for 5 seconds

e Clock display

If a fault occurs a fault code is displayed. See the Futurair documentation for an explanation of the codes. The code can be erased by briefly and simultaneously pushing keys 4 and 5. The code will reappear when the ignition is switched on, until the fault is repaired. In the case of a fault the system will select default setting.

12 AUDIO AMPLIFIER

See the supplier's documentation for operating instructions.

13 RADIO CASSETTE

See the supplier's documentation for operating instructions.

14 NAVIGATION SYSTEM

See the supplier's documentation for operating instructions.

15 ASHTRAY

The ashtray is removable

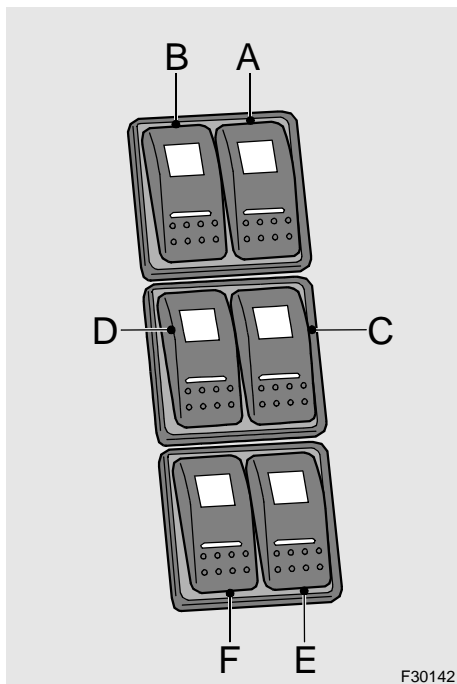

16 SWITCH GROUP

A Kneeling (option GB)

After applying the parking brake you can enable the kneel function of switch (B) by pressing this switch (A).

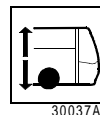

B Raising/kneeling (option GB)

After pressing switch (A) you can kneel the front of the vehicle by pressing the lower half of switch (B). To raise the vehicle press the upper half of the switch.

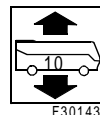

A Raising/kneeling separately (Only in combination with switch B)

A choice can be made between raising the front and/or the rear of the vehicle using this switch: The selected action will be carried out by operating switch B.

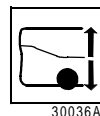

Depressing the upper half selects raise or kneel front.
 Depressing the lower half selects raise or kneel rear.
 Middle position switches off separate front/rear raise/kneel function.

B Raise/kneel control

The air suspension can be adjusted in two directions, up or down, as seen from the neutral driving position. Both alternatives are not always built in.

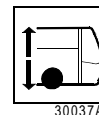

The raise/kneel switch has three positions, with the neutral position in the middle.

The raised position is mainly used to create more ground clearance, which may be required for example when boarding a ferry.

The lowered position facilitates the entry of passengers.



When raise/kneel is in operation, the yellow lamp on the dashboard is illuminated and the vehicle speed is limited to a maximum of 10 km/h.

C Warning lights (red)

This button simultaneously operates all the vehicle's direction indicators, both left and right, and also the indicators on any trailer connected to the trailer connector.

This function is always available, even when the ignition or master switch is off. The lamp in the switch flashes together with the green indicator signal lamp.



F30113

D Hostess call

Hostess call function switch.

When the hostess function is switched on, the lamp in the switch will illuminate if a passenger pushes the call button above his head. A buzzer will also sound for a few seconds. The lamp in the button above the passenger's head will also be illuminated until it is pressed again.

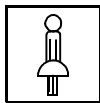

F30144

D Bell pushes

Switching the bell pushes on and off. If the passenger presses the bell push a buzzer will sound for a few seconds.

The lamp in the switch will also illuminate. This lamp will be extinguished when the entry door is opened.



F30073

E Option

F Option

17 CIGAR LIGHTER

Push the cigar lighter in. It will spring out again when it is sufficiently hot. Remove it from its holder.

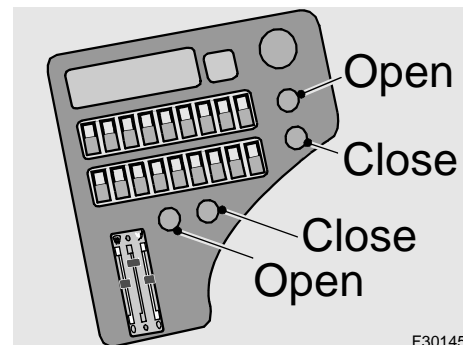

F30145

18 FRONT DOOR OPERATION

19 CENTRAL DOOR OPERATION

In compliance with legal requirements the vehicle is provided with a main (passenger) door as well as an emergency door.

The doors may be operated in a variety of ways, depending on the version, the requirements in the country of delivery and customer requirements. Various safety features may also be connected to the door operating system.

The doors are provided with emergency handles to allow them to be opened in an emergency. Various

handle designs are supplied, and the handles are to be found in a variety of locations on the door

The emergency pneumatic valves allow the system to be depressurised so that the door can be opened by hand. Once this has been done the door should be opened again pneumatically as soon as possible by using the switches on the dashboard or the emergency control in the entry and returning the emergency valve to its original position. Otherwise the door will close extremely rapidly on its next operation!

In most cases there is one emergency valve inside the vehicle and one outside. All doors can also be mechanically locked from inside or outside the vehicle.

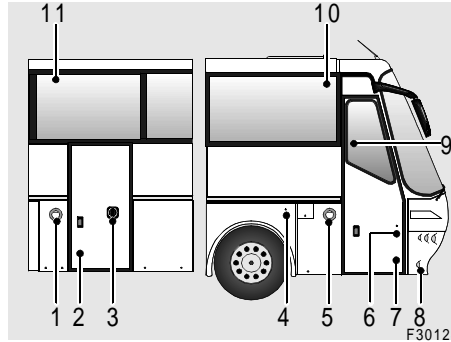

1/5	Pneumatic emergency valve
2/7	Pneumatic emergency valve in entry door (interior)
3	Mechanical locking, middle door
4	Electrical external lock
6	Mechanical locking, front door
8	Pneumatic emergency valve under head lamp corner
9	Mechanical emergency lever on B-rail (interior)
10/11	Pneumatic emergency valve in air duct (interior)



The driver must check at the start of the journey that all doors are unlocked and the handles are accessible.



Before the start of the journey the driver must point out the various emergency exits and their operation to the passengers.

20 SWITCH GROUP

A Mirror adjustment

Mirrors can be adjusted electrically, provided the master switch and ignition are on, by moving the knob left or right, up or down as necessary.

Turning knob to the right operates right mirror.

Turning knob to the left operates left mirror.

B Master switch

Switches the whole electrical system off and on, with the exception of emergency and parking lights, tachograph and preheater.

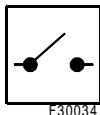

 Switching off the engine should be performed using the ignition key. The master switch should only be switched off once the ignition is off.

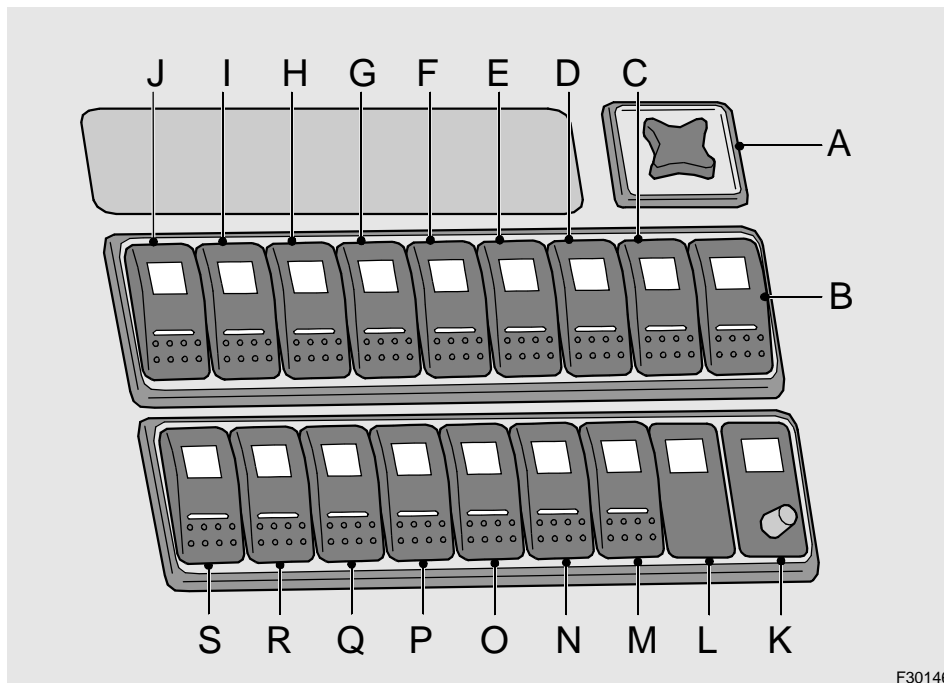

C Futurair climate system

The Futurair system is controlled with the aid of this switch.

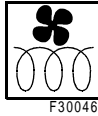

0	The Futurair system is switched off in this position.
1	This is the normal switch position. The Futurair display is illuminated and the system operates completely automatically.



For more detailed information about the Futurair system, please see the accompanying "Futurair" booklet.

D Retarder

Retarder master switch. Control of the retarder takes place via the control lever (see: Retarder operating handle page 47) and/or the foot brake pedal.



0	In this position the retarder operates fully automatically.
1	The retarder is switched off completely in this position.

E ASR system

The ASR system is always switched on, however operation of this switch allows an increase in the amount of slip in the driven wheels before the system intervenes.



The ASR (Anti Slip Regulation) system prevents the driven wheels slipping, both when driving away and during a journey, with the aim of optimising traction and directional stability.

Depending on the condition of the road surface, the ASR system reduces engine power and/or regulates braking pressure when excessive slippage is detected.

On consistent road surfaces control will primarily be by means of reduced engine power.



Operation of the ASR system is an indication that the road surface is slippery.

F Electrically operated driver's side window

To open or close the driver's side window, press the bottom or top of the switch



respectively. In case of an electrical fault in the side window operating mechanism, the window can also be opened or closed by hand.

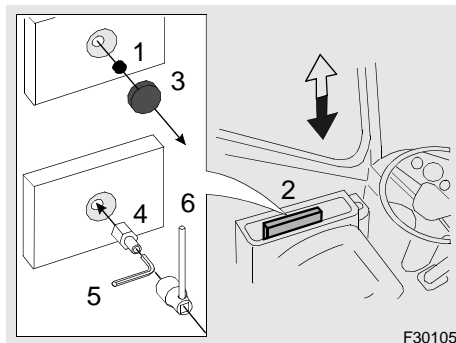

The operating procedure is as follows:

- Remove the lid of the driver's storage chest next to the driver's seat.
- Remove the rubber dust cover (3).
- Remove the rubber cap (1).
- Insert the nylon sleeve on the motor shaft with the allen key until a click is heard.
- Operate the the window using the socket spanner (6) on the nylon sleeve (4).



The tools mentioned above are included with the vehicle toolkit.

G External mirror heating

Switching the external mirror heating on and off. The signal lamp in the switch will illuminate brightly when this function is switched on.

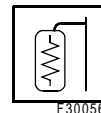

H Electrically heated driver's sliding window and/or window in service door

Simultaneous switching on and off of the driver's window and/or window in service door.

The signal lamp in the switch will be brightly illuminated if the function is switched on.



I Option

J Emergency operation of Futurair climate system

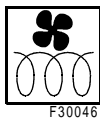

F30046

0	Emergency operation off
1	Emergency operation is on in this position, which means that maximum heating is provided by the underfloor heaters (only).



For more detailed information on the Futurair system, see Emergency operation of the FUTURAIR system page 89 or the accompanying "Futurair" booklet.

K Front heater

The speed of the front heater fan can be steplessly adjusted by turning the knob.

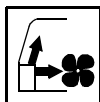

F30045

L Brake lining wear



F30147

The vehicle is provided with brake lining wear indicators. The relevant lamp will illuminate when one of the brake linings is close to wearing out.



The presence of these indicators does not take away the requirement for inspection of the brake linings. Regular checking remains essential.

M Option

N Option

O Option

P Option

Q Option

R Option

S Option

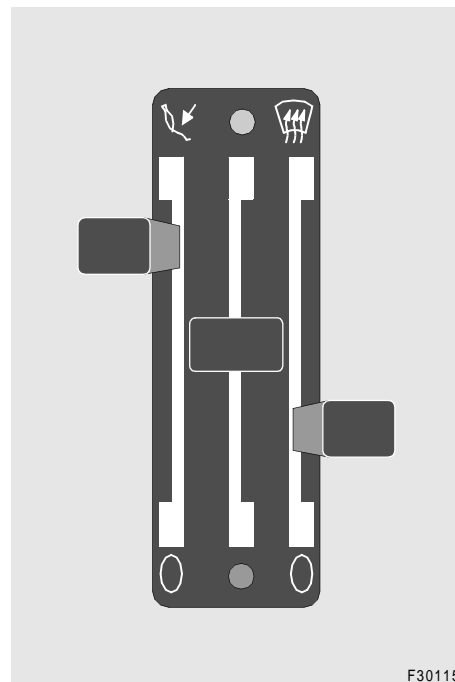

F30115

21 FRONT HEATER OPERATING SLIDES

- Left-hand operating handle: regulates air stream to the dashboard underside (including driver's feet).

- Middle operating handle: set air temperature (red = hot, blue = cold).
- Right-hand operating handle: regulates air stream above the dashboard (including wind-screen).



The fan speed can be adjusted by means of the heater control knob.

22 GEAR LEVER

A variety of gearbox options are fitted. See the supplier's documentation provided for operating instructions.

23 ACCELERATOR PEDAL

24 BRAKE PEDAL

The vehicle is equipped with an ABS braking system, and a signal lamp showing the letters ABS is provided on the instrument panel.

This lamp will illuminate when the master switch and ignition are switched on and will be extinguished after a few seconds.

The ABS function is activated only at the moment that one or more wheels lock and the vehicle threatens to skid. At that instant the ABS system will allow the braking force on the locked wheel to decrease until the wheel in question begins to rotate again and the grip on the road surface returns. The braking force is then immediately increased again until maximum braking is achieved or until the wheel in question locks up again, when the cycle described is repeated.

In this way the vehicle remains under control by means of "cadence" braking.



If the signal lamp indicates that the ABS system is defective, the vehicle will behave as if no ABS system was installed.

The normal braking system therefore remains intact.



There is now a possibility of the wheels locking with powerful braking.

The ABS system has no effect on the compressed air system or on the parking brake.

25 CLUTCH PEDAL

26 ENGINE BRAKE

The engine brake is operated by depressing the knob on the floor next to the clutch pedal. When this knob is depressed the fuel injection is inoperative and the exhaust is choked.



Engine braking does not operate at engine speeds below 700 rpm.

27 STOWAGE SPACE

28 CLUTCH FLUID RESERVOIR

See "Technical data" section for fluid specifications.

29 SPOILER FLAP OPENING HANDLE

Pulling this handle unlocks and partly opens the spoiler flap. It can be opened further by undoing the catch inside the flap. The flap is then held by suspension belts.



In this position the spoiler flap can be used as a step, for example to reach the windscreen for cleaning.

The flap can be opened further by removing the suspension belts.



Do not operate the handle whilst travelling.

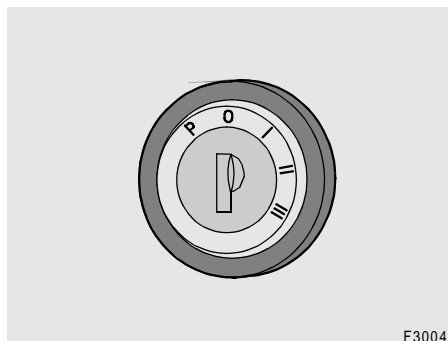

30 IGNITION KEY MECHANISM

The ignition key has four positions whose use is as follows:

P	The first position (fully anti-clockwise) is not connected. The key may be removed when in this position.
0	Ignition off. The key can be removed when in this position.
I	Ignition is connected: power is available for all electrical consumers that may be required during the journey. Preglow and automatic afterglow will operate if appropriate. The "glow" signal lamp on the dashboard will also illuminate during the preglow and afterglow. The engine may be started once the glow signal lamp is extinguished.
II+III	Operation of the starter motor



For position II and III the key must be turned to the right and held against the spring pressure.

Starting procedure



Ensure that the parking brake is on and put the gear lever in neutral.

- A Turn on master switch
- B Depress the clutch pedal
- c Turn on the ignition
Check whether the various warning lamps are illuminated. Check the status of the fuel meter and the coolant temperature gauge
- D In case of low outside temperatures the inlet manifold can be preheated with the aid of the preglow system. Wait until the preglow lamp has been extinguished
- E Turn the ignition key to position II or III to start.



If the engine starts, the engine speed may not be increased before the oil pres-

sure warning lamp is extinguished.



With extremely low outside temperatures the prewarmer (if fitted) may be used to warm up the engine for starting.

Turning off the engine

- A Operate the parking brake
- B Put the gear lever in neutral
- c Switch off the engine by switching off the ignition



Engines with automatic gearboxes can not be switched off unless the selector lever is in neutral

- D Switch off ignition
- E Turn off master switch

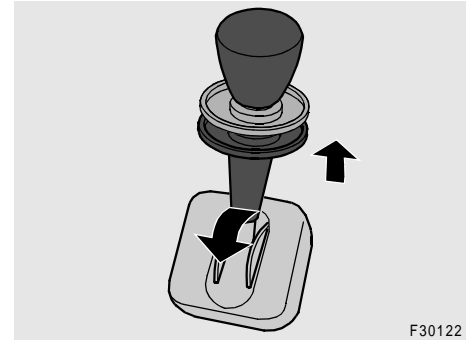

31 PARKING BRAKE

Apply the parking brake (handbrake) by pulling the ring upwards and moving the lever to the rear. In case of insufficient air pressure the signal lamp will illuminate and the parking brake can not be released.



Driving away must be delayed until the compressor has replenished the air.



The parking brake can also be used as an emergency brake.

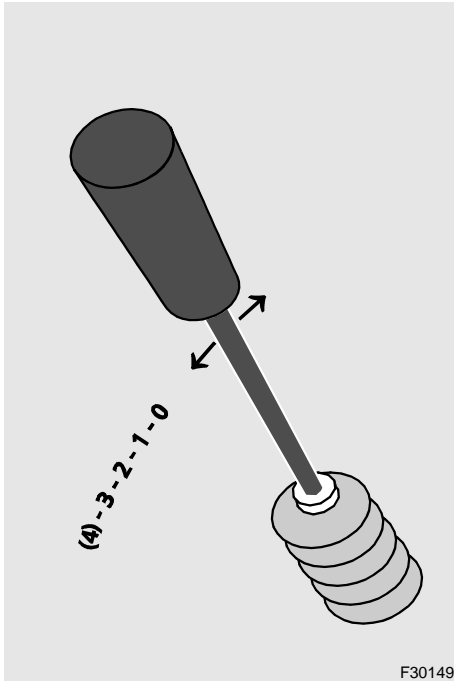

32 RETARDER OPERATING HANDLE

When the retarder is in operation, see: Retarder page 41, its braking effect can be increased in steps by moving the handle towards you. The

braking function is switched off in position 0.



With a manual gearbox the retarder has 4 steps, while with an automatic gearbox it has 3.

The green retarder signal lamp will illuminate when the retarder is activated.



No gas should be given when the retarder signal lamp is illuminated, to avoid overheating of the cooling system and unnecessary fuel consumption.



The red retarder signal lamp will illuminate in the case of a fault.

The retarder can also be operated in combination with the footbrake pedal (option).

Where foot operation is on, the retarder works to assist the main braking system while manual operation remains available.

As is usual, minimum use should also be made of the footbrake pedal during extended braking, for example during descents.



The retarder is cooled by means of the engine cooling system. Low engine speeds should be avoided by means of timely downshifting, particularly with low vehicle speeds. The full capacity of the cooling system is conserved by keeping to higher engine speeds.



Engine cooling operates at maximum capacity when the retarder is operated.

The operation and control of the retarder are described in more detail in the supplier's documentation provided with the vehicle.

For operation of the "Bremsomat" see: Bremsomat page 31.

33 SPEEDOMETER

The speedometer shows speeds in km/h in the outer ring and mph in the inner ring.



The speedometer reading may differ slightly from that shown by the tachograph. The tachograph reading shows the true value.

34 HGS FLUID RESERVOIR

See the "Technical data" section for fluid specifications.

SWITCHES WITH NO FIXED LOCATION

The switches described below are associated with optional equipment which may be installed.

These components may be found in a variety of locations on the dashboard, depending on customer's and national requirements and the number of options installed.

Heated fuel feed line

Operating this switch heats a section of the fuel feed line. This combats fuel waxing at extremely low outside temperatures.

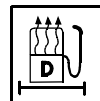

F30151

WC/foul water tank reservoir emptying

The WC/foul water tank can be emptied by means of this switch.

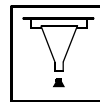

F30152



Empty only in a suitable location.

Film cabinet lighting

This switch operates the film/route cabinet lighting.

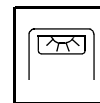

F30070

Driver's and guide's ventilation fan

Switching the driver's and guide's ventilation fan off and on

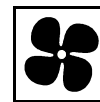

F30071

Kitchen equipment

Switching kitchen equipment on and off.



F30153

Top lights

Switching the extra top lighting off and on.

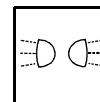

F30075

Gangway lighting

Switching gangway lighting on and off



F30076

School bus version: flashing lights



F30156

Driver's compartment air conditioning

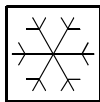

F30157

Heated driver's seat

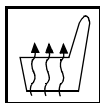

F30158

Luggage compartment (left) unlocking



30024A

Luggage compartment (right) unlocking



30026A

Trunk compartment lighting

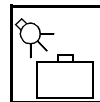

015

Monitor decoder

Switching on shows the navigation system display on the screen(s) inside the bus.



F30160

Transformer

Switches on 24V to 220V transformer

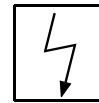

F30161

Low current protection

Switching on overrules low current protection

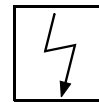

F30161

SIGNAL LAMPS WITHOUT FIXED LOCATION

The signal lamps described below relate to options which may be installed.

These components may be found in a variety of locations on the dashboard, depending on customer's and national requirements and the number of options installed.

Emergency/swinging door

This signal lamp illuminates if the emergency/swinging door is not correctly closed.



Automatic gearbox oil temperature

This lamp illuminates if the automatic gearbox oil temperature is too high.

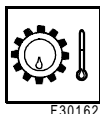

Central greasing

The "central greasing" lamp will illuminate when the automatic grease pump is in operation.



Drinking water tank empty signal

This lamp will illuminate when the water level in the drinking water tank is too low.

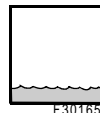

Foul water tank full signal

This lamp will illuminate if the level in the foul water tank is too high.



Toilet occupied lamp

This lamp will illuminate if the toilet door is locked.

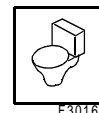

Master switch via ignition

Switching on and off of the whole electrical system (apart from emergency and parking lights, tachograph and preheater) using the ignition key.

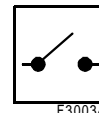

Gearbox high group

On versions with a manual 8 speed gearbox the "hare" symbol indicates that the high gear group is selected.

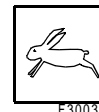

Gearbox low group

On versions with a manual 8 speed gearbox the "tortoise" symbol indicates that the low gear group is selected.

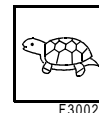

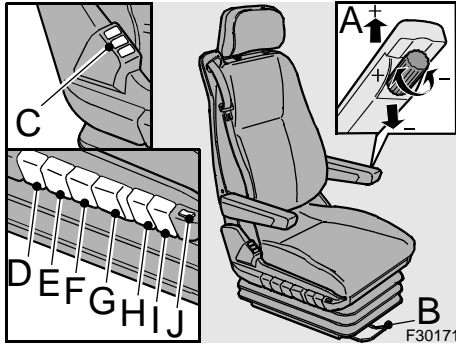

DRIVER'S SEAT



Set the seat in the desired position before starting to drive.

A: Armrest adjustment

The armrest height can be adjusted by turning the knob.

B: Height adjustment

Pull the clip upwards and set the seat in the desired position. The seat is adjustable over a 180 mm range.

C: Lumbar support and side wing adjustment

The air cushions fitted in the back support can be filled (+) or emptied (-) by pushing on the top or bottom half of the switch.

D: Adjustable vertical damping

E: back support adjustment

Pull the hand grip upwards and place the back support in the required position.

F: seat height adjustment

Pull or push the hand grip up or down to place the seat in the desired position. The seat can be adjusted over a 100mm range.

G: Seat inclination adjustment

Pull the hand grip up to place the seat in the required position. Releasing the grip will lock the seat.

H: Quick lowering

Push the hand grip down until the seat is lowered to its lowest position. Useful when getting in or out. When the hand grip is returned to its previous position the seat will return to its previous position.

I: Seat cushion depth adjustment

Pull the hand grip upwards and place the seat in the desired position.

J: Seat heating

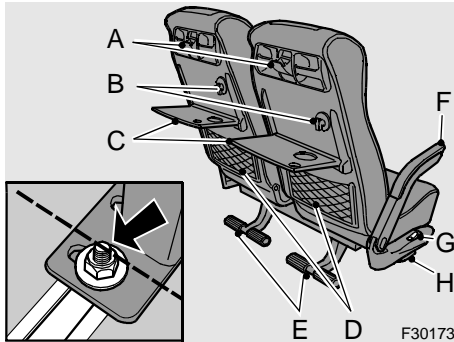

PASSENGERS' AREA

Passenger seats

The seats fitted in the vehicle may vary from those described here, depending on the chosen option.



Fit the passengers' seats using the correct torque.

- A Ashtrays, removable for easy cleaning.
- B Knob to secure hinged table.
- C Hinged table with space for drinking-glass.
- D Magazine rack
- E Footrest, adjustable by moving first up, then down.
- F Armrest next to aisle, folds away by swinging first upwards, then down.
- G Knob (on aisle side) and handle (on window side) for back support adjustment. The back support can be adjusted by 35° to 45° depending on the version fitted.
- H Knob for sideways adjustment of the aisle side seat.

Torque settings for passenger seat mounting

Kiel	
Gangway side	28 ± 3 Nm (M8)
Side wall side	28 ± 3 Nm (M8)

Vogel	
Gangway side	35 Nm (M10)
Side wall side	28 Nm (M8)

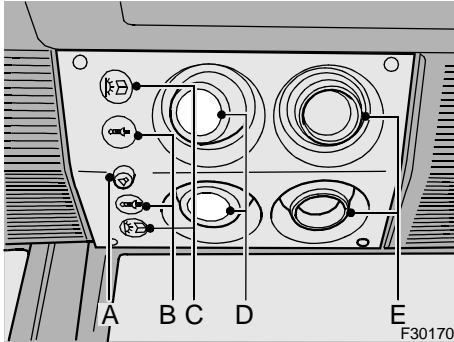

Personal setting units

Above each seat is a unit allowing ventilation and reading lamps to be adjusted to personal preference. As an option, a speaker, stop and hostess call buttons can be fitted to each personal setting unit.

- A The volume for each speaker can be adjusted using the (optional) rotary knob.
- B The (optional) hostess call switch can be operated by the passenger only when permitted by operation of the dashboard switch, see: Hostess call page 38.
If permitted, the lamp in the switch will illuminate if the passenger pushes the button above his head. A buzzer will also sound for several seconds. The lamp in the push-button above the passenger's head will continue to be illuminated until it is pushed again.
- C Operation of this switch turns on the relevant reading lamp.
- D Directional reading lamps
- E The ventilator mouths may be turned to open or close them and also directed according to preference.



3 SAFETY REQUIREMENTS AND EMERGENCY PROCEDURES

GENERAL	57
ROOF HATCHES	57
OPERATION OF PASSENGER AND MIDDLE DOOR	58
FIRE EXTINGUISHER	58
SAFETY BELTS	59
FIRST AID KIT	59
HAZARD WARNING LIGHTS	60
EMERGENCY HAMMERS	60
EMERGENCY PROCEDURES	60

Futura

GENERAL

The driver should adequately inform the passengers about emergency procedures, and ensure that all emergency exits are unobstructed before departure.

In an emergency the driver and/or the passengers may leave the vehicle via the doors, windows or roof-hatches.

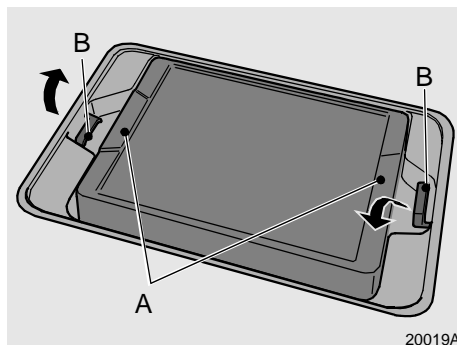

ROOF HATCHES

The vehicle is provided with two roof-hatches.

The roof-hatches have a ventilation position, and can be removed completely if needed as an emergency exit.

Ventilation position

The roof hatch can be opened fore and aft for ventilation purposes by pushing (A) to the outside. To re-close the hatch, pull (A) towards the inside. The roof hatches may be placed in the ventilation position when in motion, but if only the front ventilation position is used, the speed should not rise above 100 km/h.

Removal/Opening

In case of emergency the roof hatches can be removed by turning the handles (B) in the direction of the arrow. The hatch can then be thrown out. The hatch remains attached by a safety strap.

In case only handle B at the rear of the hatch is turned the hatch can be opened until 100°.



When installing, the hatch has to be locked with the help of handles (B). To enable this locking action you have to pull (A) firmly towards the interior!

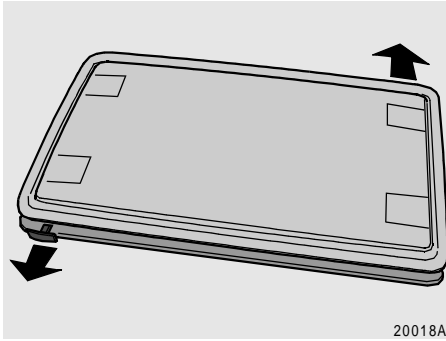

OPERATION OF PASSENGER AND MIDDLE DOOR

Passenger and central door

The passenger and centre doors are opened by means of:

- Dashboard switches.
- The emergency equipment near the steps at eye level.

In case of emergency the hatches may also be removed from outside pulling the lever.

FIRE EXTINGUISHER

The fire extinguisher is located behind the driver's seat, and is provided with a pressure gauge, showing whether it remains in good condition. Ensure that the condition of the fire extinguisher is checked annually. If the extinguisher is used it must be refilled as soon as possible.

SAFETY BELTS

The driver's seat is provided with triple point anchorage safety belts. The passenger and hostess seats are provided with double anchorage point safety belts.

 **It is your duty to ensure that the passengers use the safety belts properly!**

Fastening

Insert the clip into its housing. When a clear click is heard, the belt is fastened. It is important for safety reasons that the belt fits snugly against the body.

The belt must not be crooked or twisted.

The hip belt must sit low (ie not above the stomach).

Unfastening.

Push in the red knob on the housing. Ensure that inertia reel belts are rolled up without the belt being twisted.

Locking inertia reel belts.

Normally inertia reel belts are free to move.

The belt locks because of:

- Pulling the belt out too fast.
- Braking and accelerating, and when the vehicle tilts excessively to one side.
- On bends.

Inspection

Check regularly that the belts are in good condition.

The locking function of inertia reel belts can be checked by giving them a short tug.

The belt should lock and not be able to be withdrawn.

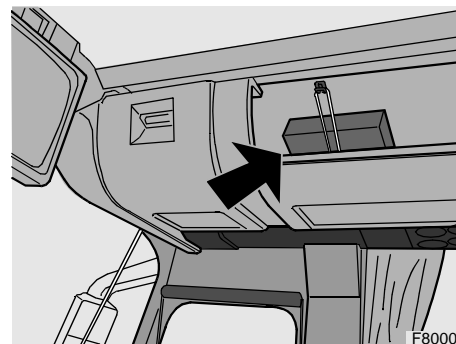

FIRST AID KIT

The first aid kit is located above the driver on the luggage rack. Ensure that you always have a complete first aid kit (obligatory in some countries).



Replace any of the contents as soon as they are used.

HAZARD WARNING LIGHTS

The hazard warning lights must be used if you are forced to stop or park in a way that obstructs or endangers other traffic.

The hazard warning lights are turned on with switch: Warning lights (red) page 38.



Requirements for the use of warning lights vary from country to country.

Hazard warning triangle/warning lamp

Place the warning triangle or warning lamp (in the toolkit) at least 30 metres behind the vehicle in case of danger.

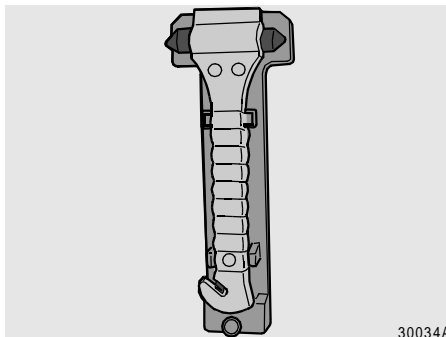

EMERGENCY HAMMERS

In an emergency these hammers may be used to break glass or to cut through a safety belt.

The hammers are located by the rear windows.

Break the seal and use the sharp point against the window glass, preferably not in the middle.



Take account of the double glazing.

EMERGENCY PROCEDURES

Even a vehicle in good condition may be involved in an emergency, a breakdown or an accident. This almost inevitably leads to dangerous traffic situations, since the vehicle may not come to rest in a safe location.

The behaviour of the driver can contribute a great deal to damage limitation. Situations vary too much for a standard solution to be given, but there are common features and the following rules can generally be applied:

- First ensure your own safety, then that of the passengers.

- Calm the passengers.
- Watch out for the other traffic.
- Be careful where you stand and walk.
- Watch out for the release of hazardous substances.
- Act quickly and decisively, but remain calm and avoid panic reactions.
- Prevent accidents and the escalation of accidents.
- Ensure that other road users are warned, for example by hazard warning lights, the vehicle's own lighting, the hazard triangle or similar.
- Switch off the engine and turn off the master switch.
- Prepare fire extinguishers if appropriate, extinguish any fires which may break out.

Notify the emergency and rescue services if necessary.

Assist any injured persons.

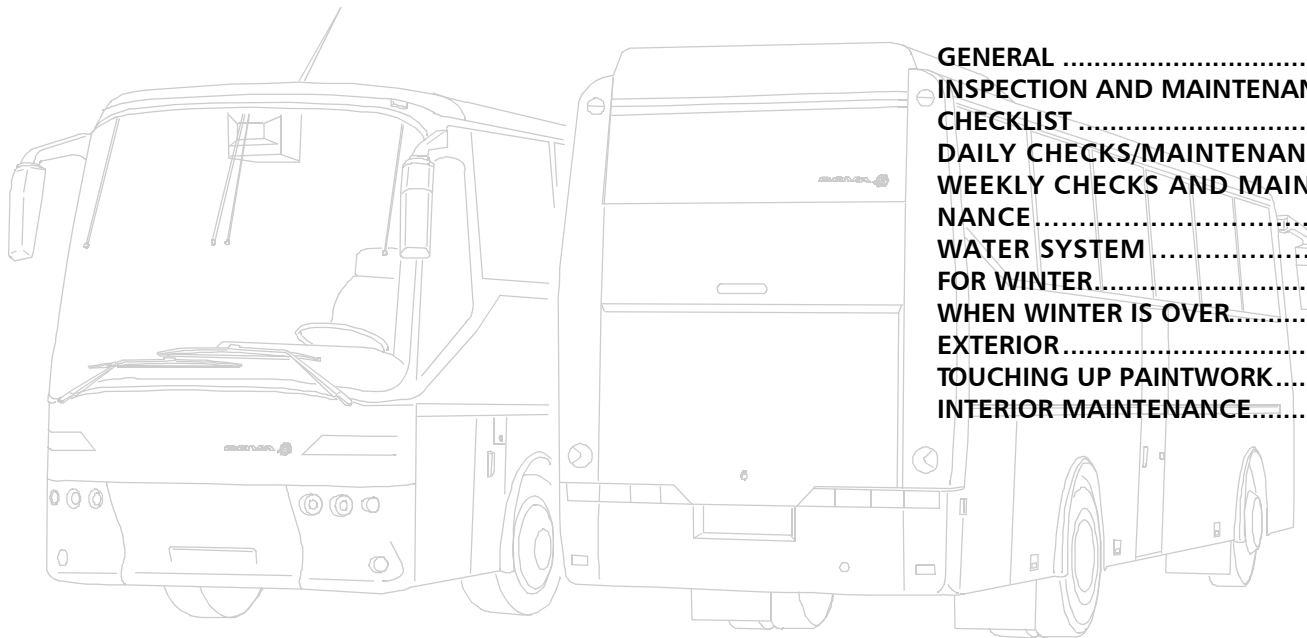

4 MAINTENANCE

- GENERAL 65
- INSPECTION AND MAINTENANCE CHECKLIST 66
- DAILY CHECKS/MAINTENANCE 68
- WEEKLY CHECKS AND MAINTENANCE 69
- WATER SYSTEM 74
- FOR WINTER..... 74
- WHEN WINTER IS OVER..... 76
- EXTERIOR..... 76
- TOUCHING UP PAINTWORK..... 78
- INTERIOR MAINTENANCE..... 78

Futura

GENERAL

The durability, safety, depreciation and reliability of the vehicle is to a large extent dependent on the way it is cared for and on the regular performance of the maintenance prescribed by BOVA.

The driver's driving style and his care of the vehicle have a direct influence on the vehicle's condition.

The driver can often give the workshop information which is valuable for good maintenance.

The vehicle should be maintained at the intervals given in the BOVA Futura maintenance manual. However if the vehicle has to operate in dusty areas or under difficult conditions the frequency of maintenance should be increased.

The maintenance discussed under this heading refers to activities the driver himself can carry out.

A checklist is provided listing the points to be covered by the driver.

Opening engine compartment and bumper



**Beware of moving parts.
Switch off the engine before
opening the bonnet.**

The bonnet can be opened by giving the key a quarter turn and pulling the bonnet open. The bonnet swings up, assisted by two gas springs.



**Should the key break off in
the lock, the bonnet can also
be opened by pulling on the
handle which protrudes
below the lock (this is only
possible if a key is in the
lock).**

If the bonnet is in its highest position, one of the two gas springs must be mechanically locked by pushing the distance sleeve against the spring housing (A).

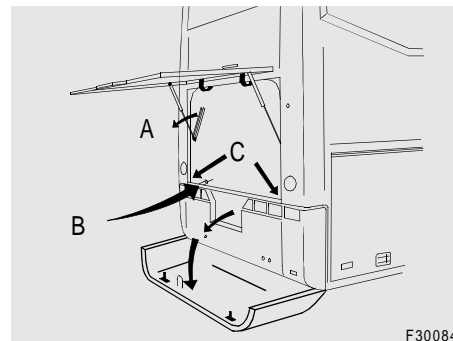

F30084

The bumper can also be swung down for operations such as the replacement of a V-belt:

- Loosen nuts C. The bumper is held by a catch (B).
- The bumper can also be completely removed by rotating it to the bottom and lifting it out of the rotation point.



**Prevent paint damage and
ensure that the electrical con-
nectors of the bumper lights
are disconnected (in the
white junction box).**

INSPECTION AND MAINTENANCE CHECKLIST



Maintenance activities can be checked off on a copy of this list.

	Daily	Weekly
Engine compartment		
• Check engine oil level*	<input type="checkbox"/>	<input type="checkbox"/>
• Check fluid level of the fan's hydraulic system*		<input type="checkbox"/>
• Check coolant level*	<input type="checkbox"/>	<input type="checkbox"/>
• Check power steering fluid level*		<input type="checkbox"/>
• Check air filter*		<input type="checkbox"/>
• Check V-belts	<input type="checkbox"/>	<input type="checkbox"/>
Underbody		
• Drain water from air tanks*		<input type="checkbox"/>
• Check transmission, rear axle and engine for leaks		<input type="checkbox"/>
Sides		
• Check the wheelnuts visually		<input type="checkbox"/>
• Check tyre pressure		<input type="checkbox"/>
• Check tyres and rims for wear and damage	<input type="checkbox"/>	<input type="checkbox"/>
• Remove stones from the tread and from between the double tyres	<input type="checkbox"/>	<input type="checkbox"/>
• Check the closure of all side flaps	<input type="checkbox"/>	<input type="checkbox"/>
Front		
• Check windscreen and headlamp washer reservoirs*		<input type="checkbox"/>
• Check condition of windscreen wipers		<input type="checkbox"/>
• Check spare tyre pressure		<input type="checkbox"/>

	Daily	Weekly
Interior		
• Check seats for secure mounting and covers for damage and soiling		<input type="checkbox"/>
• Check Hydraulic Gearshift System fluid*		<input type="checkbox"/>
• Check clutch fluid*		<input type="checkbox"/>
• Check front box dust filter.		<input type="checkbox"/>
• Check seat belt security and reel mechanisms		<input type="checkbox"/>
• Check if first aid kit, emergency hammers and fire extinguisher(s) are present	<input type="checkbox"/>	<input type="checkbox"/>
• Check if doors, emergency exits and emergency valves open and close	<input type="checkbox"/>	<input type="checkbox"/>
• Check spares, jack, tools and hazard triangle are present	<input type="checkbox"/>	<input type="checkbox"/>
Roof		
• Check roof unit dust filters*		<input type="checkbox"/>
Electrical system		
• Check all exterior lights (parking lights, main and dipped beam, brake lights, fog lamps, reversing lights, clearance lights, registration plate lights, indicators and alarm lights)	<input type="checkbox"/>	<input type="checkbox"/>
• Check battery fluid levels*		<input type="checkbox"/>
• Check all interior lighting (main lights, dashboard, reading lamps and entry lighting)	<input type="checkbox"/>	<input type="checkbox"/>
• Check dashboard instruments and signal lamps for operation and correct signal before and after starting	<input type="checkbox"/>	<input type="checkbox"/>
• Check operation of windscreen wash/wipe and horn	<input type="checkbox"/>	<input type="checkbox"/>
In freezing conditions		
• Drain water tank, boiler, coffee machine and WC water supply	<input type="checkbox"/>	<input type="checkbox"/>
• Windscreen washer antifreeze in reservoir	<input type="checkbox"/>	<input type="checkbox"/>
• Antifreeze in chemical toilet	<input type="checkbox"/>	<input type="checkbox"/>

*These operations are discussed in more detail in the following pages

DAILY CHECKS/MAINTENANCE

Carry out daily checks and maintenance as follows: Inspection and maintenance checklist page 66.

Open the engine compartment see: Opening engine compartment and bumper page 65.



Preferably, switch off the engine before opening the engine compartment.

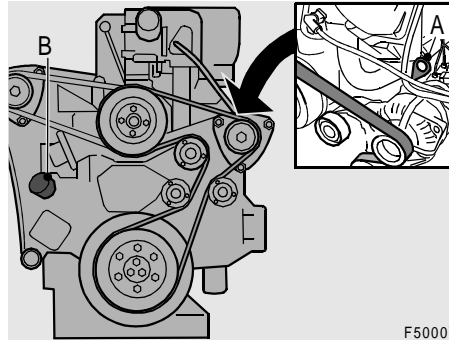

Engine oil level

- Ensure the vehicle is standing on level ground.
- Turn off the engine and wait 5 minutes minimum.
- Remove dipstick A from its housing
- Clean the dipstick with a lint-free cloth

- Insert the dipstick in its housing and wait a few seconds
- Remove the dipstick again and read the level: it should always be between the two marks.
- Add oil as necessary via the opening B.

Always use the correct oil.
Avoid overfilling.



Oil specification is in the technical data section.

The difference between full and empty engine oil levels is around 8 litres.

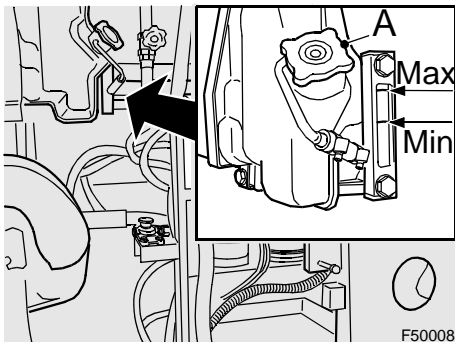

Coolant level

Check coolant level when the engine is cold.
If coolant level is below the minimum, checks for leaks must be carried out.



If the coolant is warm the cooling system is under pressure. In that case cover the filler cap with a thick cloth and remove it slowly and gradually, allowing pressure to escape. Then remove it completely.



Engine coolant contains harmful substances, so avoid skin contact.



To avoid damage to the engine block when adding cold coolant to a warm engine, add it slowly while the engine is running.

Remove filler cap A from the reservoir. Fill the reservoir to the maximum. See "Technical data" for the specification for coolant.

Bring the engine up to working temperature.
Switch off the engine and check the coolant level.

WEEKLY CHECKS AND MAINTENANCE

Carry out the following weekly checks and maintenance: Inspection and maintenance checklist page 66.

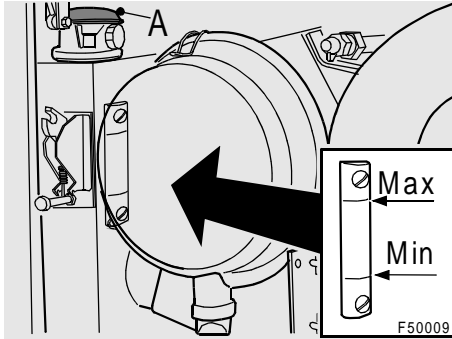

Hydraulic fluid

The fan drive has a reservoir for hydraulic fluid. Check that the fluid level is between the two marks. Fill as required via opening A.

⚠ Top up only with engine switched off, then check level with engine running.

For the specification for hydraulic fluid see "Technical data".

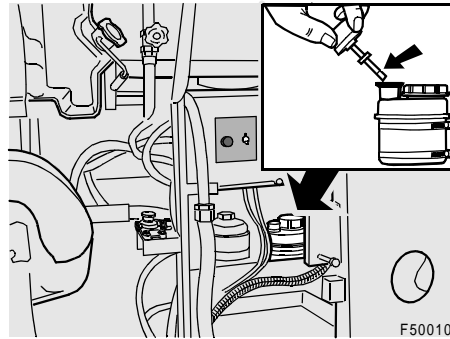

Power steering fluid

Check, with the engine stopped, that the fluid reaches around 2 cm above the upper marking on the dipstick. Add fluid as necessary. Start the engine (the engine can not be started when the bonnet is open). The fluid should reach the upper marking on the dipstick when the engine is running and the vehicle is stationary. For power steering fluid specification, see "Technical data".

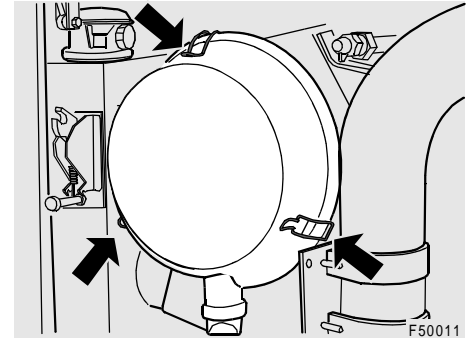

Air filter

Check the air filter for soiling and damage. If damaged it must be replaced immediately. If the air filter is dirty it may be cleaned by blowing from the inside with compressed air (maximum pressure 5 bar). Clean the filter housing before replacing the filter.

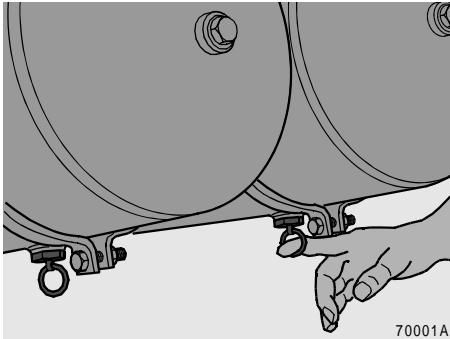

Brake system air dryer

Drain water out of the air tanks by pulling on the rings. The air tanks are best reached via the battery compartment on the underside of the coach. If more water is regularly drained off than has been usual, the air dryer filter element must be replaced (consult a BOVA workshop).

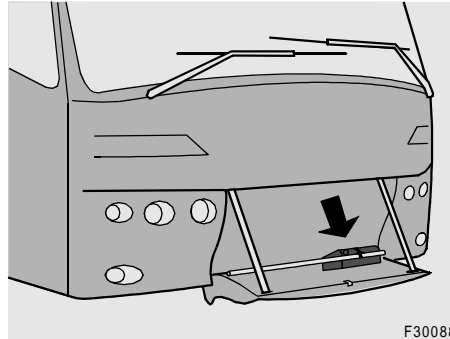

Screenwash reservoir

Check the screenwash reservoir and fill if necessary. Add screen-clean in summer. Add anti-freeze screen clean in winter.

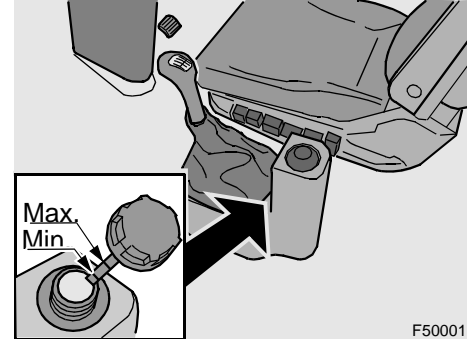

Hydraulic Gearshift fluid

Check the fluid level in the HGS reservoir when the engine is cold and at a normal outside temperature (around 20 °C). The fluid should be between the marks. Add fluid as necessary. For hydraulic fluid specifications see "Technical specifications".

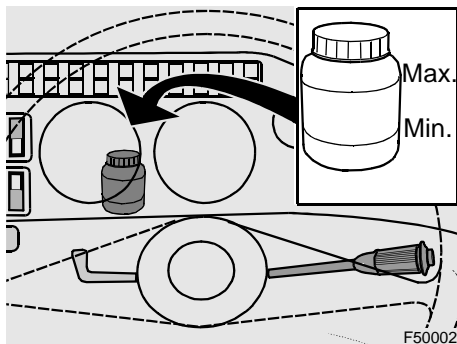

Clutch fluid

Check the fluid level in the clutch fluid reservoir.
 The reservoir is located behind the rev counter which is easily removed.
 The fluid level should be between the marks.
 Fill as necessary.
 For clutch fluid specification see "Technical data".

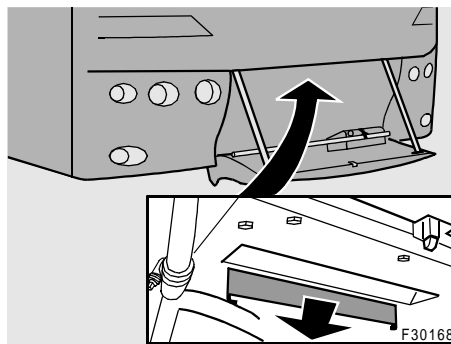

Front box dust filter

The dust filter in the front box is accessible via the spoiler hatch.
 A dust filter is only fitted in the front box if the "driver's airconditioning" option is fitted.
 Remove the hatch.
 Remove the filter housing cover (2 x 4mm bolts).
 Remove the filter.
 Clean or if necessary replace the filter.
 Clean the filter housing before replacing the filter.

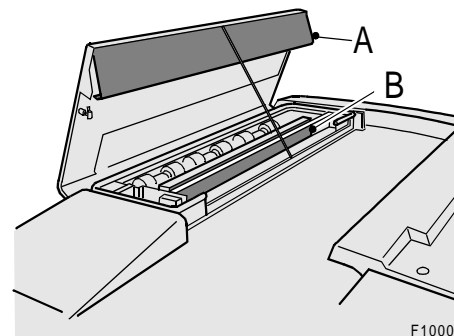

Roof unit dust filters

The dust filters are located in the roof units.
 Clean the area around the roof units.
 Open the roof units (8 mm Allen key).
 Remove leaves, twigs etc. from filter A and clean the filter.
 Clean the filter housing.
 Check and if necessary replace filter B.
 Check that filter A is correctly positioned when closing each roof unit.
 Close and lock the roof units (8mm Allen key).

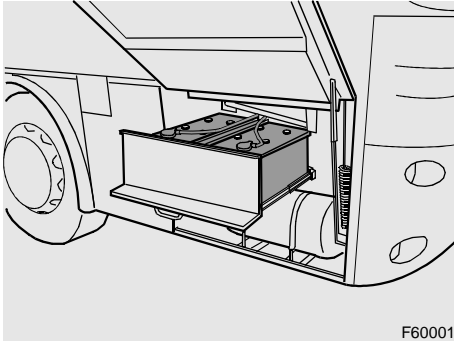

Battery acid is an aggressive fluid. Rinse with plenty of water if it contacts clothing, eyes or skin.

Check that the battery contacts and clamps are clean and well-greased. Grease them if necessary with acid-free vaseline. Don't forget to replace the battery carriage securing pins after these checks.

Central greasing

If central greasing is installed, the reservoir is located in the extra luggage compartment next to the engine compartment. Check the grease level in the reservoir. Fill as necessary.

Batteries

The batteries are located front right, behind a closeable flap.

Check electrolyte level: it must be around 5 mm above the plates. Refill as necessary with distilled water.

WATER SYSTEM



The owner of the vehicle is at all times responsible for the quality of the water used in the vehicle.

In order to reduce to a minimum the development of legionella bacteria, the following issues need to be considered:

Main water tank:

- Flush once a month with a disinfectant.

Extra (drinking-) water tank

- Inspect once a fortnight or inspect with every filling if the tank is not filled through the normal couplings, but through the inspection panel.
- In case of scale formation in the tank, it should be cleaned according to the aforementioned method.

Water conduits

As the hosepipes are rinsed out while cleaning the tank, a visual inspection of the hosepipes while filling the water tank should be sufficient.

Connected devices

- The temperature of the water heater should be adjusted to the maximum temperature (± 85 °C). Along with cleaning the tanks and the pipes, this will minimize the risk of infection.

Connecting a washing installation to the main water tank increases the risk of legionella infection.

FOR WINTER

Check anti-freeze content.

Check the anti-freeze content of the coolant.

If anti-freeze has not been added already, fill the cooling system with anti-freeze.



To avoid damage to the engine block when adding cold coolant to a warm engine, add it slowly while the engine is running.

Only use coolant, or if appropriate, anti-freeze, which satisfies BOVA specifications: see "Technical data". No variation is permissible because of the aluminium radiator fitted.

Follow the manufacturer's instructions for the correct composition of coolant when adding anti-freeze.

Screenwash/headlamp wash reservoir

Add winter screenwash.

Air conditioning

We advise that the side flap of the condenser compartment should have the winter cover installed to protect the area against salt and road grime. It is not possible to switch on the air conditioning system when the winter cover is in place.

Run the air conditioning system compressor regularly (around once a month) for several minutes to allow oil to be pumped around the system, preventing the seals from drying out.



Remove the condenser's winter cover during this operation.

Fuel

During the winter months the fuel suppliers often use additives to prevent paraffin deposits, which cause blockages.

In extremely low temperatures, or when no so-called winter fuel is available, a maximum of 20% kerosene may be added, **where this is permitted by law.**

Where that is not allowed by law, then a maximum of 20% lead free petrol may be added.

Where it is legally permitted, up to 0.5% methylated spirit may be added to prevent ice formation.

Fuel additives to prevent paraffin deposits have only a preventative effect. They are not suitable for dissolving the paraffin.



Ensure that a spare fuel filter is available so that the filter can easily be replaced in the event of blockages (also those caused by paraffin deposits), See: Replacing fuel filter page 87.

Batteries

The demands placed on batteries are much higher in the winter than in the summer, since lights, windscreen wipers etc are used more. The battery capacity also falls in low temperatures.

A poorly charged battery may freeze if it is extremely cold.

Check the charging status of batteries regularly and grease the terminals with acid-free vaseline.

Locks

Use special lock oil (teflon spray oil). Avoid the use of ice-melting sprays as these interfere with the proper operation of the lock.

Door and flap rubbers

To prevent freezing the various rubber seals should be rubbed with talc.

Kitchen and toilet water system.

Operating this switch disables the drinking water tank empty alarm.

The water can subsequently be pumped out of the tank by operating the valve in the vehicle.

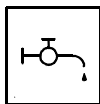

 **After emptying the tank, reset the switch so that the alarm resumes operation, preventing the pump running dry.**

 **Make sure that all reservoirs and pipes are drained to prevent freezing.**

WHEN WINTER IS OVER.

Cooling system

The anti-freeze mixture may be left in the system during the summer.

Screenwash/headlamp wash reservoir

It is advisable to add a cleaning agent to the water.

Air conditioning

Remove the winter cover from the condenser compartment side flap.

EXTERIOR

Washing

Wash the vehicle as soon as it is dirty in winter as salt and dampness easily cause corrosion.

Remove bird droppings as soon as possible from the paintwork! Bird droppings contain substances which attack and discolour paintwork. The discolouration can not be polished away.

 **Always wash the vehicle in a suitable place.**

You can wash the vehicle as follows:

Hand washing

- Carefully hose off the soiling from the underside of the vehicle (wheel arches, around mudflaps etc.).
- Hose down the whole vehicle to loosen the dirt. Avoid spraying directly into locks.
- Wash the vehicle using a sponge, with or without a cleaning agent. Use lukewarm water for preference, but avoid hot water.
- Dry the vehicle with a clean, soft chamois.

Washing with a high pressure jet washer.

Take care that the spray head of the jet washer does not come closer than 30 cm from the coachwork. Also, avoid spraying into or near the locks of the various hatches and doors and the engine compartment.

Cleaning in a vehicle washing machine.

The vehicle can be washed quickly and simply in a vehicle washing machine.

Bear in mind however that the vehicle washing machine cannot clean the vehicle as carefully and effectively as you can with a sponge and water. The car-wash brushes cannot reach into all areas.

Before entering the vehicle washing machine, ensure that any extra equipment is properly secured, or it may be pulled loose by the brushes.

Only wash the vehicle in a vehicle washing machine with clean brushes.



It is not recommended to use a vehicle washing machine for the first few months as the paint layers may not have sufficiently hardened.



Depending on the type of car wash it may be necessary to remove the mirrors.

Cleaning agents

Car shampoo, or 5 - 10 cl ordinary washing-up liquid to 10 litres of water.

Spotting on aluminium may be removed with car polish.

Never use polishing paste or steel wool.

Waxing and polishing

You should wax and polish the vehicle if you find that the paint has lost its gloss and normal washing doesn't restore the original gloss.

Normally the vehicle exterior will need polishing only after a year. You may apply wax before then.

Wash and dry the vehicle well before polishing or waxing.

Remove asphalt and tar spots with turpentine.

Stubborn marks may be removed with a fine car paint polish.

There are many brands of polymer wash materials on the market. These are easy to work with and give a hard and very glossy surface which protects the paint against oxidation, dirt and dulling.

TOUCHING UP PAINTWORK

General

Paint damage on metal parts must be dealt with without delay to prevent rust formation.

It is advisable to check the paintwork regularly, perhaps after each wash, to touch up any possible damage.

Small spots and scratches can be touched up with a paintbrush.

Larger areas of paint damage require special equipment and expertise. It may be advisable to have more major damage repaired by a specialist workshop.

Minor scratches and stone damage

If the chipping caused by stones has not penetrated to the metal, and undamaged paint is still present, you may paint directly over the spot, after polishing to remove dirt.

If the chipping has penetrated to the metal you must proceed as follows.

- Sand the damage area down to the metal and remove sharp paint edges with a sharp knife.
- Use a rust removal agent on the metal, wait for several minutes

and then wash well with water. Then rub dry. (this treatment is not needed on plastic substrates).

- Stir the primer well and apply it.
- When the primer has dried apply the top coat with a brush.

INTERIOR MAINTENANCE

General

Remove soiling as soon as possible before it has dried in.

Soiling should be dissolved away, rather than rubbed, scraped or removed with a hard brush. Always work from the edge of the soiling towards the middle.

Cleaning upholstery

The fabric upholstery of the seats can generally be cleaned with soap and water or detergent solution.

With difficult stains like oil, ice-cream and shoe-polish, a special cleaning agent may be used. Follow the cleaning agent manufacturer's instructions.

Use solvent cleaners sparingly. Excessive use of solvents may damage the foam plastic filling of the seats.

Cleaning curtains and seat covers

Curtains and seat covers can normally be washed in cold water.

If they are soiled they can be washed at 30 °C.

Bleach should not be used.

Use of washing powders may cause discolouration.

To keep colours uniform all curtains or covers should be washed together. Brushing covers is not recommended.

Cleaning plastic

Plastic parts should be cleaned with a lukewarm solution of synthetic cleaning agent.



Avoid the use of trichloroethylene, petrol and similar materials on plastics.

Cleaning carpets

Soak up as much as possible with clean cloths.

Vacuum around the affected area to avoid spread.

Dampen the affected areas with textile cleaning agent on a clean cloth.

Soak up the cleaning agent with a dry cotton wad. Repeat the process until the soiling is gone.

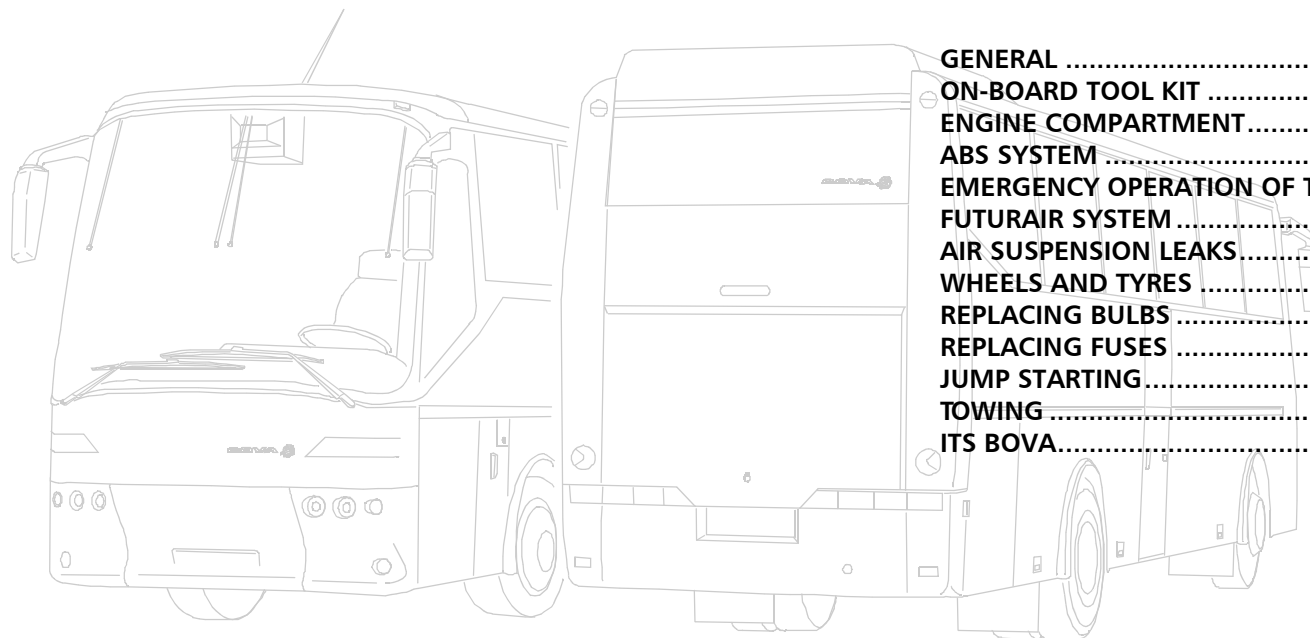

5 RUNNING REPAIRS

GENERAL	83
ON-BOARD TOOL KIT	84
ENGINE COMPARTMENT	85
ABS SYSTEM	89
EMERGENCY OPERATION OF THE FUTURAIR SYSTEM	89
AIR SUSPENSION LEAKS	91
WHEELS AND TYRES	92
REPLACING BULBS	95
REPLACING FUSES	96
JUMP STARTING	98
TOWING	99
ITS BOVA	102

Futura

GENERAL

Even if your care of the vehicle is exemplary, problems may still arise, such as a flat tyre, blown bulb or similar, which you will have to repair to continue the journey.

Safety



Before attempting to carry out repairs you must first ensure your own safety and that of the passengers. Stop the vehicle in a safe place and if necessary have the passengers assemble in a safe place near the vehicle.

Cleanliness

A clean working environment is of great importance when carrying out repairs, to prevent giving rise to the need for further repairs to damage caused by unnecessary contamination.

A clean and tidy work environment also improves safety. Also, you should leave the working area in the same condition as you found it.

ON-BOARD TOOL KIT

The vehicle is equipped with an on-board tool kit including:

	number		
Tool kit	1	wheel key	2
4mm drift	1	jack and foot	1
tommy bar	1	jackrod	1
wheelnut spanner	1	tyre inflation hose	1
open-end spanner 14 x 15	1	inspection lamp with plug	1
ring spanner 17-19	1	hazard warning triangle	1
open-end spanner 17-19	1	towing eye assembly (mounted behind the spoiler flap)	
ring/open-end spanner 18	1	square spanner	1
ring/open-end spanner 32	1	special spanner for hatches	1
Allen key 8 mm	1	4mm allen key, for hubcaps	1
cross-headed screwdriver	1	spare wheel puller	1
150 mm screwdriver	1	Lamp kit with fuses	1
75 mm screwdriver	1	If electrically operated driver's window then also:	
bench hammer, 400 g	1	removable sleeve	1
250 mm spanner	1	3mm allen key	1
combination pliers	1	cap spanner	1
water pump pliers	1		
10 compartment tool roll	1	The on-board tool kit is located in the extra storage compartment to the right behind the rear axle.	

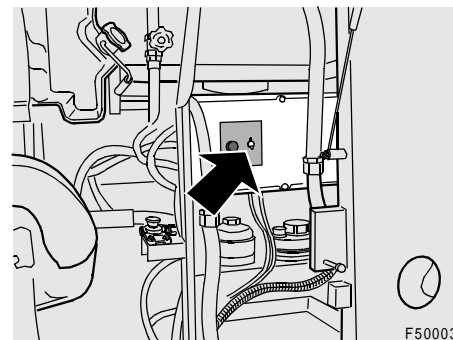

Inspection lamp connection

The 24 volt inspection lamp can be connected at two points in the vehicle.

Engine compartment:

The inspection lamp, without its plug, may be connected in the engine compartment as shown in the illustration above.

Cigar lighter

To connect the inspection lamp to the cigar lighter socket, fit the lamp's adaptor plug.

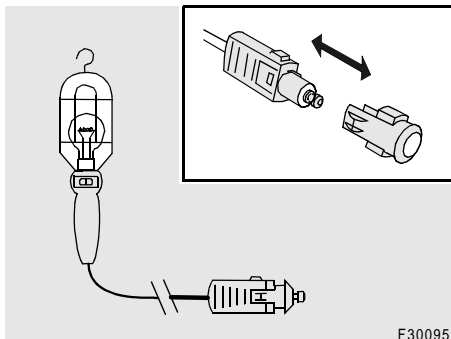

F30095

Plug

Fit the adaptor plug to the inspection lamp plug for use in the cigar lighter as illustrated.

ENGINE COMPARTMENT

Replacing V-belts



Always fit V-belts of the same design.



Where two V-belts are used together, both must be replaced together.

- Remove the multi-V belt, see: Replacing multi-V belt page 86.
- Release locknut (A) from stud.
- Release securing bolt (B) from water pump stud.
- Release securing bolts (C) and (D) from the dynamo.
- Release locknut (E) from adjuster (F)
- Turn the adjuster (F) so that the dynamo leans in the direction of the engine block.
- The V-belts may now be replaced.

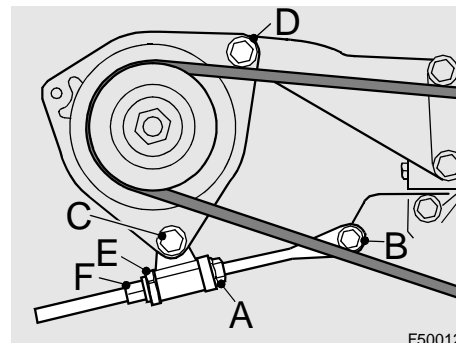

F50012

- Inspect the pulleys for damage, rust and contamination with grease.
- Fit and tension the new V-belts (see adjusting V-belt tension).



Check the adjustment of the new V-belts after the first 50 km and have the tension checked as soon as possible by a BOVA garage.

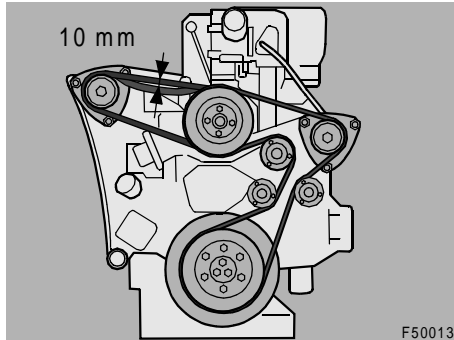

Adjusting V-belt tension

Remove fixing bolts and locknuts (see replacing V-belts).

Position the dynamo, by turning the adjuster until the correct V-belt tension is achieved.

A correctly tensioned V-belt can be deflected around 10 mm by light pressure at a point between the dynamo and water pump. Replace all nuts and bolts.

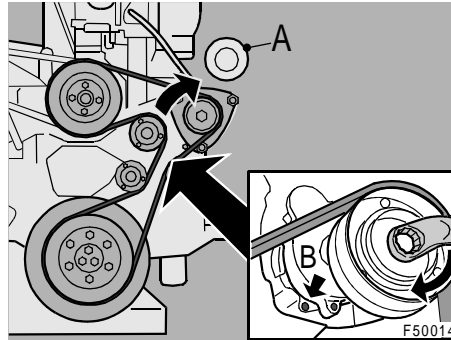

Replacing multi-V belt



Always fit a multi-V belt of the same specification.

- Disconnect the battery earth cable and remove the air conditioning belts. See: replacing air conditioning belts.
- Remove cover A and fit a suitable spanner to the automatic belt tensioner.
- Slacken the multi-V belt by turning the spanner against the automatic tensioning device's spring tension
- Place a drift at position B so that the spring tensioner is locked and

remove the multi-V belt from the pulleys.

- Inspect the pulleys for damage, rust and grease deposits.
- Fit a new multi-V belt.
- Remove the drift and cautiously allow the automatic belt tensioner to apply its pressure to the new multi-V belt.
- Check that the multi-V belt fits in all the pulley grooves.
- Replace cover cap A.
- Reconnect the battery earth cable.

Replacing airconditioning belts

The two belts for the airconditioning compressor can be removed by pushing the tensioning roller downwards with a lever.

Replacing 3rd dynamo V-belt.

Loosen the dynamo securing bolts. Move the dynamo towards the compressor using the adjusting mechanism.

The belt can now be removed.

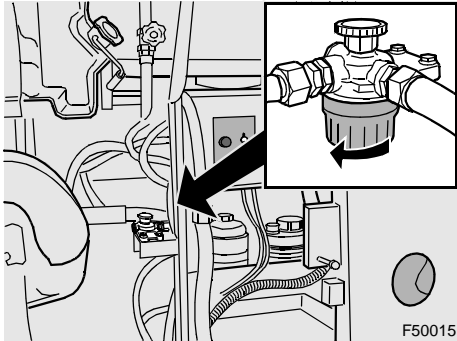

Replacing fuel filter



Diesel fuel is flammable and should not be exposed to open flame or other heat sources such as a hot engine. Catch any leakage in a suitable container.

Cleaning coarse fuel filter

The coarse fuel filter may need cleaning, for example because of wax deposits.

- Remove the lower housing of the coarse fuel filter and clean the filter.
- Check the rubber seal and replace if necessary.
- Smear the sealing rubber lightly with engine oil.
- Reassemble the filter and housing in the reverse sequence (torque 10 Nm).

Check the fuel system for leaks, with the engine running.

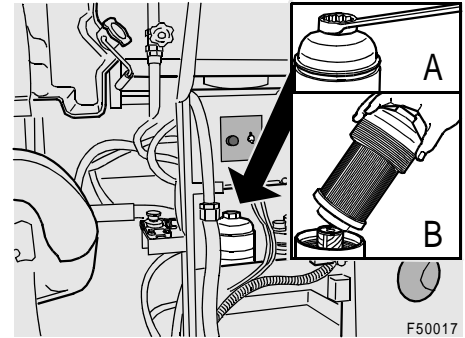

The fuel filter is located to the right of the engine next to the power steering reservoir.

Replace the filters by the following procedure:

- Remove the filter by rotating the filter housing cap to the left. Remove the filter element.
- Check the sealing rubber and replace if necessary.
- Smear the sealing ring sparingly with engine oil.

- Place a new filter element in the cap and attach the cap and filter element to the filter housing.
- Screw the cap on (torque 25 Nm).
- Bleed the fuel system.
- Check for leaks with the engine running.

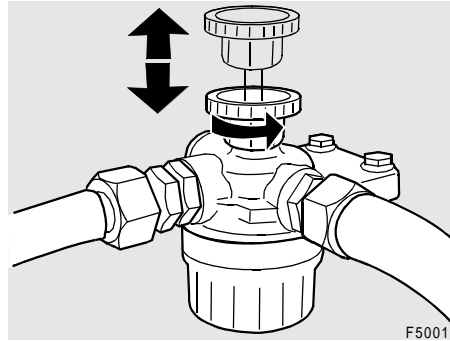

Bleeding fuel system.



Diesel fuel is flammable and should not be exposed to open flame or other heat sources such as a hot engine. Catch any leakage in a suitable container.

Rotate the bleed pump on the filter housing to the left so that the hand pump can be operated.

Pump, with the hand pump, until the filter housing is filled with fuel. Start the engine and lock the hand pump.

Starting after emptying the fuel tank.



Avoid emptying the fuel tank. The starting procedure described here is an emergency measure. The engine will only start after prolonged use of the starter motor. Failure to follow the instructions below may lead to damage to the starter motor.

- Bleed the fuel system.
- Operate the starter motor continuously until the engine starts. The maximum engagement period for the starter motor is one minute. If the engine fails to start in this time, allow the starter motor to cool for 2 minutes. Operate the starter motor again for 1 minute. Should the engine fail to start during this minute, allow the starter motor to cool for at least 30 minutes before the starting cycle above can be repeated.
- The engine will run unevenly for some time after starting.

ABS SYSTEM

Illumination of the red warning light at speeds above about 7 km/h indicates a fault in the ABS system.

Check the ABS system fuses.

If the fault is not cleared up by replacing fuses, the journey may continue since only the ABS system is inoperative and the normal braking function is preserved.



It is now possible that the wheels may lock on powerful braking.

Have the ABS system repaired by an authorised workshop.

EMERGENCY OPERATION OF THE FUTURAIR SYSTEM

If the display fails to function, the power supply is possibly disconnected.

First check fuses 36 and 37 (see fuse list).

Also check if the Futurair system master switch is in position 1 (auto).

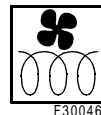

The Futurair system is provided with an automatic fault analysis function, which checks the operation of a number of components. If a fault is detected this is indicated by a flashing light on the display.

The meaning of these codes is explained in the FUTURAIR booklet supplied.

After checking the error codes, they can be removed from the display by simultaneously and briefly pressing the + and - buttons. If possible, the FUTURAIR system can select alternatives to allow the system to operate as well as possible despite the fault.

Emergency procedures

If a fault prevents the operation of the full system, the heating, and to a lesser extent the cooling, can be forced to operate. However the temperature will no longer be automatically controlled.

If interior heating is required, the switch Emergency operation of Futurair climate system page 43 must be in position 1 (emergency on). In this position the underfloor heater water valves are fully open and their fans are operated at 25%.

If it is too hot in the passenger area, the switch may be temporarily moved to position 0 (off).

When cooling of the interior is required, the roof fans may be switched to full power. The purple/white wire connector in the fuse box behind the dashboard should be removed for this purpose. The switch Emergency operation of Futurair climate system page 43 should then be in position 0 (off). Depending on the valve position at that time, internal or external air will then be blown into the interior. The roof heating water valve will then remain in the position it was in when the system failed.

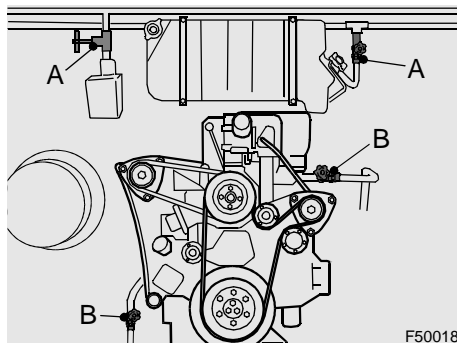

It may therefore happen that the valve is open and that hot air is blown in. If this is not desired, one of the closing mechanisms (A) may be closed by hand.



Remember to reopen the mechanism when the FUTURAIR system is repaired.



For troubleshooting, see the FUTURAIR booklet.

Heating system leaks

If leaks occur in the heating system, it is possible to isolate the system from the engine cooling system. The FUTURAS have one heating circuit supplying the roof units and one leading to the underfloor heaters. Should there be leaks in the roof units, this section may be isolated by closing both valves (A). Valves (B) should be closed in the case of leaks in the underfloor heaters.



If the vehicle can not be adequately heated, the water valves may be partly or completely closed: check the water valves and ensure that they are completely open.

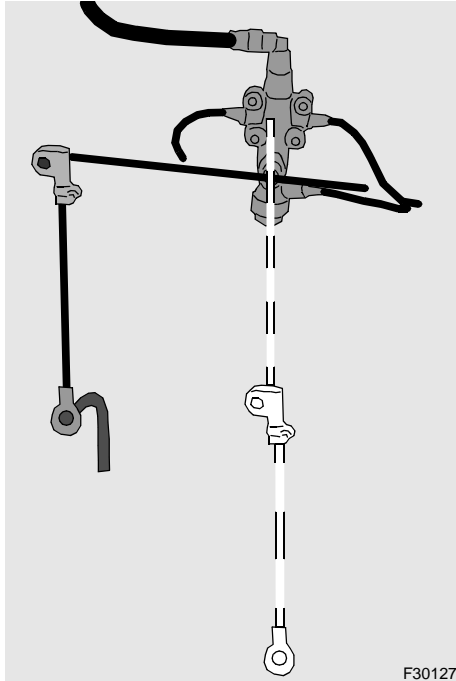

AIR SUSPENSION LEAKS

If a spring bellows develops a fault the remaining bellows on the same height regulation valve will also empty. Driving may continue at a reduced speed, as a rubber stop is fitted in the bellows.

The loss of air from the defective bellows must however be stopped as soon as possible. This can be done by disconnecting the control rod from the height control valve and allowing it to hang down. This interrupts the air supply to the bellows.

With the front axle, the control rod of both height regulator valves must be disconnected to prevent the vehicle tilting.



The journey may continue, at a reduced speed.

The fault must be repaired as soon as possible.

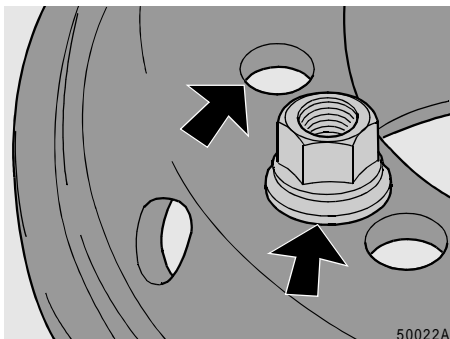

WHEELS AND TYRES

General

BOVA fit their coaches with the so-called wheel hub centering system. Characteristics of wheel hub centering:

- Wheels with cylindrical bolt apertures.
- Wheel nuts with loose, plain pressure rings which can not be removed.

 **Use only the appropriate wheel hub centering wheels and wheelnuts.**

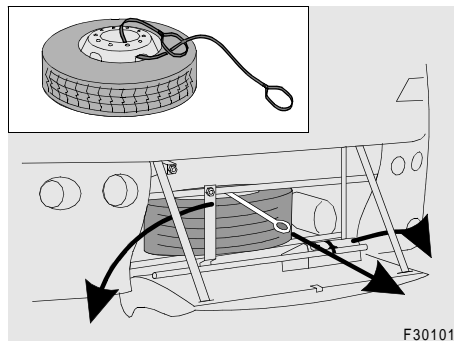

Spare wheel

The spare wheel is located behind the spoiler flap.

The spoiler flap is opened by pulling on the handle next to the steering column, see: Spoiler flap opening handle page 45.



Check first that the spare wheel is in a usable condition and inflate to the correct pressure, see: Tyre pressures page 113.

Remove the spare wheel by taking off the clamp and pulling a draw band through the wheel so that it can be pulled out.

Wheel replacement

- Park the vehicle on a hard, level road surface in a safe position.
- Chock the wheels to prevent the vehicle rolling.
- If necessary switch on the hazard warning lights and place the hazard warning triangle at least 30 m behind the vehicle.
- Clean the wheel nuts and apply a drop of oil to the thread.
- Loosen the wheel nuts one half turn.
- Place the jack next to the wheel in question (see: Jacking points page 93) and jack it up until the wheel is clear of the ground.



Read the documentation supplied before using the jack.

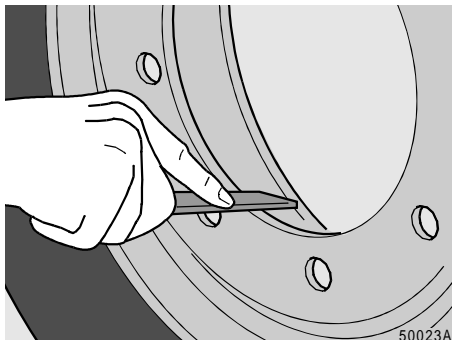

- Remove the wheel nuts and take off the wheel.
- Before fitting, clean the fitting face of the wheel hub and the inside of the spare wheel carefully, removing any burrs and paint residue. Lightly smear the fitting face with grease.

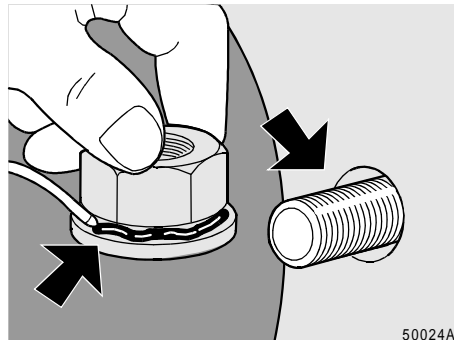

- Clean the wheel studs and apply oil to the threads.
- Apply a drop of oil between the pressure ring and the wheel nut.
- Offer up the wheel and turn the nuts up tight.
- Remove the jack and tighten the nuts sequentially and diagonally to the prescribed torque (650 Nm).



Retighten after 100 km.

Stow the spare wheel and the tools.
Don't forget the warning triangle.

Jacking points

Jacking points (circular plates) are provided and are located as follows:

- Behind the rear wheel, both left and right.
- In front of the front wheels, left and right.
- In the middle of the vehicle, to allow it to be lifted above a pit. These jacking points are located in the region of the end of the gear-box.

When only a single wheel needs to be replaced, it is sufficient to place the jack under the axle ends.

- For the front and trailing axle: under the wheel suspension casting.
- For the rear axle: under the axle mounting.

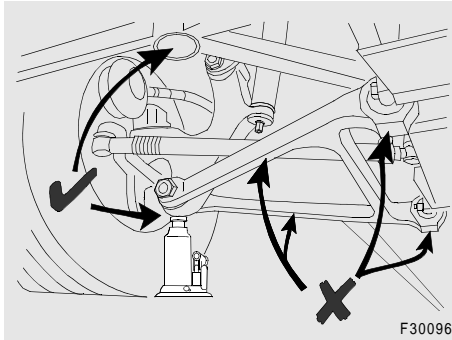

 **Never put a jack under the suspension triangle of the front axle or under the differential housing, or under the rear axle body itself.**

 **Always use stands when working under a jacked up vehicle.**

 **Read the documentation supplied before using the jack.**

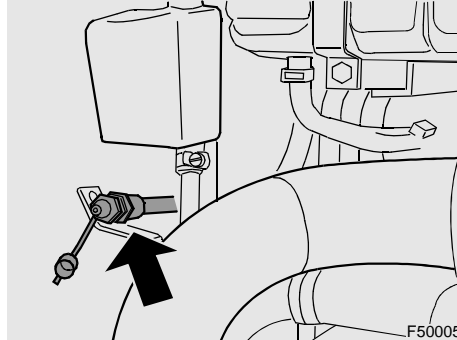

Emergency filling points

The BOVA Futura is provided with two emergency filling points. One is below the driver's seat behind the spoiler flap (A) and the other is in the engine compartment.

The whole compressed air system can be filled from outside via the emergency filling point in the engine compartment.

 **Ensure that the pressure in the system does not rise above 8.1 bar.**

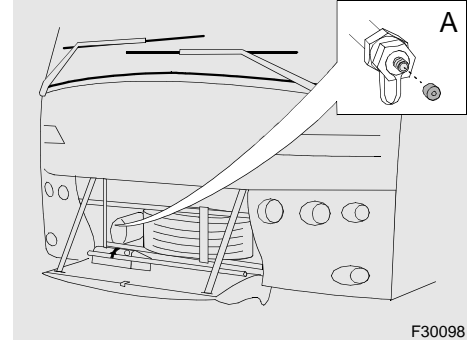

Filling point (A) is used exclusively to pressurise the the parking brake system. When the pressure in this system falls to around 5 bar, the parking brake can no longer be released with the handbrake lever.

Tyre inflation

Remove the cap from the emergency inflation connection.

Attach the inflation hose.

Inflate the tyres. The engine must be running but the stored pressure must not be at maximum, otherwise the compressor will not deliver air.



The pressure can be lowered by operating the brake pedal.

For correct tyre pressures see: Tyre pressures page 113.

REPLACING BULBS

General

Never touch the glass of bulbs with the fingers. Traces of grease, oil or other contaminants will adhere to the glass, shortening the life of the bulb. When the contaminants become damp they will attack the reflector.



Use the packaging to protect the glass from your fingers.



Check the headlight alignment whenever the headlamp bulbs are replaced.

For a complete list of the lamps and their specifications see: Lighting page 118.

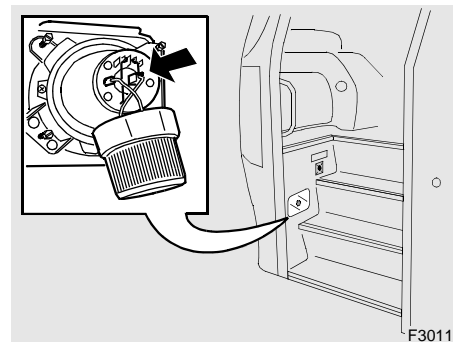

Headlamps, entryway side

Remove the covering hatch.
Remove the protective cover on the light by turning it to the left.
Pull out the light plug.
Unhook the spring.
Replace the bulb.



Make sure that the lamp engages in the recess in the reflector.

Headlights driver's side.

Open the side hatch below the driver's window. The headlamp bulbs can be replaced from this space.

Other lamps

Unscrew the plastic protective cover cap from the unit. Replace the bulb. Reverse the process to reassemble. With contour lights, the rear section of the unit should be given a quarter turn to the left, and removed. The bulb can now be withdrawn from the fitting. With some hatches this is possible from within the interior of the hatch. With the other hatches the unit must be unscrewed from the hatch.



Check the headlamp alignment whenever a bulb is replaced.

REPLACING FUSES

General

If an electrical component fails to operate this may be because a fuse has burned out due to temporary overload. The vehicle's fuses are in four locations.

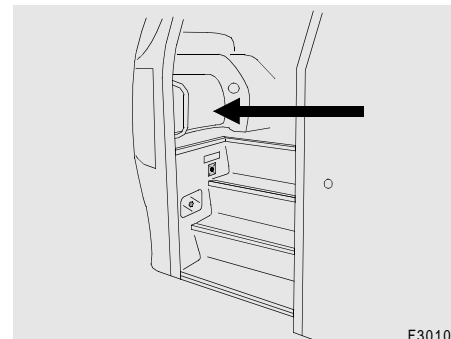

F30108

- One fuse box is by the front entry-way, under the dashboard. The fuse and relay summary lists for all four fuseboxes are located here.



See the fuse lists to find which fuse needs replacement.

- A second fusebox is located in the left sleeping or luggage compartment, in front of the rear axle. The electronics for the ABS/ASR/ Retarder hydraulics and the CAN extension box are also located here.
- A third fusebox is in the luggage space to the rear of the toilet. Most of the fuses for the toilet and kitchen are found here.
- A fourth panel is situated to the right hand side of the engine compartment in the electrical cabinet.

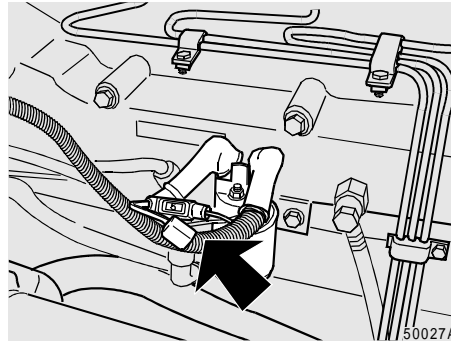

Pre-heater relay

The 5 amp fuse for the pre-heater warning lamp is near the pre-heater relay. The pre-heater relay is fixed to the inlet manifold on the right hand side of the engine.

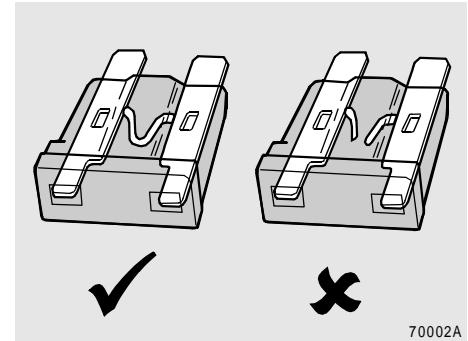

Pull the fuse straight out and look inside to see if the bent wire is burned out.

Replace if necessary with a new fuse of the same colour code and capacity. The amperage is stated on the fuse.



Never replace a blown fuse with one of a higher capacity.

If fuses in the same location burn out repeatedly, there is a failure in the electrical installation and the vehicle must be taken to a workshop for inspection.

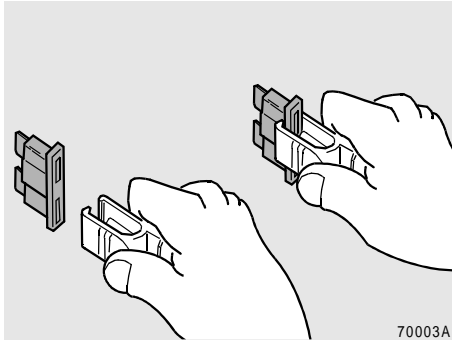

"Pincers" are provided for the easy changing of fuses.



Spare fuses are supplied with the tool-kit.



Don't forget to replace the pincers after use.

JUMP STARTING

If the vehicle is started with the aid of separate batteries (24V approx) or with the help of another vehicle with its engine running (28V approx) the battery cables must not be removed.



Never use quick starter equipment to start the vehicle as this may damage the vehicle electronics.



Avoid generating sparks as these may lead to the batteries exploding.



Prevent the two vehicles touching each other.

Attach the starter cable first to the positive (+) terminal clamp and then to the negative (-) clamp. When disconnecting, remove the cable from the negative (-) terminal first and then from the positive terminal (+). In the event that the batteries are completely discharged and the engine starts, it is important not to remove the starter cables immediately. To prevent damage to the electrical system through voltage peaks the engine must run for at least 3 minutes before the starter cables are removed.

TOWING



A vehicle with passengers inside must not be towed.

Safety

Always use a towing clevis, except in an emergency. Keep the speed to a maximum of 40 km/h in these circumstances.

Driving speed must always be matched to the conditions.



The drive shafts must always be uncoupled from the differential when towing over long distances to prevent damage to the gear box.

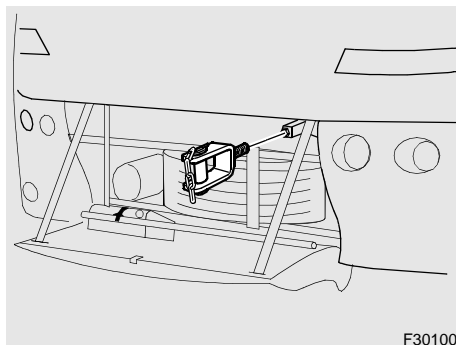

Fitting towing eye

A towing eye is supplied with each coach.

The towing eye is located behind the spoiler flap.

The towing eye may be screwed into a socket behind the spoiler flap, or behind a protective rubber in the rear bumper.



Screw the towing eye in as far as possible.

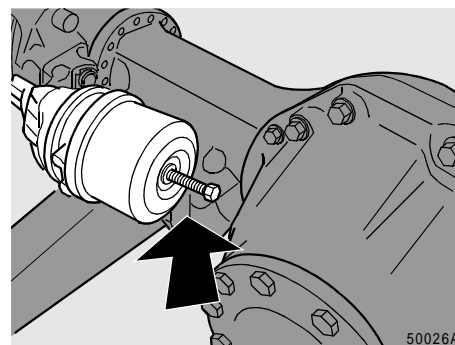

Releasing the parking brake

Start the engine and bring the brake system up to pressure.

If it is not possible to start the engine, the parking brake can be freed by two different methods.

- Place chocks in front of or behind the wheels and turn the bolts of both brake spring cylinders as far as possible to the left with the aid of a 24 mm spanner. The coach can now be towed.

Restore the operation of the brake spring cylinders as quickly as possible, by turning the bolts as far as possible to the right setting them with a torque of 40-50 Nm.

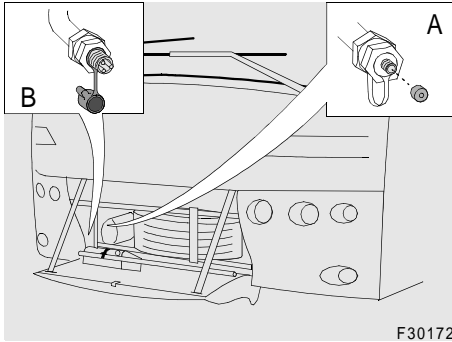

F30172

- The second method of freeing the parking brake makes use of the emergency air connection (A), to which an air hose can be connected to import air from the reservoir (B) or an external source.

! To free the parking brake the system must be pressurised to at least 5 bar.

! Maximum pressure in the parking brake may not exceed 8.1 bar.

If the engine is not running the vehicle's steering will be heavy due to the lack of power steering.

! Turn on hazard warning lights before towing and attach an "on tow" sign to the towed vehicle.

Towing with a damaged differential

Hoist the rear of the coach and lock the steering wheel.

Towing

! Vehicles with automatic transmission can not be towed.

If the vehicle must be towed to start the engine, the ignition key must be turned to position I.

When towing it may happen that the batteries are too low to allow the master switch to be closed by the dashboard switch.

To prevent damage to the dynamos and regulator, master switch relay contacts 31 and 31a must be temporarily connected together (see drawing).

The master switch relay is located in the luggage space to the left, just behind the front axle.

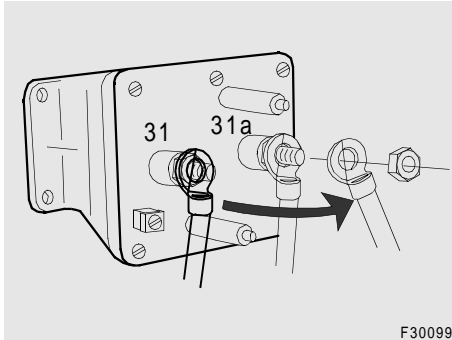

- Remove the battery earth clamp.
- Connect together the master switch relay cables with a bolt.
- Reconnect the battery earth clamp.

The vehicle may now be towed to start the engine.

After the engine has run for a time and the batteries are sufficiently charged the master switch relay must be reconnected in the original configuration.

Proceed as follows:

- Switch off the engine.
- Disconnect the battery earth clamp.
- Restore master switch relay connections.
- Reconnect battery earth clamp.

Towing other vehicles

The vehicle to be towed may not be heavier than 25 tonnes.

ITS BOVA

ITS BOVA deal with emergencies and strandings, free, 24 hours per day, 365 days per year.

ITS BOVA can be contacted on



+31 (0)40 2948080

The international code for the Netherlands is 00-31 from most EC countries.

NB:

This applies to countries outside the Netherlands: a BOVA coach which is stranded in the Netherlands must be repaired by an affiliated DAF dealer.

To use the ITS service you need the following information:

This information is on the identification papers, the ID card supplied with the coach and on the identification plate in the entrance to the vehicle. Make sure you have this information with you when phoning:

- Vehicle type
- Year of construction
- Vehicle owner
- Chassis number
- Registration number
- Name of the workshop where the vehicle is serviced (home dealer).
- Exact location of the vehicle (ask someone who is familiar with the area).
- Telephone number where you can be reached.
- Suspected cause of the breakdown.
- Proof of guarantee
- ID card, to help identify the correct spares

If the home dealer is offering a payment guarantee for a repair, the invoice from the repairing dealer goes to the owner through the home dealer. This also applies to any BOVA spares supplied.

In this way the driver does not have to pay for any repairs and he can express in his own language what the cause of the breakdown is.

Once a driver has contacted ITS for assistance, he must not leave the place mentioned without first reporting this to ITS.

BOVA service and spares delivery

In the Netherlands:

On working days from 8.00 to 17.00



+31 (0)40-2084611

In a number of countries the DAF dealer can supply both BOVA and DAF parts from stock.

6 IDENTIFICATION

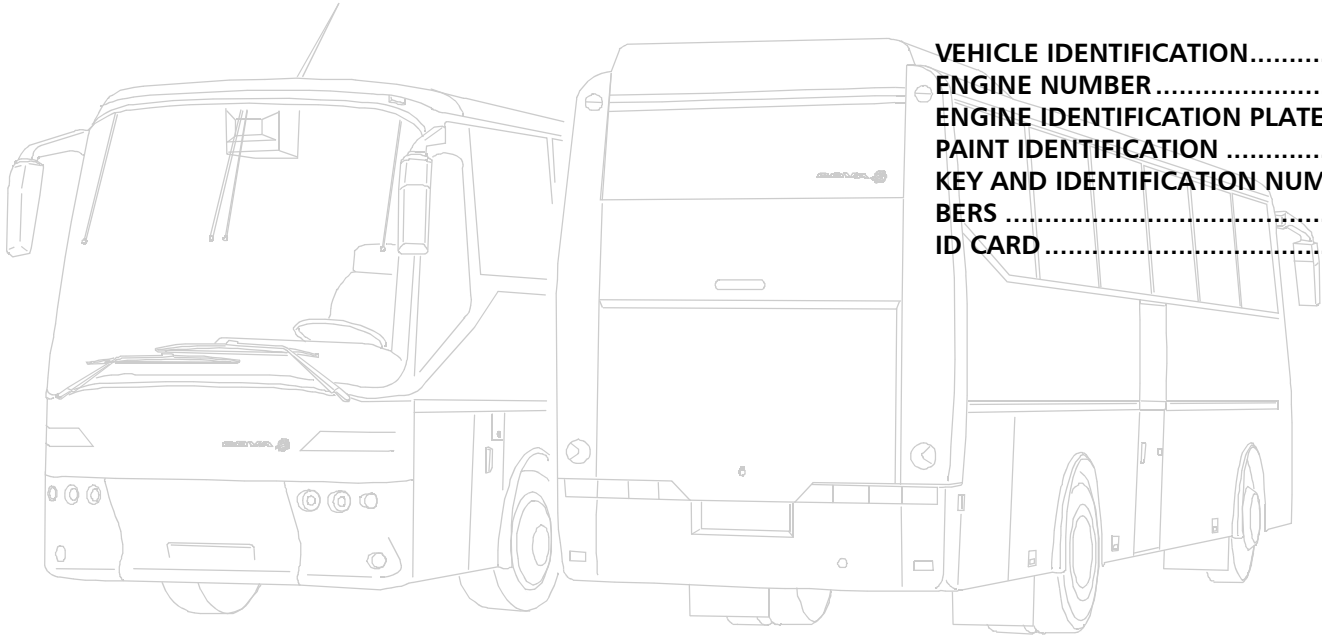

- VEHICLE IDENTIFICATION..... 106
- ENGINE NUMBER 108
- ENGINE IDENTIFICATION PLATE 108
- PAINT IDENTIFICATION 108
- KEY AND IDENTIFICATION NUM-
BERS 109
- ID CARD 110

Futura

VEHICLE IDENTIFICATION

The identification plate is located at the entrance to the front of the vehicle.

A	Approval number
B	Chassis number
C	Maximum permitted axle loads in the country for which the vehicle was produced (see country code)
D	Maximum permitted combined axle loads (usually EC)
E	Maximum technically permissible axle loads (all countries)
F	Country code
G	Type
H	Engine number
J	Length of coach
K	Width of coach
L	Combination length
M	Year
N	Various
P	Absorbption figure
Q	Spare

AUTOBUSFABRIEK BOVA B.V.			
A			
B			
VIN	C	D	E
	C0	D0	E0
1	C1	D1	E1
2	C2	D2	E2
3	C3	D3	E3
4			
			kg
			kg
			kg
			kg
	L	J	cm
	W	K	cm
		L	cm
M			
N			
P			
Q			
			plant code
			F
			type
			G
			engine no
			H

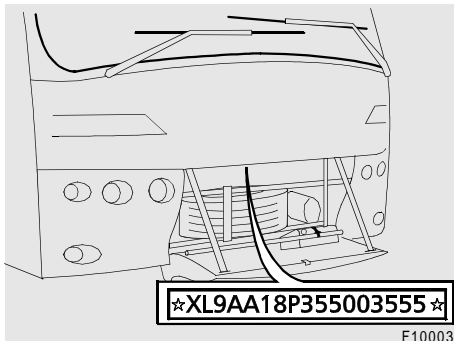

Chassis number

The chassis number is made up according to the international V.I.N. standard (Vehicle Identification Number).

The last 8 figures of the chassis number form the BOVA chassis number. Always mention these 8 figures when communicating about the vehicle, e.g when ordering parts. For the use of regulatory authorities the chassis number is also stamped into the chassis beam above the spoiler flap which allows access to the spare wheel.

Example: XL9AA18P355003555

XL9	Company identity
A	Engine at rear
A	4 x 2 (two axles, one driven)
18	Body type
P	Engine: DAF
3	Model year
55555	Serial number
003	WMI-code

Axle loads

The maximum axle loads as stated in sections C, D and E are distributed as follows:

Blank	Total weight
0	Train weight (including trailer)
1	Axle load, front axle
2	Axle load, rear axle
3	Axle load, trailing axle
4	Spare

Country code

Stated here is the country the vehicle was produced for. The country codes of the Dutch approval body RDW are found here.

Type indication

Example: FHD12-340XE

FHD	High version
12	Coach length in metres
340	Engine capacity (hp)
XE	DAF

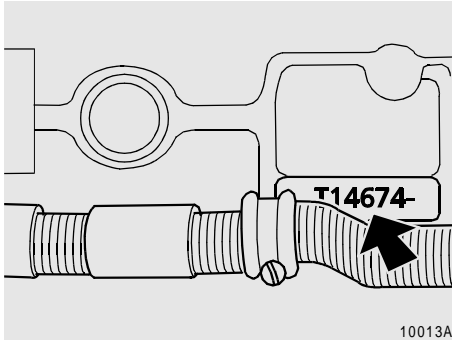

ENGINE NUMBER

The engine number is stamped into the engine block above the starter motor.

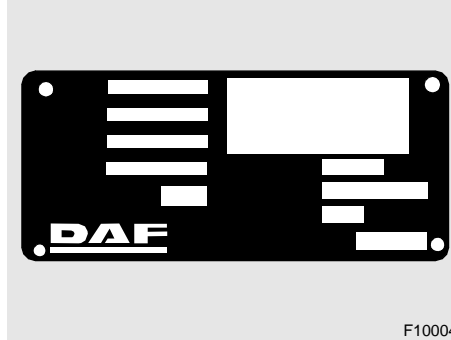

ENGINE IDENTIFICATION PLATE

The engine identification plate is on the inlet manifold. The engine type, engine number and certain adjustment data are stated.

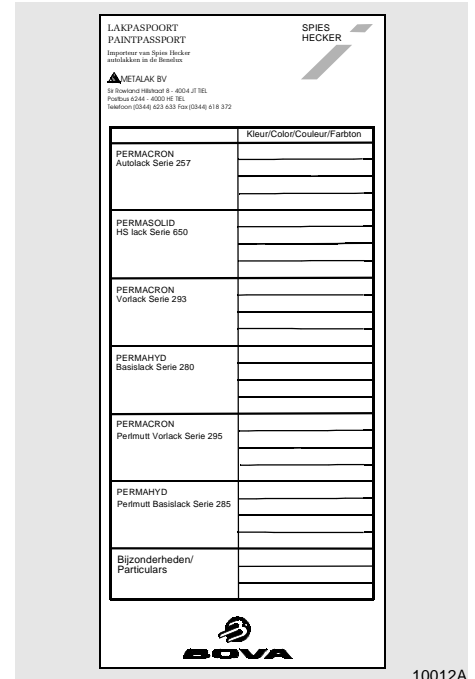

PAINT IDENTIFICATION

The paint identification and paint supplier are indicated on a sticker on the inside of the fusebox cover in the

dashboard.

The most important information on this sticker is the international RAL numbers which enable paint of exactly the same colour to be ordered from any local paint supplier.

If possible BOVA always uses a RAL colour, unless the owner wants his own (company) colour. In these cases a code is mentioned which denotes the composition of that particular colour which remains available from BOVA.

To avoid mistakes when ordering paint it is advisable always to include the chassis number along with the RAL numbers.

KEY AND IDENTIFICATION NUMBERS

A number of keys are supplied with each vehicle. When replacing, e.g. one boot lid lock, it is not possible to order a new lock with the same lock number as the rest. Keys with a specific serial number can however be supplied afterwards.



We strongly advise you to note the numbers of the keys.



Identification numbers for the various items of equipment fitted to the coach can also be reported here.

	Key and identification number:
Ignition key	
Dashboard box	
Driver's box	
Passenger door	
Central door	
Emergency door	
Luggage flap	
Bonnet	
Filler cap	
Safe	
Toilet	
Toilet locker	
Refrigerator	
TV	
Video	
Radio	
CD player	
Navigation system	
Alarm system	

ID CARD

All important components of your vehicle and their identification numbers are listed on this card.



If you are stranded and contact ITS BOVA you must have this card with you.

7 TECHNICAL DATA

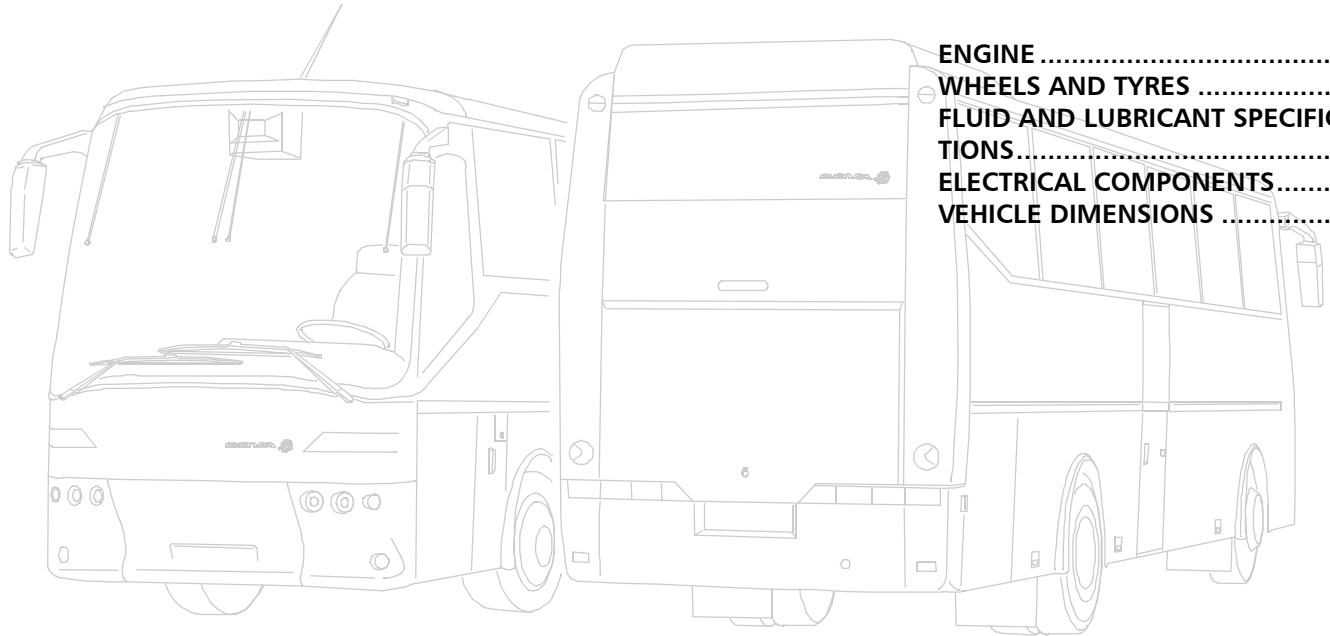

ENGINE	113
WHEELS AND TYRES	113
FLUID AND LUBRICANT SPECIFICATIONS.....	114
ELECTRICAL COMPONENTS.....	118
VEHICLE DIMENSIONS	120

Futura

ENGINE

Make	DAF		
Type	XE 250 C1	XE 280 C1	XE 315 C1
Location	Vertical, behind rear axle		
Engine configuration	4 stroke diesel engine, direct injection, 6 cylinders in line, turbo and intercooler		
Number of valves	24		
bore x stroke	130 x 158		
Capacity	12.58 litres		
Compression ratio	17.4 :1		
Engine capacity	250 kW (340 hp) at 1900 rpm	280 kW (380 hp) at 1900 rpm	315 kW (430 hp) at 1900 rpm
Maximum unloaded engine speed	2270 ±30 rpm	2270 ±30 rpm	2270 ±30 rpm
Maximum engine speed loaded	1900 rpm		
Maximum torque	1600 Nm between 1000-1450 rpm	1750 Nm between 1000-1500 rpm	1900 Nm between 1000-1500 rpm
Speed limiter	via UPEC engine management		
Emissions	Euro 3		

WHEELS AND TYRES

Tyre pressures

The tyre pressures given here are those appropriate to the stated tyre sizes when the vehicle is used under normal conditions. For all other cases see the tyre manufacturer's table.

Tyre size	Pressure (bar)	
	Front	Rear
295/80 R 22.5	8.0	7,7

Torque

The wheel nut torque is 650 Nm



Retighten wheelnuts after 100 km.

Winter tyres

The maximum speed specified by the manufacturer must not be exceeded.

Where winter tyres are used we recommend that the tyre manufacturer's guidance is followed regarding the fitting and the tyre pressures.

Snow chains

The driver of a vehicle fitted with snow chains may have to comply with legal requirements such as traffic sign 68.

This makes the use of snow chains compulsory when the road surface is icy or under snow.



The chains must consist of small links which do not protrude, so as to avoid them scraping on the suspension and other parts.

 **Speeds above 50 km/h are not permitted when snow chains are in use.**

Avoid driving with snow chains fitted where there is no snow, as this causes highly accelerated wear to tyres and chains.

FLUID AND LUBRICANT SPECIFICATIONS

General

In this section the lubricants and fluids are specified which must be used in maintaining the BOVA Futura. Your supplier of these lubricants can advise you on which products meet the specifications described.

The information provided in this section applies for normal driving conditions and the quantities are approximate. In extreme conditions (e.g. outside temperatures below -20 °C or above +40 °C advice must be requested from BOVA service or the manufacturer of the part in question.

 **Avoid skin contact with fuels, lubricants and coolants.**

Engine

Type	DAF XE250C1/XE280C1/XE315C1
Lubrication oil specification	15W-40 / ACEA-E3
Contents incl. filters and oil cooler	39.5 litre

Cooling system

Coolant specification	ASTM D 3306, BS 6580 and SAE-J-1034
Cooling/heating system capacities	between 65 and 100 litres, depending on the model.

As standard the cooling system of the BOVA Futura is filled with "DAF Coolant -37". This is a mono ethylene glycol based ready to use coolant with anti-corrosion additives in demineralised water. Frost protection is guaranteed down to -37° C.



Coolant medium is toxic. Protect skin and eyes. Coolant medium is damaging to the environment, and must therefore be treated as industrial waste.



Never fill with propylene glycol, since ethylene and propylene glycol are incompatible.

Gearbox

Type	ZF-6S 1600	ZF-8S 180	ZF 5HP600
Lubricant specification	SAE 30 API CD/CE/CF/SF/SG		ATF
Capacity when refilling	± 14 litres	± 12 litres	± 15 litres
Number of gears	6	8	5

Shift operation

Type	HGS	Automatic
Operation	Hydro-pneumatic	Electro-pneumatic
Fluid specification	Brake fluid DOT4	-

Clutch

Type	Single dry plate
Diameter	430 mm
Operation	Hydraulic
Fluid specification	Brake fluid Dot 4

Rear axle

Type	ZF A-131
Lubricant specification	SAE 80W-90, SAE 85W-90, SAE90 / API GL-5
Axle bridge capacity	20 litres approx.

Front and trailing axles

Type	ZF RL 85 E
Lubricant specification Hub	Lithium soap grease (NLGI class 2, type KP2K-30 grease to DIN 51825)
Grease specification Grease nipples	Lithium soap grease (Extreme pressure multipur- pose grease)

Steering gear

Type	ZF 8098
Fluid specification	ATF Type DEXRON-IID or ATF MERCON-M
Capacity	10 litres approx.

Hydraulic drive

Drive of the fan	
Fluid specification	ATF type DEXRON 3 on min- eral base
Capacity	12 litres approx.

Fuel

Diesel fuel must comply with specification EN 590. In extremely low temperatures a maximum of 20% kerosine may be added.

Where this is not permitted by law, a maximum of 20% lead free petrol may be added.



Where diesel fuel with a sulphur content greater than 0.2% is used, the engine oil change interval should be shortened to a maximum of 25,000 km.

Fuel should satisfy the following lubricity standard:

Test method: HFRR according to norm CEC-F-06-A96

Test value: $\leq 460 \mu\text{m}$

Fuel tank capacity

	Left tank	Right tank
FH 10	250 L	-
FH 10 RHD	-	250 L
FH 12-13-14-15	380 L	-
FH 12 RHD		365 L
FL	290 L	-
FL RHD		270 L

ELECTRICAL COMPONENTS

Starter motor

Type Bosch JE
Output 6.2 Kw

Dynamos

Type Alternating current
Output 24 V x 100 A

Batteries

Number 2
Voltage 12 V
Capacity 230 Ah

Wash/wipe system

Wiper blade dimension 100 cm
Reservoir capacity 8 litres

Towing hook junction box

D+ connection maximum 2 A
Constant supply Maximum 7.5 A

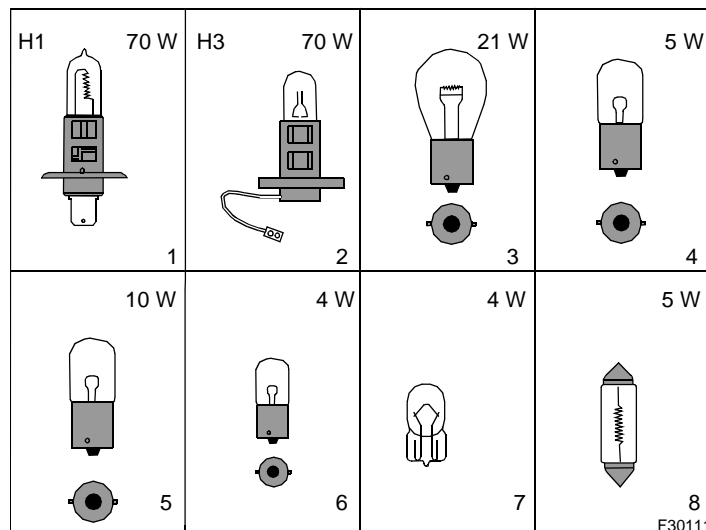

Lighting

		Number	Type	Capacity
A	Headlamps (H1)	2	1	70 W
B	Main beam (H1)	2	1	70 W
C	Foglamps (H3)	2	2	70 W
D	Parking light (front)	2	*	5 W
E	Front indicator lamp	2	3	21 W
F	Side indicator lamp	2	3	21 W
G	Rear indicator lamp	2	3	21 W
H	Rear lamp	2	4	5 W
I	Brake light	2	3	21 W
J	Rear fog lamp	1	3	21 W
K	Reversing lamp	4	5	10 W
L	Third brake light	1	LED	--
M	Side profile lamps		7	4 W
N	Top lighting	4	8	5 W
O	Registration plate lighting	2	8	5 W
	Luggage space lighting		8	5 W
	Engine compartment lighting		8	5 W

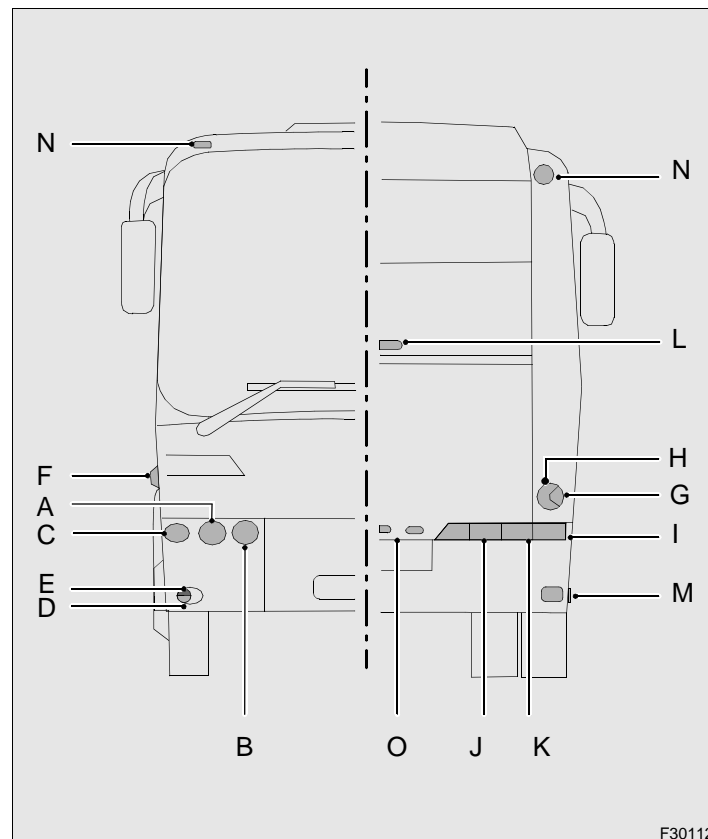

F30112

VEHICLE DIMENSIONS

Specified weights and dimensions are given in the following table. The actual weights (in particular) of the vehicles can vary from these specifications depending on the options installed. Before delivery the vehicles are weighed and a copy of the weight registration form stating the actual empty weight is added to the delivery documents. Weights are expressed in kilograms and dimensions in millimetres.

	FH 10	FL 12	FH 12	FL 13	FH 13	FH 14	FL 15	FH 15
A	10.405	11.990	11.990	12.700	12.700	13.580	14.990	14.990
B	2.490	2.490	2.490	2.490	2.490	2.490	2.490	2.490
C	3.551	3.334	3.551	3.330	3.545	3.561	3.321	3.561
D	4.885	6.090	6.090	6.800	6.800	6.090	6.800	6.800
E	2.460	2.700	2.700	2.700	2.700	2.700	3.400	3.400
F	3.060	3.200	3.200	3.200	3.200	3.200	3.200	3.200
G	-	-	-	-	-	1.590	1.590	1.590
Unladen weight	11.500	11.600	12.400	11.850	12.650	15.100	14.950	15.450
Maximum laden weight	18.000	18.000	18.000	18.000	18.000	24.450	24.450	24.500
Turning circle	18.500	22.000	22.000	23.600	23.600	22.000	24.400	24.400

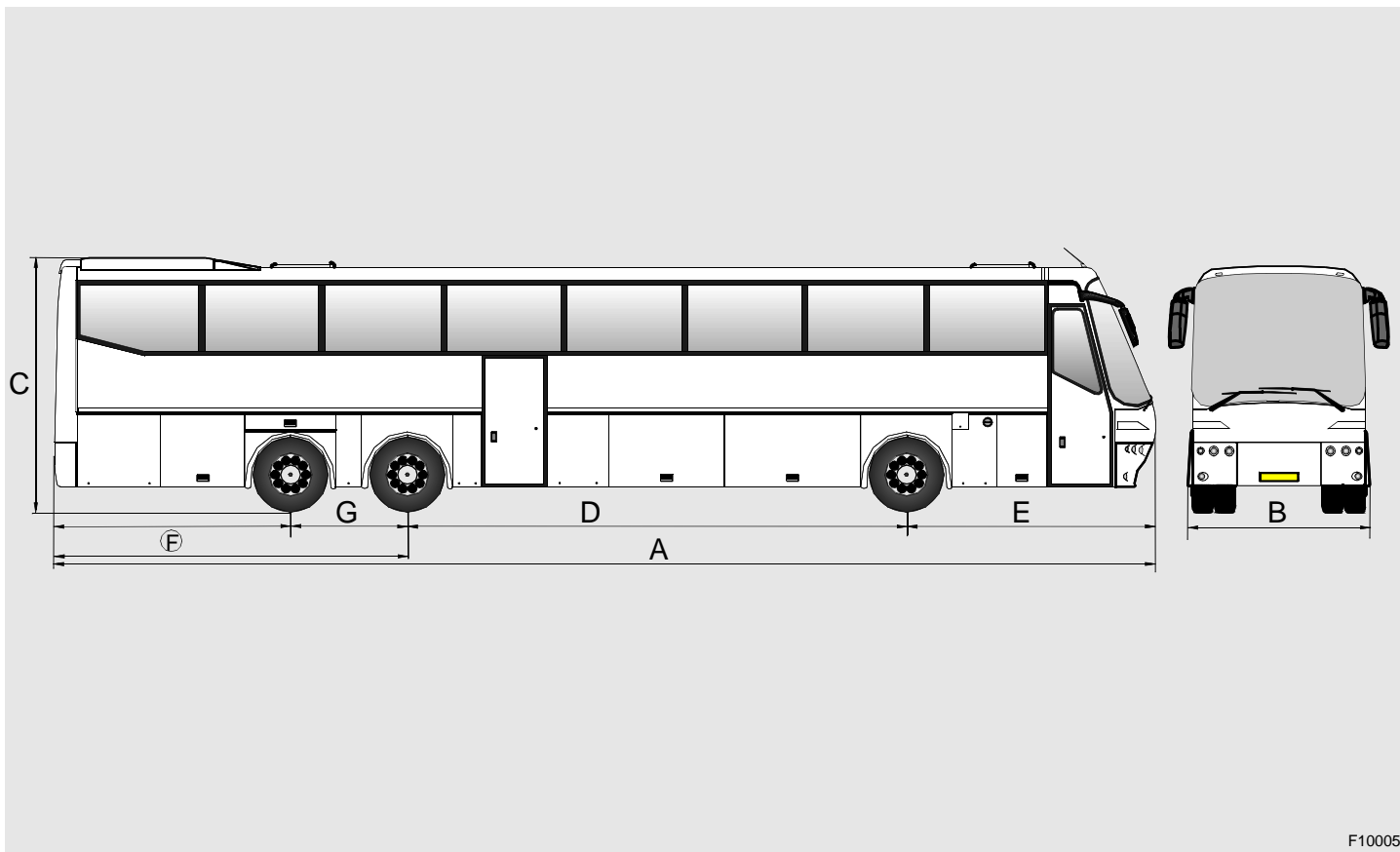

8 SUBJECT INDEX



Futura

A			
ABS system	89	Combi-switch	18
Adjusting v-belt tension	86	Coolant level	69
Air filter	70	Cruise control	32
Air leaks	7, 11	D	
Air pressure gauge, circuits 1 and 2 ..	17	Dipped beam/Main beam/Indicators	18
Air suspension leaks	91	Direction indicators	18
Air-conditioning system	11	Driver's and guide's ventilation fan ...	48
Ashtray	36	Driver's compartment air conditioning	49
B		Driver's illumination	30
Batteries	6, 73	Driver's seat	51
-Charging	6	E	
Bleeding fuel system	88	Electrically heated driver's sliding window	42
Brake pedal	44	Electrically operated driver's side window	42
Brake system air dryer	71	Emergency filling points	94
Braking	10	Emergency hammers	60
Bremsomat	31	Emergency operation	
C		-Passenger and central door	58
Central greasing	73	Emergency procedures	60
Chassis number	107	Engine brake	44
Cigar lighter	38	Engine identification plate	108
Climate system futurair	34, 41	Engine number	108
-Emergency operation	43, 89	Engine oil level	68
Clutch	9	Engine stop lever	11
Clutch fluid	72		
		F	
		Film cabinet lighting	48
		Fire extinguisher	58
		First aid kit	59
		Fluid and lubricant specifications	114
		Front box dust filter	72
		Front door operation	38
		Front heater	43
		Fuses	
		-Pre-heater warning lamp	97
		G	
		General hints	8
		H	
		Hazard warning lights	60
		Hazard warning triangle	60
		Hydraulic fluid	70
		Hydraulic Gearshift fluid	71

I		M		P
ID card	110	Maintenance		Paint identification
Identification numbers	109	-Daily checks	68	Parking brake
Ignition key mechanism	45	-Exterior	76	Passenger seats
Individual reading lamps	30	-For winter	74	Personal setting units
Inspection and maintenance		-Interior	78	Power steering fluid
-Checklist	66	-Weekly checks	69	
Inspection lamp plug	85	-When winter is over	76	R
ITS BOVA	102	Mobile telephones	6	Raising/kneeling
		Multi-V belt	86	Releasing the parking brake
J				Replacing bulbs
Jacking points	93	N		Replacing fuel filter
Jump starting	98	Navigation system	36	Replacing fuses
		Night illumination	31	Replacing v-belts
K				Retarder
Kitchen equipment	48	O		-operating handle
		On-board tool kit	84	Roof hatches
L		Original BOVA parts	7	Roof unit dust filters
Light switch	30			Running in
Luggage	5			
Luggage compartment unlocking	49			

S		T	
Safety belts	59	Tachograph	24
Safety requirements	5	Top lights	48
School bus version flashing lights	49	Touching up paintwork	78
Screenwash reservoir	71	Towing	99
Service and spares delivery	102	Towing eye	84, 99
Service documentation reply form	129	Towing hook junction box	118
Snow chains	114	Transformer	49
Spare wheel	92	Transmitters	6
Speed limiting device	11	Trunk compartment lighting	49
Spoiler flap opening handle	45	Tyre inflation	95
Starting procedure	9	Tyre pressures	113
Stopping/Parking	10	V	
Switching off engine	11	Vehicle dimensions	120
System voltage	6	Vehicle identification	106

W	
Warning lights	38
Warning symbols	5
Warning triangle	5
Warranty conditions	7
Water system	74
Welding	5
Wheel nuts	9
Wheels and tyres	92, 113
Windscreen washers	18
Windscreen wipers	18
Winter conditions	5
Winter tyres	113

BOVA SERVICE DOCUMENTATION REPLY FORM

If you have any suggestions and/or comments concerning this manual or if you find any faults, please fill out this form and send it to:

Autobusfabriek BOVA b.v. afdeling Service documentatie Postbus 5 5550 AA Valkenswaard Fax: +31 (0)40 2019477		Company name :		
		Name :		
		Signature :		
Chassis number			
Concerning Document ordernumber:		Version:		
Type of document: (mark what is applicable)	Drivers manual	<input type="checkbox"/>	Futurair manual	<input type="checkbox"/>
	Maintenance manual	<input type="checkbox"/>	Electrical diagrams	<input type="checkbox"/>
	Workshop manual	<input type="checkbox"/>	Training manual	<input type="checkbox"/>
	Parts catalogue	<input type="checkbox"/>	Others	<input type="checkbox"/>
Kind of inaccuracy (mark what is applicable)	Linguistic (Definition) not correct	<input type="checkbox"/>	Mistake in technical data (values)	<input type="checkbox"/>
				Illustrations
				<input type="checkbox"/>
Explanation			

BOVA will take your report seriously and, if necessary, we directly make an update in the document.

